

FIM5360



NITGEN® FIM5360

Stand-Alone Fingerprint Identification Device with Built-in CPU

Datasheet

Supported Firmware Version: 1.11 or above

Version 1.04

© Copyright 2011 NITGEN Co., Ltd.

ALL RIGHTS RESERVED

Serial Number:

Specifications can be changed without notice.

Revision History

<i>Date of Revision</i>	<i>Version</i>	<i>Description</i>
2010.11		release
2011.01	1.01	'GPIO function' is added 'SI_MAX_TEMPLATE' is added 'Recommended circuit to use GPIOs' is added 'Naming Rule' is added 'Support Information' is renewed 'Block Diagram' is renewed
2011.02	1.02	Current Consumption specification is renewed
2011.03	1.03	IO function is renewed
2011.04	1.04	Latent Option is added

Table of Contents

1. GENERAL DESCRIPTIONS6

2. TARGET APPLICATION7

3. SPECIFICATION8

 3.1. BASIC FEATURE8

 3.2. SENSOR FEATURE9

 3.3. INTERFACE FEATURE10

4. BLOCK DIAGRAM11

5. OPERATION12

Reset12

Communication12

Custom Data Area12

IO Function12

Board configuration option13

6. TECHNICAL DATA15

 6.1. PHYSICAL CHARACTERISTICS15

The Feature of Board15

The feature of fingerprint sensor16

The feature of sensor Cable17

 6.2. EXTERNAL PORT18

 6.3. CONNECTOR20

Sensor20

<i>Communication</i>	20
6.4. ELECTRICAL CHARACTERISTICS	21
7. ORDERING INFORMATION	22
7.1. FIM5360 ORDERING GUIDE	22
7.2. NAMING RULE	23
APPENDIX	24
RECOMMENDED CIRCUIT TO USE GPIOS.....	24
BOOT UP TIME	26
SUPPORT INFORMATION	27

1. General Descriptions

Biometric systems are recently used in various authentication systems. They are increasingly used not only in environments that require high level of security but also in many other places because they are convenient and economical. Among various biometric systems, the fingerprint recognition system takes up most of the market because it is easy to use as well as economical and capable of developing various types of applications. NITGEN, a global leader in the fingerprint recognition industry, provides various fingerprint authentication solutions such as PC security, knowledge management, vaulting service, access control, electronic approval, and financial payment. NITGEN actively responds to customer needs through continuous research, development and quality management.

FIM5360 is a stand-alone Fingerprint Identification Device with many excellent features. It provides benefits such as high identification performance, low power consumption and UART serial interfaces with the various commands for easy integration into a wide range of applications. It is a durable and compact device with fingerprint identification module containing NITGEN® optics-based fingerprint sensor inside.

- 1 ID multi-Templates mode
- Up to 2,000 Templates
- More than 30,000 logs
- Using New sensor OPP06
- Changeable user's verification security level
- Selectable UART communication Level (RS232 or LVCMOS)
- Selectable rotation angle range (+/- 45 ° or +/- 180 °)
- Support Auto-Identify mode

- Support ISO197974-2 and ANSI 378 format
- Support Device Master password
- Provide custom data area
- Compatible template format with NITGEN eNBio API
- Support GPIO control

2. Target Application

Access Controller
Time and attendance management
Security application
Safety Box
ATM, POS and more

3. Specification

3.1. Basic Feature

Hardware Specification

ITEM		FIM5360
Board Spec.	CPU	S3C2410 (ARM9 266Mhz)
	DRAM	16MByte SDRAM
	Flash ROM	8MByte
Dimension		43 x 60 [mm ²]
Sensor		NITGEN OPP06
Supply Voltage		5 / 3.3 [V]
Current	Normal	70 [mA]
Consumption	Max	220 [mA]
Operating Temperature		-20 ~ 60 [°C]
Humidity		~ 90 [% RH]
ESD Tolerance		±8 [KV] (indirect)
Communication Channel		RS-232 level UART Speed: 9600 ~ 115200 [bps] (1 start bit, 8 data bit, no parity, 1 stop bit)
Maximum Template Storage		Up to 2,000 templates
Maximum Log Storage		Up to 30,705 Logs

Operation Specification

ITEM	FIM5360
Capture Speed	0.2 [sec]
Verification Speed	Less than 1 [sec]
Boot Up Time	0.4 [sec] for 100 templates 0.5 [sec] for 1,000 templates 0.7 [sec] for 2,000 templates
Data Encryption Method	AES for saving data AES for DB communication

Boot-up time is explained in Appendix.

3.2. Sensor Feature

OPP-06

Sensor Name	OPP-06
Sensing Type	Optical
Sensing Area	15.0mm x 18.5mm
Image Resolution	500 DPI
Image Size	260 x 300

3.3. Interface Feature

Interface

RS232 Level UART	RS-232C Up to 115200bps Baud Rates supported (Default : 9600bps)
I/O	Sensor LED control, 2 relay output

4. Block Diagram

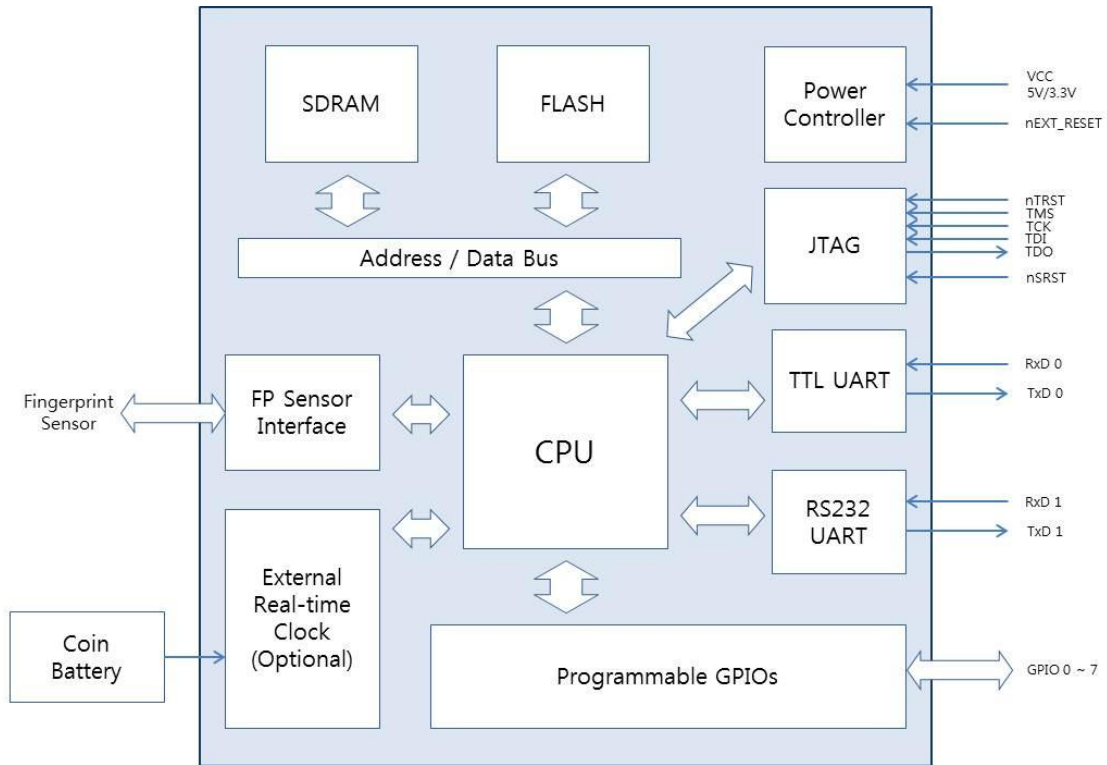

RS-232C communication data consist of 8-bit data, no parity, 1-bit start-bit and 1-bit stop-bit.

5. Operation

Reset

FIM5360 provides external low-active reset signal port. By setting the reset port low state, FIM5360 could be initialized. The reset port is internally pull-uped to VCC.

Communication

FIM5360 has RS232C UART serial communication port. This port support 6 baudrate modes such as 9600, 14400, 19200, 38400, 57600, and 115200 bps.

FIM5360 follows NITGEN Serial Communication protocol. For more detail information refer to the document "FIM ComProtocol.pdf".

UART data consists of 1 start bit, 8 data bit, no parity bit and 1 stop bit.

Custom Data Area

FIM5360 provides 64 Kbytes flash memory. Using this memory, host can save private data for specific usage. The caution is needed for the responsibility for reading, writing and erasing because user data area is given to the host.

IO Function

IO configuration depends on emulation mode

Emulation mode	Description	Configurable
OFF	5 Programmable GPIOs	Yes
FIM20 mode	GPIO0, 1 are only available as Relay Output	No
FIM30 mode (default)	2 Result Outputs + 3 Key functions	No

Default emulation mode is FIM30 emulation mode.

IO functionality of FIM30 mode

IO	Description
GPIO0	Output high when authentication, registration and deletion are succeeded.
GPIO1	Output high when authentication, registration and deletion are failed.
GPIO2	Do registration when the port level goes from high to low.
GPIO3	Do deletion when the port level goes from high to low.
GPIO4	Do identification when the port level goes from high to low.

Please refer Appendix F of ComProtocol document to get more information about Programmable GPIOs.

Board configuration option

The following table shows board configuration system option. Using NITGEN Serial Communication protocol, these option values can be changed.

Code	System Information	Value Range	Default Value	
0x02	SI_USING_LOG	True/False	False	
0x17	SI_IDENTIFY_TIMEOUT	255 or 10~250	30	100ms tick
0x18	SI_RELAY_TIME	0 or 1~100	10	100ms ticks
0x19	SI_CAPTURE_TIMEOUT	More than 10	50	100ms ticks
0x20	SI_IMAGE_BRIGHTNESS	0~100	45	100 - brightest
0x21	SI_IMAGE_GAIN	1,2,4,8	2	
0x22	SI_IMAGE_CONTRAST	0~100	20	
0x28	SI_ADAPTIVE_CAPTURE	True/False	False	
0x30	SI_VERIFY_SECURITY_LEVEL	1~9	5	
0x31	SI_IDENTIFY_SECURITY_LEVEL	6~9	8	

0x32	SI_REGISTER_QUALITY	30~100	40	
0x33	SI_VERIFY_QUALITY	10~100	30	
0x38	SI_USING_LATENT	True/False	False	
0x49	SI_CHANNEL1_BAUDRATE	0 – 115200 1 – 57600 2 – 38400 3 – 19200 4 – 9600	4	
0x4A	SI_CURR_CHANNEL_BAUDRATE			
0x50	SI_MAX_USER			
0x51	SI_FP_FULL_ROTATION	True/False	False	
0x52	SI_LENGTH_OF_USER_ID	4~15	10	
0x53	SI_NUM_OF_ADAPTIVA_CAP	1~10	5	
0x54	SI_MAX_TEMPLATE			Read Only

1) True means '1' and False means '0'.

2) Default value of Relay is a False.

6. Technical Data

6.1. Physical Characteristics

The Feature of Board

[Unit: mm]

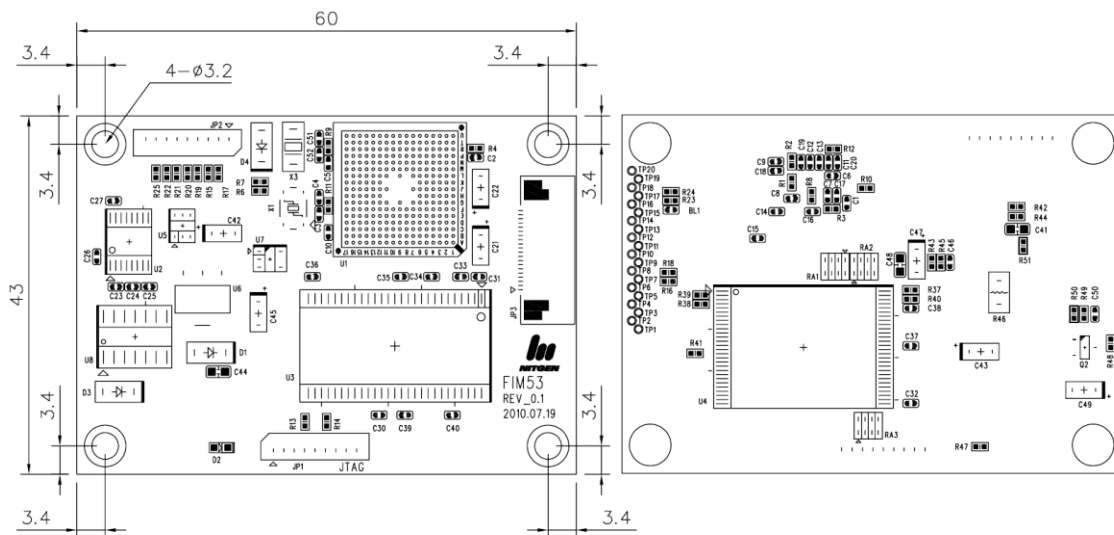

FIM5360

The feature of fingerprint sensor

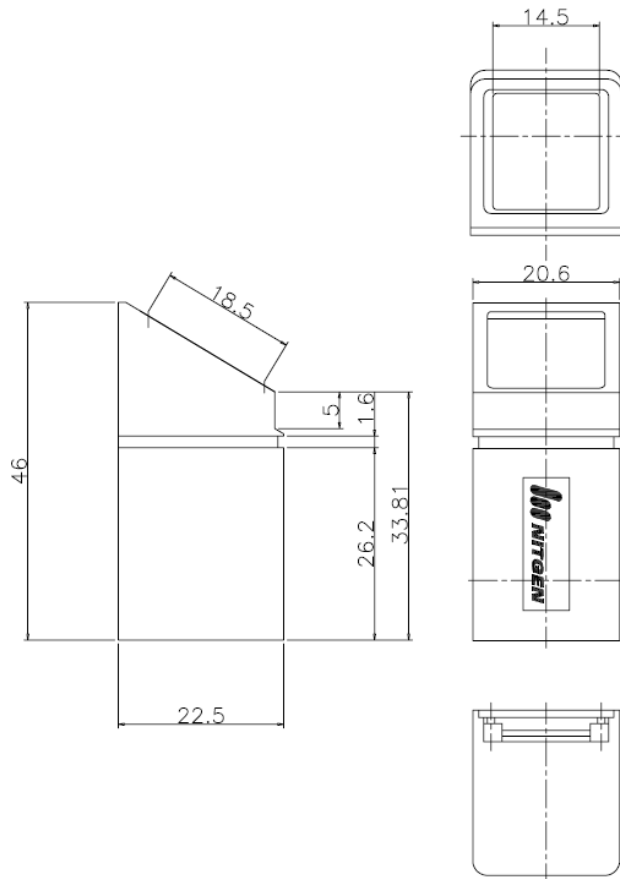

The Dimension of OPP06 [Unit : mm]

The feature of sensor Cable

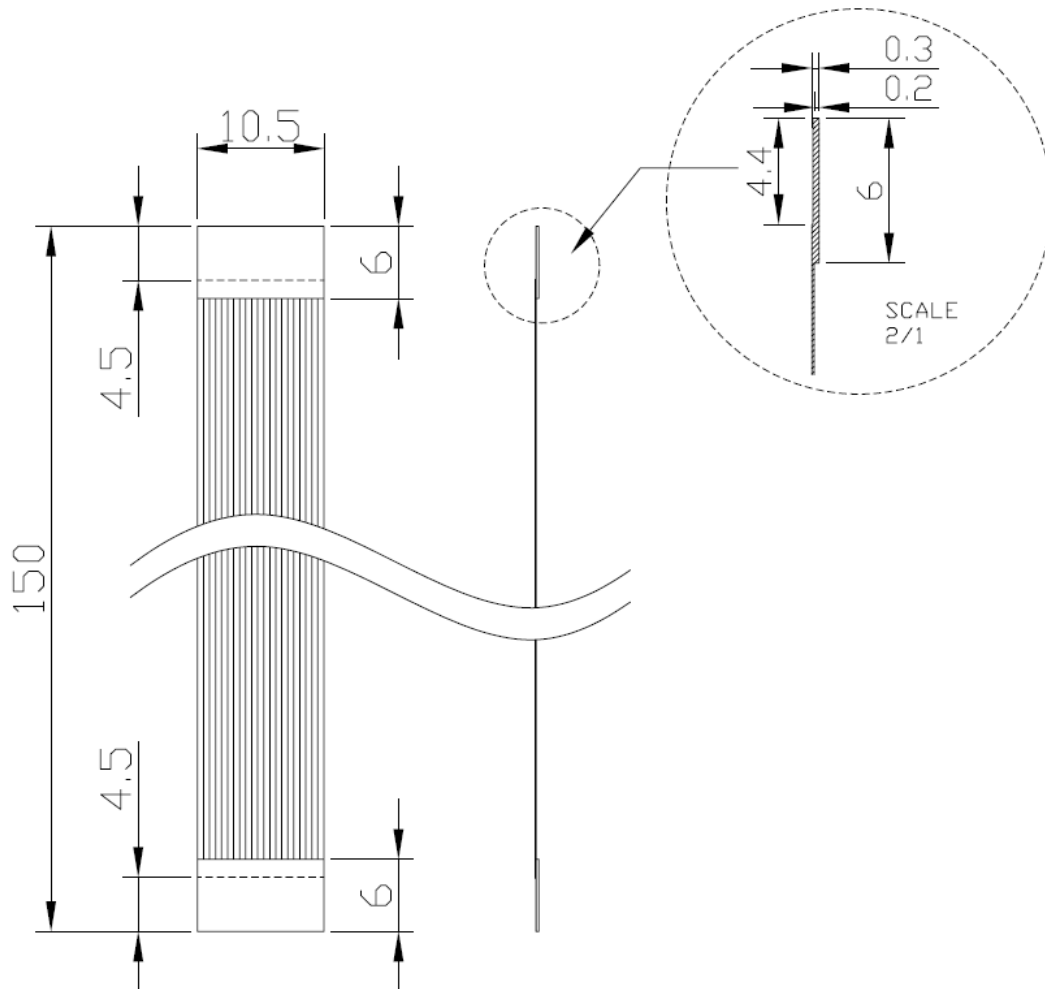

6.2. External Port

- **JTAG Connector (JP1)**

Pin	Pin Name	Description
1	VCC	3.3 Volt Power
2	N/A	N/A
3	nSRST	JTAG control pin
4	TDO	JTAG control pin
5	TDI	JTAG control pin
6	nTRST	JTAG control pin
7	TCK	JTAG control pin
8	TMS	JTAG control pin
9	GND	Ground

* JP1 (JTAG connector) is used only for development or emergency recovery.

- **9-Pin External Connector (JP2)**

Pin	Pin Name	Description
1	VCC	Supply Voltage (HV – 5V, LV – 3.3V)
2	EXT_RXD	UART Channel 1 port receiving signal from host (RS232 Level)
3	EXT_TXD	UART Channel 1 port transmitting signal to host (RS232 Level)
4	GPIO0	General Purpose Input / Output 0
5	GPIO1	General Purpose Input / Output 1
6	GPIO2	General Purpose Input / Output 2
7	GPIO3	General Purpose Input / Output 3
8	GPIO4	General Purpose Input / Output 4
9	GND	Ground

● **20-Pin OPP06 Sensor connector (JP3)**

Name	No	States	Description
GND	1	POWER	Sensor Ground
VCLK	2	OUT	Sensor System Clock
VCC	3	POWER	Sensor VCC (3.3V)
AUTOON	4	IN	Sensor Auto-On
	5		Reserved
VSYNC	6	IN	Vertical Sync.
HSYNC	7	IN	Horizontal Sync.
SDATA0	8	IN	Sensor Data 0
SDATA1	9	IN	Sensor Data 1
SDATA2	10	IN	Sensor Data 2
SDATA3	11	IN	Sensor Data 3
SDATA4	12	IN	Sensor Data 4
SDATA5	13	IN	Sensor Data 5
SDATA6	14	IN	Sensor Data 6
SDATA7	15	IN	Sensor Data 7
SDA	16	IN/OUT	I2C Data
SCL	17	OUT	I2C Clock
LED 1	18	OUT	Sensor LED 1
PIXCLK	19	IN	Pixel Clock
LED 2	20	OUT	Sensor LED 2

6.3. Connector

Sensor

Material List

NO	DESCRIPTION	VENDOR
1	20-PIN (52746-2090)	MOLEX

Communication

Material List

NO	DESCRIPTION	VENDOR
1	9-pin Male (53047-0910)	MOLEX
2	8-pin Male (53047-0810)	MOLEX

6.4. Electrical Characteristics

Parameter	MIN.	TPY.	MAX.	UNITS
Power				
Supply current			300	mA
Supply Voltage (HV Model)	4.5	5.0	5.5	V
Supply Voltage (LV Model)	3.0	3.3	3.6	V
UART (RS-232 Level)				
Output Voltage Swing	±5.0	±5.4		V
Input Voltage Range	-15		+15	V
Input Threshold LOW	0.6	1.2		V
Input Threshold HIGH		1.5	2.4	V
Maximum data rate			115,200	BPS
GPIO				
Output Voltage LOW			0.4	V
Output Voltage HIGH	2.7			V
Input Threshold LOW			0.8	V
Input Threshold HIGH	2.4		3.3	V
Etc				
Reset pulse Width	1			ms

7. Ordering Information

7.1. FIM5360 Ordering Guide

Product Name	Max. Templates	Supply Voltage [V]	RTC
FIM5360-HV	2,000	5	Internal
FIM5360-LV	2,000	3.3	Internal

FIM5360

7.2. Naming Rule

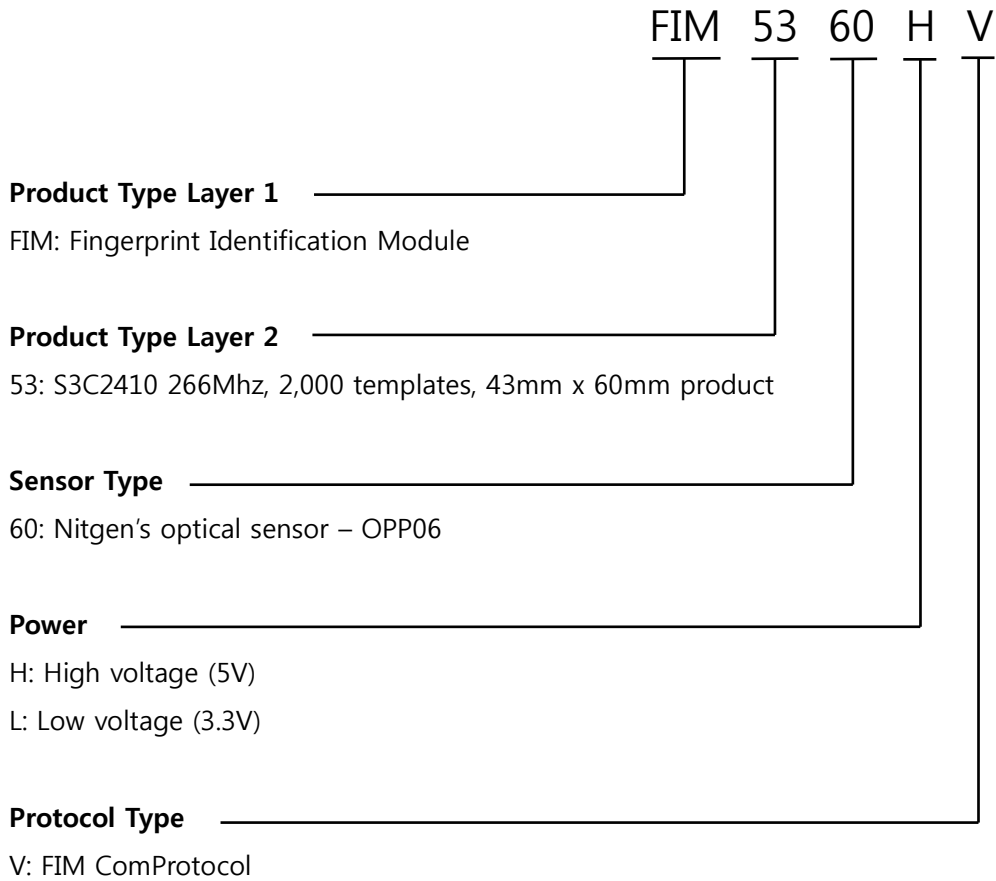

APPENDIX

Recommended circuit to use GPIOs

- Key Input – Enroll, Delete, Delete All and Identify

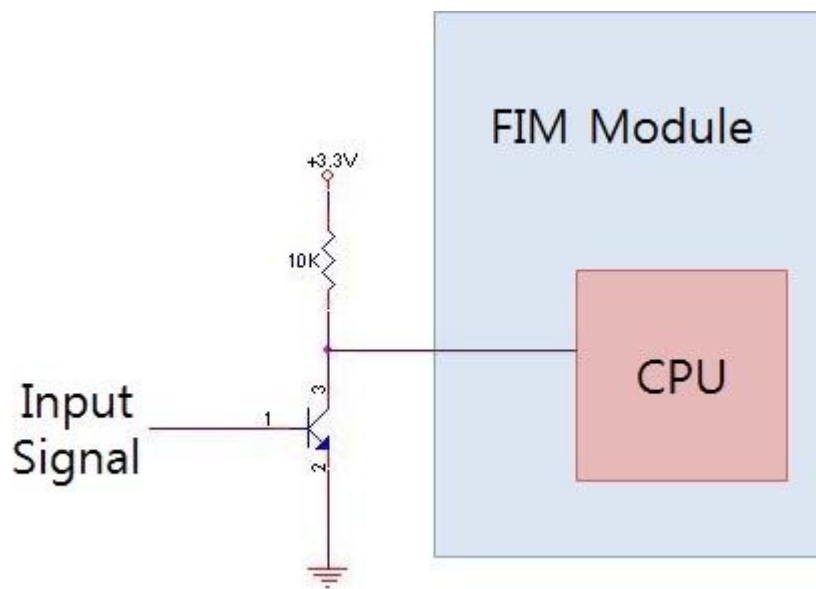

- Relay Output 0, 1 and Result Output

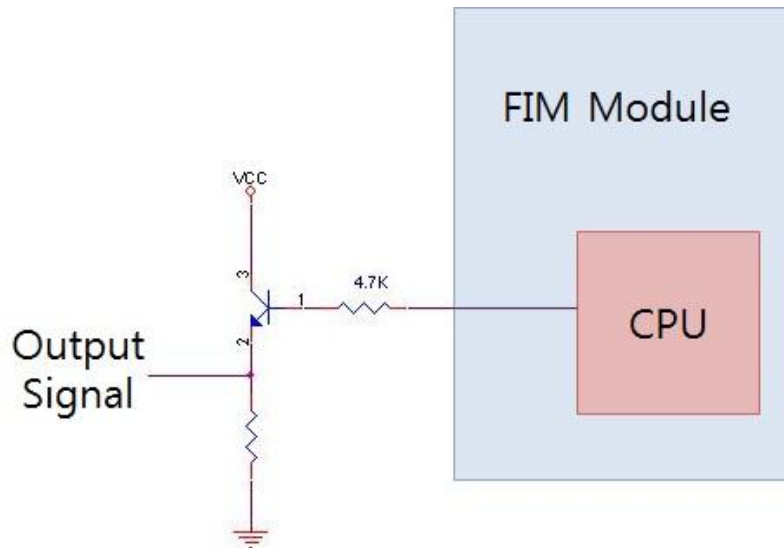

Or,

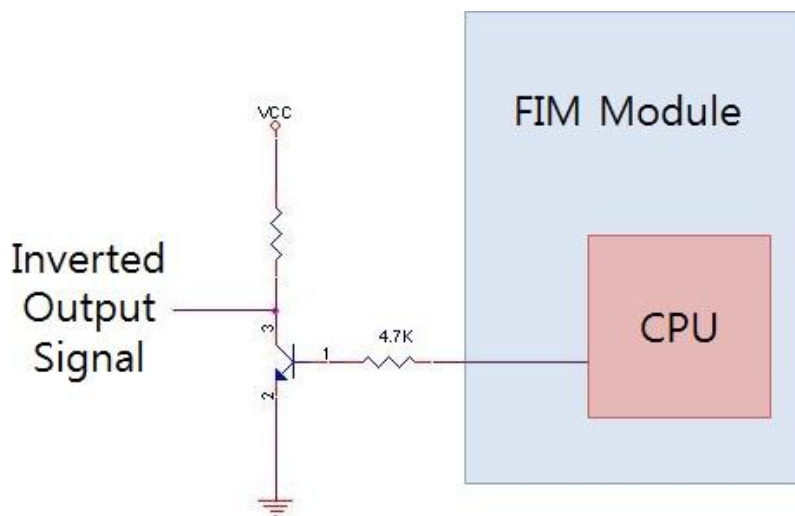

Boot up time

System Boot-up time means the total time consumed by FIM5360 after system power and **/Reset** are supplied.

System Boot-up time can be measured as the following.

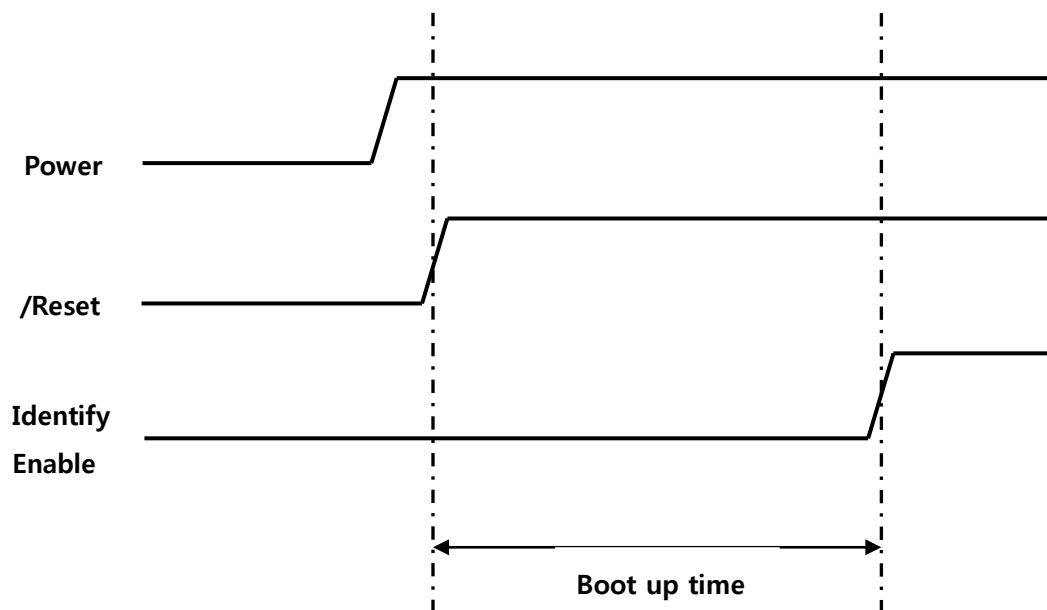

Support Information



NITGEN&COMPANY CO., LTD.

12F PaxTower Nonhyun-dong, Gangnam-gu,
Seoul, 135-010 Korea
Tel: +82-2-556-7115
Fax: +82-2-556-7118
E-mail: Customer@nitgen.com