

## Description

The ZMOD4450 Gas Sensor Module is designed for detecting gases associated with food ripening or rotting and is targeted for use in refrigeration air quality (RAQ) applications; for example, food storage and shipping. The sensor is a 12-pin LGA assembly (3.0 × 3.0 × 0.7 mm) that consists of a gas sense element and a CMOS signal conditioning IC. The module's sense element consists of a heater element on a silicon-based MEMS structure and a metal temperature sensor. It measures the MOx conductivity, which is a function of the gas concentration.

The measurement results can be read via an I2C interface with the user's microprocessor, which processes the data to determine the levels of gases present and to indicate the likelihood of food spoilage. With the ZMOD4450's low operating current consumption, the sensor is an excellent choice for low-voltage and low-power battery applications. Built-in nonvolatile memory (NVM) stores the configuration and provides space for arbitrary user data.

## Typical Applications

- Refrigerator systems control
- Measurement of fruit and vegetable quality
- Monitors for fruit and vegetable shipping and storage conditions for fruit and vegetable quality

## Physical Characteristics

- Target operation temperature: 0°C to 25°C
- Supply voltage: 1.7V to 3.6V
- Package: 12-LGA
- Assembly size: 3.0 × 3.0 × 0.7 mm

## Available Support

- ZMOD4450 Evaluation Kit
- Manuals, application notes, and white papers
- Instructional videos
- Programming libraries, example codes, and algorithm support to optimize performance

## Features

- Measurement of gases associated with food ripening and storage: ethylene, amines, volatile sulfur compounds
- Configurable methods of operation based on application and use case
- Heater driver and regulation loop for constant heater voltage or constant heater resistance
- Internal auto-compensated temperature sensor; not stress sensitive
- I2C interface: up to 400kHz
- Configurable alarm/interrupt output with static and adaptive levels
- Adjustable ADC resolution for optimal speed versus resolution: 16-bit maximum
- Built-in nonvolatile memory (NVM) for user data
- Low average power consumption in the mW range
- Firmware upgradable platform for application optimizations, such as ultra-low-power battery applications
- No external trimming components required
- External reset pin (active-LOW)
- Customization for mobile and consumer applications
- Siloxane resistant

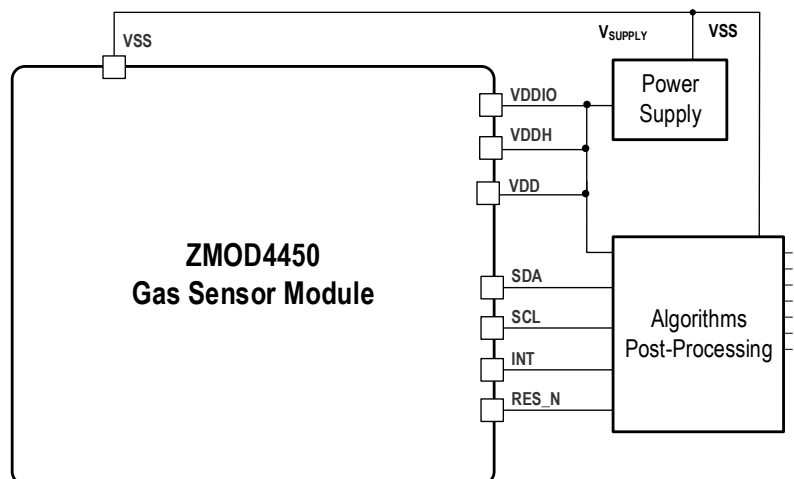

## Contents

1. Pin Assignments.....	4
2. Pin Descriptions.....	4
3. Absolute Maximum Ratings.....	5
4. Operating Conditions.....	5
5. Electrical Characteristics.....	6
6. Block Diagram.....	7
7. Sensor Module Characteristics.....	8
7.1 Gas Sensor Module.....	8
8. Gas Sensor Module Characteristics.....	9
8.1 Characteristics for Typical Gas Stimulation.....	9
8.2 Environmental Temperature and Humidity.....	10
8.3 Accuracy and Conditioning.....	10
9. Package Outline Drawings.....	11
10. Assembly Restrictions, Operation, and Integration Notes.....	11
11. Test and Calibration.....	12
12. I2C Interface and Data Transmission Protocol.....	12
13. Glossary.....	14
14. Ordering Information.....	15
15. Revision History.....	15

## List of Figures

Figure 1. ZMOD4450 Pin Assignments for 12-LGA Module – Top View.....	4
Figure 2. Gas Response to Typical Gases and Levels of Expected Refrigeration Gases.....	9
Figure 3. Humidity Influence at 4°C for Ethylene Stimulation.....	10
Figure 4. Typical Solder Profile.....	11
Figure 5. I2C Data Transmission Protocol.....	12
Figure 6. Bus Timing.....	13

---

## List of Tables

Table 1.	ZMOD4450 Pin Descriptions .....	4
Table 2.	Absolute Maximum Ratings .....	5
Table 3.	Operating Conditions .....	5
Table 4.	ZMOD4450 Electrical Characteristics .....	6
Table 5.	Gas Sensor Module Specifications .....	8
Table 7.	Default Parameters for Control Signal based on Air Quality Changes .....	9
Table 8.	Typical ZMOD4450 Sensor Module Accuracy Achievable with Calibration .....	10
Table 9.	Final Test Parameters .....	12
Table 10.	Bus Timing Characteristics .....	13

## 1. Pin Assignments

**Figure 1. ZMOD4450 Pin Assignments for 12-LGA Module – Top View**

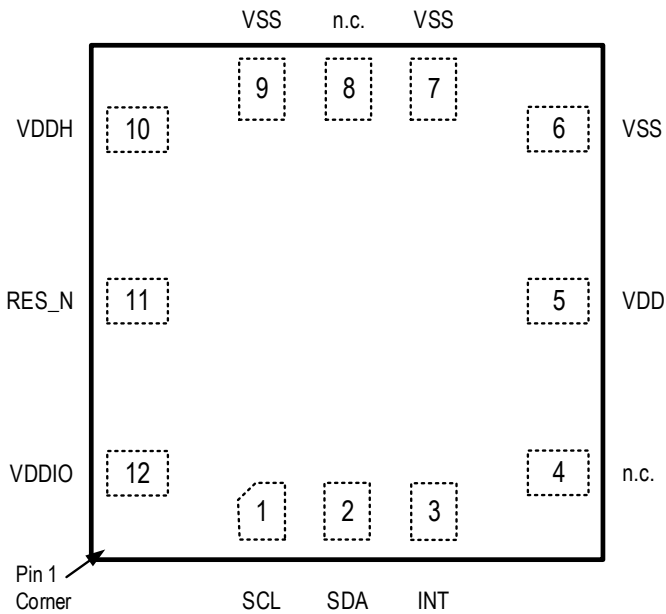

## 2. Pin Descriptions

**Table 1. ZMOD4450 Pin Descriptions**

Pin Number	Name	Type	Description
1	SCL	Input	Serial clock for the I2C interface.
2	SDA	Input/Output	Serial data for the I2C interface. Default 7-bit slave address: 32 <sub>HEX</sub> .
3	INT	Output	Interrupt signal (push-pull).
4	n.c.	–	Do not connect.
5	VDD	Supply	Voltage supply for the ZMOD4450.
6	VSS	Ground	Ground reference for the ZMOD4450.
7	VSS	Ground	Ground reference for the ZMOD4450.
8	n.c.	–	Do not connect.
9	VSS	Ground	Ground reference for the ZMOD4450.
10	VDDH	Supply	Voltage supply for the integrated heater in the ZMOD4450.
11	RES_N	Input	ZMOD4450 reset; active low.
12	VDDIO	Supply	Voltage supply for I/O-interface in ZMOD4450.

### 3. Absolute Maximum Ratings

Note: The absolute maximum ratings are stress ratings only. The ZMOD4450 might not function or be operable below and above the recommended operating conditions given in Table 3. Stresses exceeding the absolute maximum ratings will change the sensor accuracy; lead to imprecision, and eventually cause irreversible damage to the device. In addition, extended exposure to stresses above the recommended operating conditions might affect device reliability. IDT does not recommend designing to the “Absolute Maximum Ratings.”

**Table 2. Absolute Maximum Ratings**

Symbol	Parameter	Minimum	Typical	Maximum	Units
$V_{DD}, V_{DDH}, V_{DDIO}$	Maximum Analog and I/O Supply Voltage	-0.4		3.63	V
$V_{A\_IO}, V_{D\_IO}$	Maximum Voltage at all Analog and Digital I/O Pins	-0.5		$V_{DDIO} + 0.5$	V
	Maximum Difference in Voltage between VDD and VDDH Pins	–		0.4	V
$I_{IN}$	Input Current into any Pin Except Supply Pins (Latch-Up Immunity)	-100		100	mA
$V_{HBM1}$	Electrostatic Discharge Tolerance – Human Body Model (HBM)	2000		–	V
$V_{CDM}$	Electrostatic Discharge Tolerance – Charged Device Model (CDM) on Packaged Module	750		–	V
$T_{OPERATION}$	Operation Temperature of Sense Element		300		°C
$T_{STOR}$	Storage Temperature	-50		125	°C

### 4. Operating Conditions

Note: The reference for all voltages is  $V_{SS}$ .

**Table 3. Operating Conditions**

Symbol	Parameter	Min	Typ	Max	Unit
$V_{DD}$	Supply Voltage for ZMOD4450 Sensor Module	1.7	–	3.6	V
$T_{AMB}$	Ambient Temperature Range for Sensor Operation	0	–	25	°C

## 5. Electrical Characteristics

Values below are valid at operating conditions unless noted otherwise.

**Table 4. ZMOD4450 Electrical Characteristics**

Symbol	Parameter	Conditions	Minimum	Typical	Maximum	Unit
	Average Power ZMOD4450	Continuous Operation	–	23	–	mW
I <sub>ACTIVE</sub>	Supply Current, Active Mode including Heater Current.	At V <sub>DD</sub> = 1.8V		13		mA
		At V <sub>DD</sub> = 3.3V		7		mA
I <sub>SLEEP_Timer</sub>	Supply Current, Sleep Mode ASIC with Wake-up Timer Active	Does not include heater current	–	–	500	μA
I <sub>SLEEP</sub>	Supply Current, Sleep Mode ASIC, No Wake-up Timer Active	Does not include sensor heater current	–	450	–	nA
PSRR	Power Supply Rejection Ratio	V <sub>DD</sub> ≥ 2.0V	–	30	–	dB
	Timing Accuracy (Valid for Measurements Only) (Sleep Timer is ±20%)	At room temperature; for timings derived from the internal clock	-2	–	2	%
		Over-temperature range; for timings derived from the internal clock	-0.1	–	0.1	%/K
r <sub>ADC</sub>	ADC Resolution		10	–	16	Bit
t <sub>meas</sub>	ADC Conversion Time	10-bit, no auto-zero	–	0.238	–	ms
		10-bit, auto-zero	–	0.476	–	ms
		16-bit, auto-zero	–	3.36	–	ms
V <sub>ref</sub>	Reference Voltage		–	1.5	–	V
I <sub>HTR_meas</sub>	Heater Resistance Measurement Current	HTR_range = 0	–	0.4	–	mA
		HTR_range = 1	–	0.6	–	mA
		HTR_range = 2	–	1.0	–	mA
t <sub>STA1</sub>	Start-up Time: V <sub>DD</sub> Ramp up to Interface Communication		–	–	1	ms
t <sub>STA2</sub>	Start-up Time: V <sub>DD</sub> Ramp up to Analog Operation		–	–	2.5	ms
t <sub>WUP1</sub>	Wake-up Time for Sleep to Active Mode: Interface Communication		–	–	0.5	ms
t <sub>WUP2</sub>	Wake-up Time for Sleep to Active Mode: Analog Operation		–	–	2	ms
f <sub>c,I2C</sub>	I2C Clock Frequency		–	–	400	kHz
t <sub>VPP</sub>	NVM Programming Time		–	6	16	ms
t <sub>RET_FTP</sub>	Data Retention	85°C junction temperature	10	–	–	years
	NVM Programming Cycles		1000	–	–	cycles
	Default Communication Address	7-bit slave address	–	32 <sub>HEX</sub>	–	–
	Blocking Capacitor for Power Supply	Recommended; ceramic type	100	–	–	nF

## 6. Block Diagram

Note: See section 12 for definitions of abbreviations.

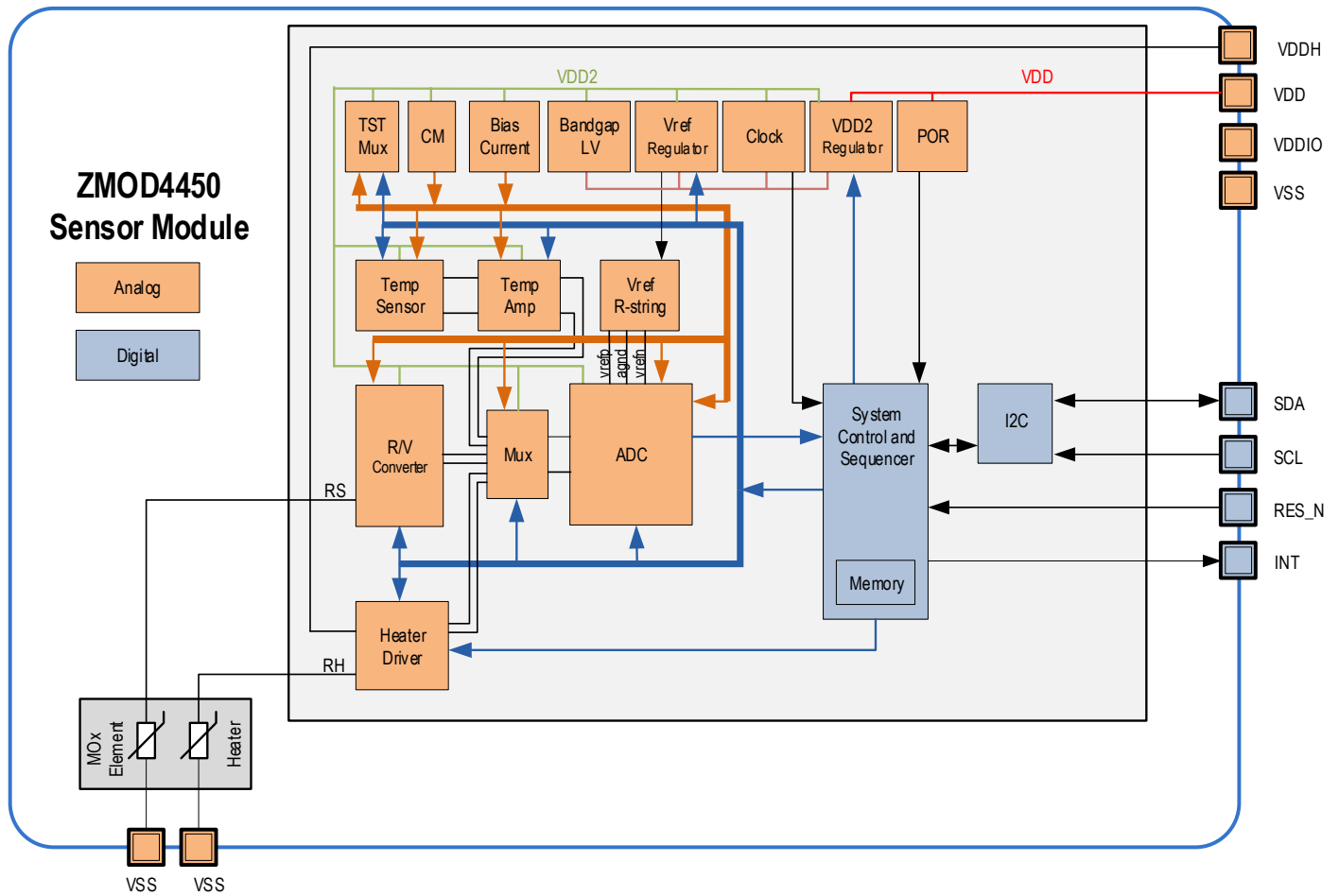

## 7. Sensor Module Characteristics

### 7.1 Gas Sensor Module

The ZMOD4450 Gas Sensor Module is designed to detect typical gases inside refrigeration applications associated with food ripening or rotting. Specifications for sensor operation are shown in Table 5. The response time for a gas stimulation is always within a few seconds, depending on the gas and its concentration. An active or direct airflow onto the sensor module is not necessary since diffusion of ambient gas does not limit the sensor response time.

The ZMOD4450 is also able to detect some safety-relevant toxic gases; however, the sensor is not designed to detect these interferants reliably, and it therefore is not approved for use in any safety-critical or life-protecting applications. It must not be used in such applications, and IDT disclaims all liability for any such use.

**Table 5. Gas Sensor Module Specifications**

Symbol	Parameter	Conditions	Minimum	Typical	Maximum	Unit <sup>[a]</sup>
	Measurement Range	Ethylene (C <sub>2</sub> H <sub>4</sub> ) in air	0		10	ppm
	Measurement Range	Trimethylamine (C <sub>3</sub> H <sub>9</sub> N) in air	0		600	ppb
	Measurement Range	Dimethyl sulfide (C <sub>2</sub> H <sub>6</sub> S) in air	0		180	ppb
	Humidity Range	Non-condensing	0		95	% RH
	Temperature Range		0		25	°C
	Repeatability	Variation in sensor signal		±10		%
T-90	Response Time	Time to change to 90% of end value		10		sec

[a] The abbreviation ppm stands for “parts per million,” and ppb is an abbreviation for “parts per billion.” For example, 1 ppm equals 1000 ppb.



## 8. Gas Sensor Module Characteristics

Further details for sensitivity and sensor influences are explained in detail in the following sections. All graphs and information show the typical responses that are to be expected from the ZMOD4450 Gas Sensor Module upon exposure to a variety of test conditions. For additional information, including application notes, white papers, blog, and manuals, visit [www.idt.com/ZMOD4450](http://www.idt.com/ZMOD4450).

### 8.1 Characteristics for Typical Gas Stimulation

The ZMOD4450 also allows controlling an external device, such as an active air filter or ozone generator, based on the air quality changes. Although the sensor is not selective to an individual gas, it detects a variety of volatile organic and sulfur compounds.

**Figure 2. Gas Response to Typical Gases and Levels of Expected Refrigeration Gases**

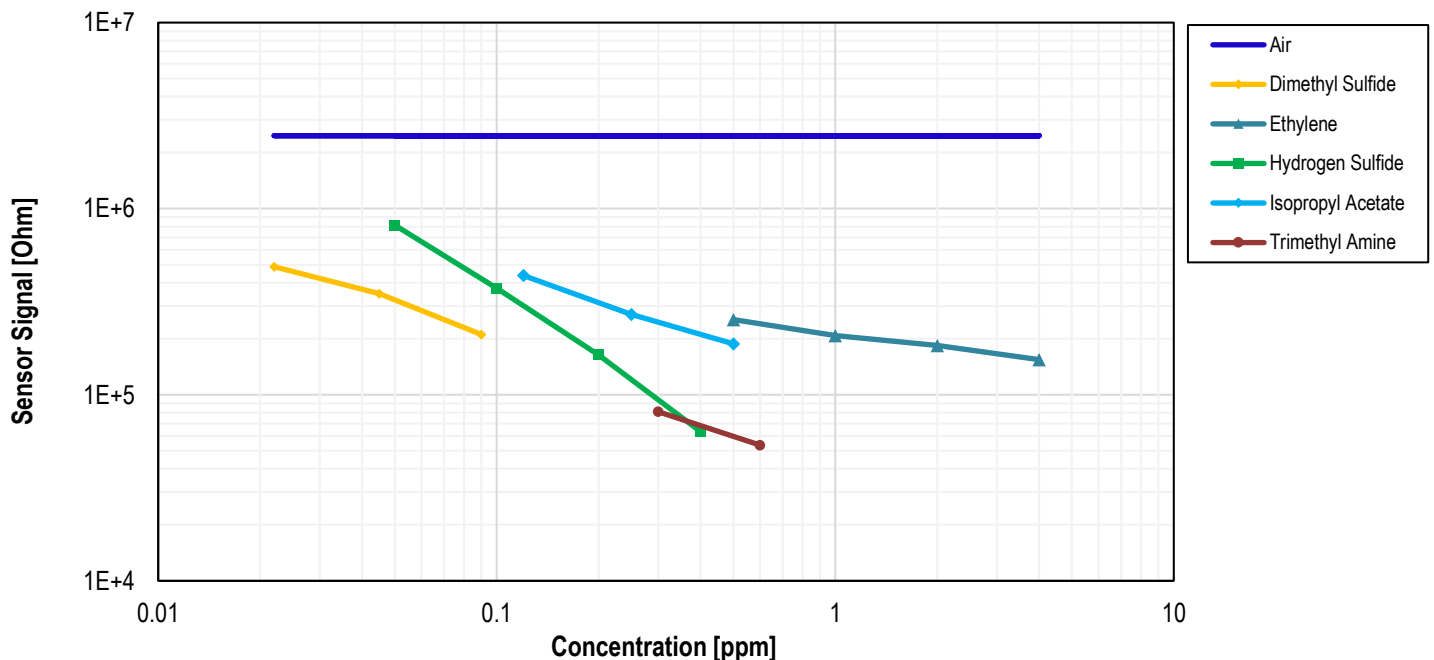

IDT provides firmware and algorithms, which allow the ZMOD4450 to learn the refrigeration environment. The gas sensor module will immediately respond to changes in the refrigeration air by detecting changes in the relative gas concentrations. When a user-defined threshold is exceeded, an I/O control signal (trigger) based on the algorithm output can be used to control an external device.

**Table 6. Default Parameters for Control Signal based on Air Quality Changes**

Parameter	Conditions	Typical Value	Unit
Learning Time Environment	Typical value valid for sample rate of 10 seconds	60	min
Sensor Response Time	Sample rate dependent, typically 1 sample	10	s
Threshold Trigger	Change of raw sensor signal; recommended difference: 30%	1.3	-
Stop Delay	Stop delay for external device; defines minimum activation time	2	min

When using the ZMOD4450 Evaluation Kit, the AD5 pin (GPIO) on connector K3 on the HiCom Communication Board is the trigger control signal output that is set to HIGH/LOW. For more details, refer to the ZMOD4450 Evaluation Kit User Manual.

## 8.2 Environmental Temperature and Humidity

The sensor module is tested, qualified, and functional in the operation range of 0°C to +25°C. Figure 3 shows the module’s response during operation to variations in relative humidity with and without ethylene stimulation.

**Figure 3. Humidity Influence at 4°C for Ethylene Stimulation**

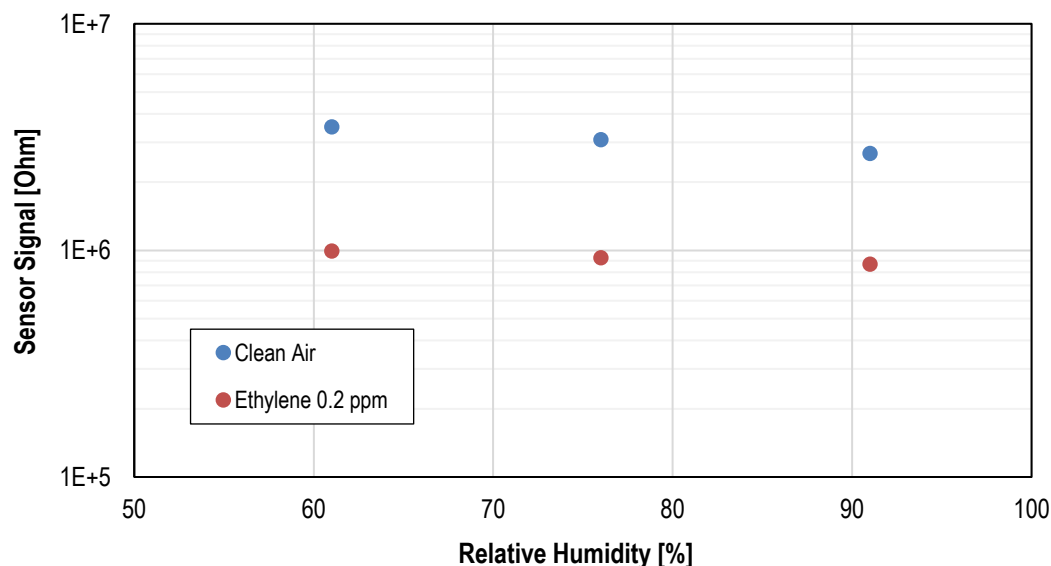

## 8.3 Accuracy and Conditioning

All IDT gas sensor modules come with electrical and chemical factory calibration with data stored in the module’s nonvolatile memory (NVM). Using the software provided by IDT and the calibration coefficients in the NVM will lead to stable measurements. The ZMOD4450 will respond to typical refrigeration gases immediate upon start-up; however, a conditioning period of 48 hours in a refrigeration environment is recommended to improve stability and get maximum performance, as the module algorithm is able to learn about the refrigeration environment over time.

Users who require an absolute measurement with the maximum achievable accuracy are advised to re-calibrate the sensor with a known organic compound. This enables an absolute accuracy of ±15%; see Table 7. For some environments, an interference response to siloxanes is of concern; however, IDT’s ZMOD4450 gas sensors have been proven to be resistant against siloxanes. A maximum potential life-time exposure has been simulated in all ZMOD4450 operation modes by applying the chemicals D4 (octamethylcyclotetrasiloxane) and D5 (decamethylcyclopentasiloxane) in high concentration for several hundred hours.

**Table 7. Typical ZMOD4450 Sensor Module Accuracy Achievable with Calibration**

Symbol	Parameter	Conditions	Minimum	Typical	Maximum	Unit
	Accuracy	With additional calibration		±15		%
	Durability to Siloxanes	Change in sensitivity		±5		%

## 9. Package Outline Drawings

The package outline drawings are appended at the end of this document and are accessible from the link below. The package information is the most current data available.

<https://www.idt.com/document/psc/12-lga-package-outline-drawing-30-x-30-x-07-mm-body-05-x-10-mm-pitch-lgg12d1>

## 10. Assembly Restrictions, Operation, and Integration Notes

When implementing the ZMOD4450 in electrical circuit boards, it should be understood that a gas sensor module might react to chemicals during the assembly process and to outgassing components, such as resins from the printed circuit board (PCB) assembly. A standard soldering profile can be used to assemble the ZMOD4450 on the user's PCB and should fulfill the IPC/JEDEC J-STD-020C Standard ("Moisture/Reflow Sensitivity Classification for Non-hermetic Solid State Surface Mount Devices"). A typical lead-free reflow solder profile is shown in Figure 4. After assembly, an outgassing of the PCB and electronic components must be considered, especially when operating the sensor module at elevated temperatures. This will ultimately influence the sensor signal and may dominate the air quality reading. A PCB heat treatment before assembling the ZMOD4450 is recommended. After the gas sensor module assembly, no coating, cleaning, or ultrasonic bath should be applied to the PCB. Also, after assembly, IDT recommends cleaning the sensor module by operating it at 450°C for 10 min to remove any contamination of solder vapor.

To operate the ZMOD4450, the software and libraries provided by IDT can be used. For implementing the sensor module in a customer-specific application, detailed information on the programming is available. The *ZMOD4450 Programming Manual - Read Me* explains documentation, libraries, and code examples for an easy integration.

**Figure 4. Typical Solder Profile**

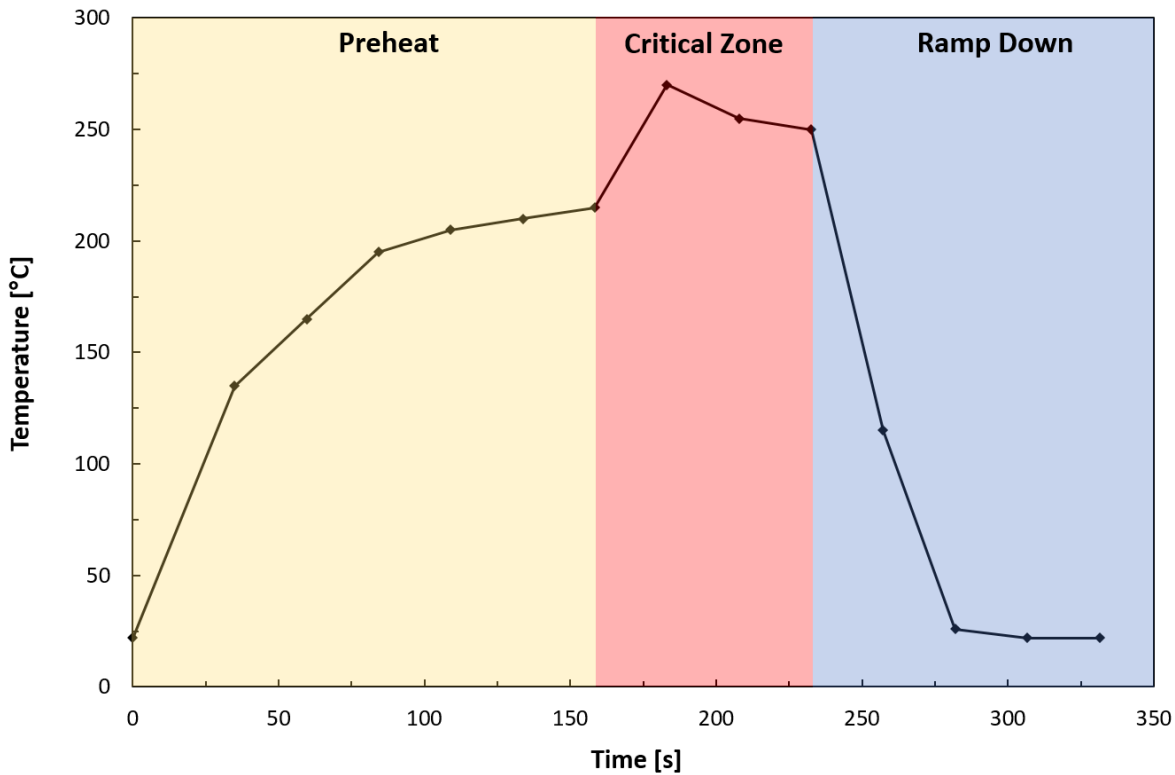

## 11. Test and Calibration

As a unique feature, all sampled gas sensor modules are fully tested during IDT's final test. The final test parameters in Table 8 are applied for each ZMOD4450. All sensor modules are additionally pre-stabilized in the final test; although the user might see a small change in the module's raw signal during an initial warm-up phase during the first operation. The gas sensor module qualification is based on JEDEC (JESD47) and its subsequent standard (JESD22, JESD78, etc.).

**Table 8. Final Test Parameters**

Test	Test Object	Parameters	Test Results Saved in NVM?
Electrical	ASIC	Voltages, current consumption, frequencies, scan pattern	No
Electrical	Module	Calibration conditions, tracking ID, resistances	Yes
Gas	Module	Sensitivity parameters (slope and intercept) at stimulation with different gas concentrations	Yes
Gas	Module	Pre-stabilization	No

## 12. I2C Interface and Data Transmission Protocol

The I2C slave device interface supports various bus speeds: Standard Mode ( $\leq 100\text{kHz}$ ) and Fast Mode ( $\leq 400\text{kHz}$ ).

By default, the 7-bit slave address for the serial I2C data interface is set to 32<sub>HEX</sub>. The implemented data transmission protocol is similar to the one used for conventional EEPROM devices. The register to read/write is selected by a register address pointer. This address pointer must be set during an I2C WRITE operation. After transmission of a register, the address pointer is automatically incremented. An increment from the address FF<sub>HEX</sub> rolls over to 00<sub>HEX</sub>. See Figure 5 for an illustration of the data transmission protocol and Figure 5 for a diagram of the bus timing. Table 9 gives the I2C bus characteristics.

Recommendation: To validate the READ/WRITE access, write random values to registers 88<sub>HEX</sub> to 8B<sub>HEX</sub> and then read these addresses to confirm new values. After this register test, reset the device by disconnecting the power support; otherwise the device might not operate properly.

**Figure 5. I2C Data Transmission Protocol**

### WRITE Access RAM

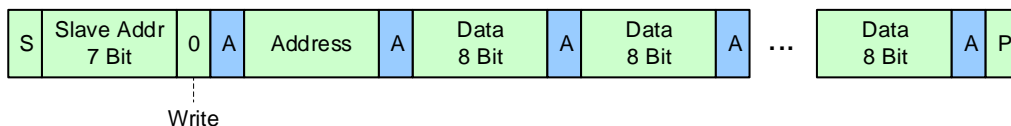

### READ Access NVM and RAM

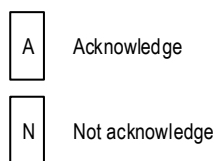
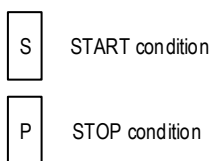
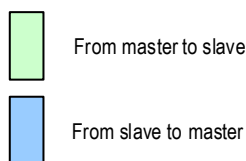
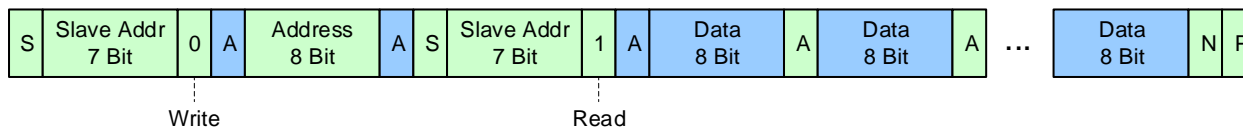

**Figure 6. Bus Timing**

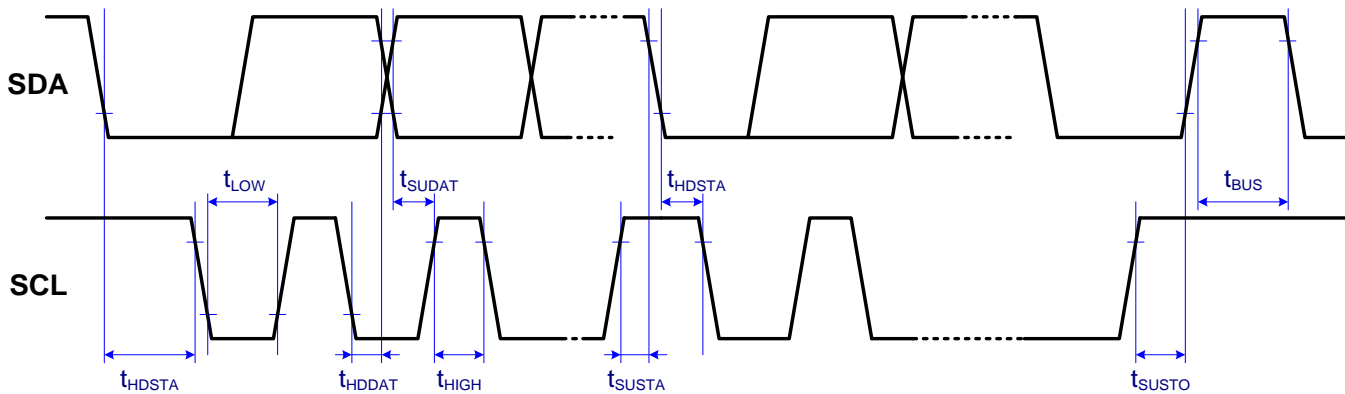

**Table 9. Bus Timing Characteristics**

Parameter	Symbol	Standard Mode	Fast Mode	Units
Maximum SCL clock frequency	$f_{SCL}$	100	400	kHz
Minimum START condition hold time relative to SCL edge	$t_{HDSTA}$	4		$\mu s$
Minimum SCL clock LOW width	$t_{LOW}$	4.7		$\mu s$
Minimum SCL clock HIGH width	$t_{HIGH}$	4		$\mu s$
Minimum START condition setup time relative to SCL edge	$t_{SUSTA}$	4.7		$\mu s$
Minimum data hold time on SDA relative to SCL edge	$t_{HDDAT}$	0		$\mu s$
Minimum data setup time on SDA relative to SCL edge	$t_{SUDAT}$	0.1	0.1	$\mu s$
Minimum STOP condition setup time on SCL	$t_{SUSTO}$	4		$\mu s$
Minimum bus free time between stop condition and start condition	$t_{BUS}$	4.7		$\mu s$

## 13. Glossary

Term	Description
ADC	Analog-to-Digital Converter
CDM	Charged Device Model
CM	Common Mode Generator
HBM	Human Body Model
LGA	Land Grid Array
LV	Low Voltage
MOx	Metal Oxide
MSL	Moisture Sensitivity Level
Mux	Multiplexer
n.a.	Not Applicable
NVM	Nonvolatile Memory
POR	Power-On Reset
SDA	Serial Data
SCL	Serial Clock
RAQ	Refrigeration Air Quality
SSC	Sensor Signal Conditioner
TST	Test

## 14. Ordering Information

Orderable Part Number	Description and Package	MSL Rating	Carrier Type	Temperature
ZMOD4450AI1V	ZMOD4450 Sensor Module, 3.0 × 3.0 × 0.7 mm 12-LGA	3	Tray	0°C to +25°C
ZMOD4450AI1R	ZMOD4450 Sensor Module, 3.0 × 3.0 × 0.7 mm 12-LGA	3	Reel	0°C to +25°C
ZMOD4450-EVK-HC	ZMOD4450 Evaluation Kit, including the ZMOD4450 Sensor Board, HiCom Communication Board (USB Interface), and Micro-USB Cable. The ZMOD4450 Evaluation Software is available for download free of charge on <a href="http://www.IDT.com/ZMOD4450-EVK">www.IDT.com/ZMOD4450-EVK</a> .			

## 15. Revision History

Revision Date	Description of Change
October 30, 2019	<ul style="list-style-type: none"> <li>▪ MSL rating corrected in the Ordering table.</li> <li>▪ Product name corrected.</li> </ul>
March 7, 2019	<ul style="list-style-type: none"> <li>▪ Addition of I2C specification.</li> <li>▪ Revision for URL for software.</li> </ul>
December 12, 2018	Initial release.

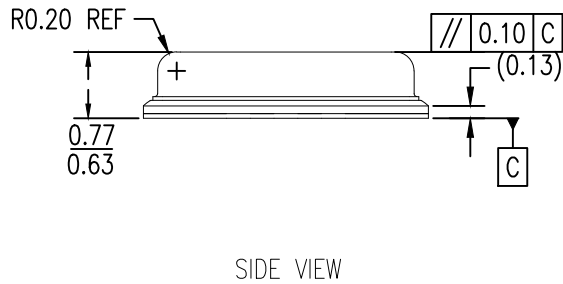
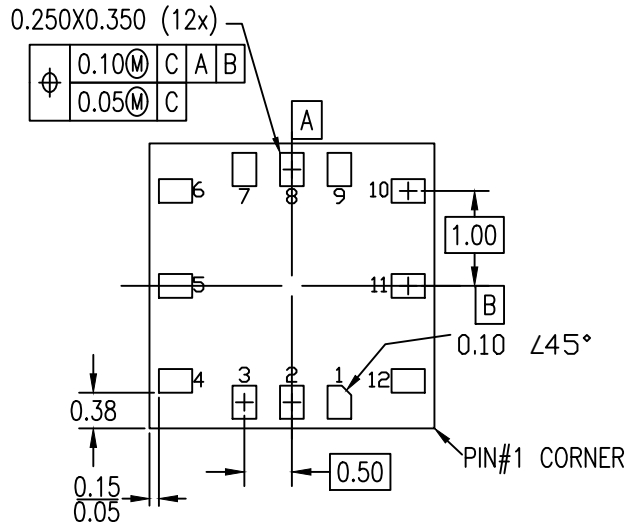
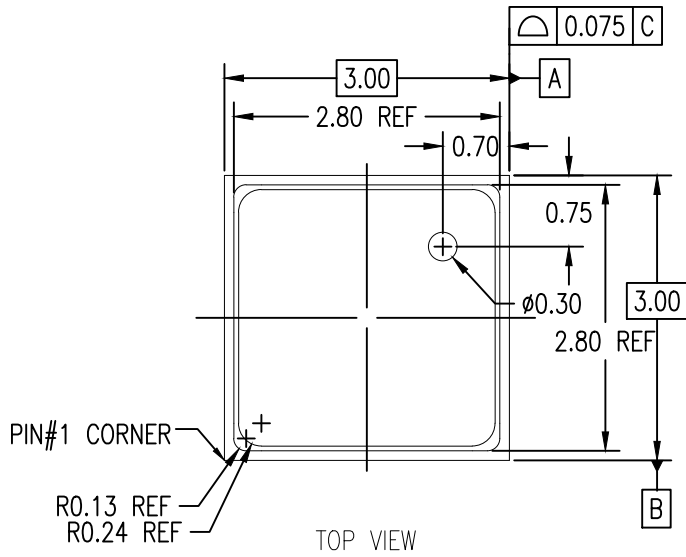

NOTES:

1. ALL DIMENSIONING AND TOLERANCING CONFORM TO ANSI Y14.5M-1982
2. ALL DIMENSION ARE IN MILLIMETERS.



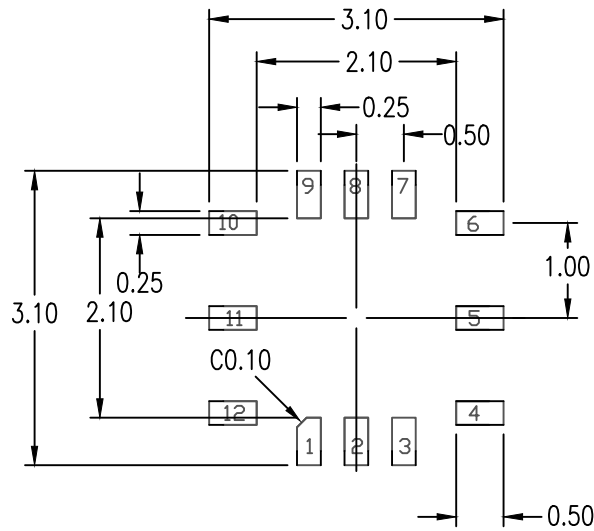

RECOMMENDED LAND PATTERN DIMENSION

NOTES:

1. ALL DIMENSION ARE IN MM. ANGLES IN DEGREES.
2. TOP DOWN VIEW. AS VIEWED ON PCB.
3. LAND PATTERN RECOMMENDATION PER IPC-7351B GENERIC REQUIREMENT FOR SURFACE MOUNT DESIGN AND LAND PATTERN.

Package Revision History		
Date Created	Rev No.	Description
Sept 12, 2019	Rev 01.	Add Dimension on Gal Inlet Hole
Dec 17, 2019	Rev 02	Add Location Dimension Gal Inlet

## IMPORTANT NOTICE AND DISCLAIMER

RENESAS ELECTRONICS CORPORATION AND ITS SUBSIDIARIES (“RENESAS”) PROVIDES TECHNICAL SPECIFICATIONS AND RELIABILITY DATA (INCLUDING DATASHEETS), DESIGN RESOURCES (INCLUDING REFERENCE DESIGNS), APPLICATION OR OTHER DESIGN ADVICE, WEB TOOLS, SAFETY INFORMATION, AND OTHER RESOURCES “AS IS” AND WITH ALL FAULTS, AND DISCLAIMS ALL WARRANTIES, EXPRESS OR IMPLIED, INCLUDING, WITHOUT LIMITATION, ANY IMPLIED WARRANTIES OF MERCHANTABILITY, FITNESS FOR A PARTICULAR PURPOSE, OR NON-INFRINGEMENT OF THIRD PARTY INTELLECTUAL PROPERTY RIGHTS.

These resources are intended for developers skilled in the art designing with Renesas products. You are solely responsible for (1) selecting the appropriate products for your application, (2) designing, validating, and testing your application, and (3) ensuring your application meets applicable standards, and any other safety, security, or other requirements. These resources are subject to change without notice. Renesas grants you permission to use these resources only for development of an application that uses Renesas products. Other reproduction or use of these resources is strictly prohibited. No license is granted to any other Renesas intellectual property or to any third party intellectual property. Renesas disclaims responsibility for, and you will fully indemnify Renesas and its representatives against, any claims, damages, costs, losses, or liabilities arising out of your use of these resources. Renesas' products are provided only subject to Renesas' Terms and Conditions of Sale or other applicable terms agreed to in writing. No use of any Renesas resources expands or otherwise alters any applicable warranties or warranty disclaimers for these products.

(Rev.1.0 Mar 2020)

### Corporate Headquarters

TOYOSU FORESIA, 3-2-24 Toyosu,  
Koto-ku, Tokyo 135-0061, Japan  
[www.renesas.com](http://www.renesas.com)

### Contact Information

For further information on a product, technology, the most up-to-date version of a document, or your nearest sales office, please visit:  
[www.renesas.com/contact/](http://www.renesas.com/contact/)

### Trademarks

Renesas and the Renesas logo are trademarks of Renesas Electronics Corporation. All trademarks and registered trademarks are the property of their respective owners.