

MLX90632 FIR sensor

Datasheet

Features and Benefits

- Small size
- Easy to integrate
- Factory calibrated
- External ambient and object temperature calculation
- Measurement resolution of 0.02°C
- Supply voltage of 3.3V, supply current 1mA (sleep current less than 2.5uA)
- I²C compatible digital interface
- Software definable I²C address with 1 LSB bit external address pin
- Field of View of 50°
- Default refresh rate 0.5s, configurable between 16ms and 2s
- Integrated post-calibration option

Application Examples

- Non-contact temperature measurements
- Temperature sensing element for residential, commercial and industrial building air conditioning
- Industrial temperature control of moving parts
- Home appliances with temperature control



Figure 1: Image of MLX90632

MLX90632 FIR sensor

Datasheet

Description

The MLX90632 is a non-contact infrared temperature sensor in a small SMD SFN package. The device is factory calibrated with calibration constants stored in the EEPROM memory. The ambient and object temperature can be calculated based on these calibration constants and the measurement data.

The MLX90632 is factory calibrated in the ambient temperature range from -20 to 85°C and from -20 to 200°C for the object temperature range. The measured value is the average temperature of all objects in the Field Of View of the sensor.

It is very important for the application designer to understand that these accuracies are guaranteed and achievable when the sensor is in thermal equilibrium and under isothermal conditions (no temperature differences across the sensor package).

The accuracy of the thermometer can be influenced by temperature differences in the package induced by causes like (among others): Hot electronics behind the sensor, heaters/coolers behind or beside the sensor or by a hot/cold object very close to the sensor that not only heats the sensing element in the thermometer but also the thermometer package.

A major strength of the MLX90632 is that the measured effect of these temperature differences around the sensor package is reduced to a minimum by the internal measurement algorithm.

In the same way, localized thermal variations -like turbulence in the air- will not generate thermal noise in the output signal of the thermopile.

However, some extreme cases will influence the sensor.

The typical supply voltage of the MLX90632 is 3.3V. The communication with the chip is done by I²C in fast mode plus (FM+). Through I²C the external microcontroller has access to the following blocks:

- RAM memory used for measurement data
- EEPROM used to store the trimming values, calibration constants and device/measurement settings
- Register to control the sensor

Based on this data, the external microcontroller can calculate the object temperature and if needed the sensor temperature.

An optical filter (long-wave pass) that cuts off the visible and near infrared radiant flux is integrated in the sensor to provide ambient light immunity. The wavelength pass band of this optical filter is from 2 till 14µm.

Contents

Features and Benefits.....	1
Application Examples	1
Description.....	2
2. Ordering Information	5
3. Glossary of Terms.....	6
4. Absolute Maximum ratings.....	7
5. Pin definitions and descriptions.....	8
6. Electrical characteristics	9
7. Product Description.....	10
7.1. Block diagram.....	10
7.2. Description	10
8. Memory map.....	11
9. Control and configuration registers	13
9.1. REG_CONTROL.....	13
9.2. REG_STATUS	14
10. I ² C commands	15
10.1. Addressed read	16
10.2. Addressed write	16
10.3. Global reset.....	17
10.4. Addressed reset	17
10.5. EEPROM unlock for customer access	17
10.6. Direct read	18
11. Operating Modes.....	19
12. Temperature calculation	20
12.1. Pre-calculations.....	21
12.1.1. Ambient.....	21
12.1.2. Object	21
12.2. Ambient temperature	22
12.3. Object temperature.....	22
12.4. Example Temperature Calculation	23
12.4.1. Ambient temperature calculation	24

12.4.2. Object temperature calculation.....	25
13. Performance characteristics	27
13.1. Accuracy	27
13.2. Field of View (FoV).....	28
14. Mechanical Drawing	29
14.1. Package dimensions	29
14.2. PCB footprint.....	30
15. Application schematic.....	31
16. Standard information regarding manufacturability of Melexis products with different soldering processes.....	32
17. ESD Precautions.....	33
18. FAQ	33
19. Table of figures.....	34
20. Disclaimer.....	34
21. Contact Information	35

2. Ordering Information

Product	Temperature Code	Package	Option Code	Packing Form
MLX90632	S	LD	BCB-000	RE/SP

Table 1 : Ordering codes for MLX90632

Legend:

Temperature Code:	S: from -20°C to 85°C sensor temperature
Package Code:	“LD” for SFN 3x3 package
Option Code:	XYZ-123 X: Accuracy <ul style="list-style-type: none"> ▪ B: standard accuracy Y: Pixel type <ul style="list-style-type: none"> ▪ C: high stability version Z: Field Of View <ul style="list-style-type: none"> ▪ B: 50 degrees 1: I ² C level <ul style="list-style-type: none"> ▪ 0: 3V3 2-3: <ul style="list-style-type: none"> ▪ 00: Standard configuration ▪ xx: Reserved
Packing Form:	“RE” for Reel “SP” for sampling quantities in tubes
Ordering Example:	“MLX90632SLD-BCB-000-RE” For a non-contact thermometer in SFN 3x3 package with standard accuracy and a Field Of View of 50 degrees, delivered in Reel.

Table 2: Coding legend

3. Glossary of Terms

POR	Power On Reset
IR	InfraRed
I ² C	Inter-Integrated Circuit
SDA	Serial DA ta – I ² C compatible communication pins
SCL	Serial CL ock – I ² C compatible communication pins
ACK / NACK	Acknowledge / Not Acknowledge
SOC	Start Of Conversion
EOC	End Of Conversion
FOV	Field Of View
Ta	Ambient Temperature measured from the chip – (the package temperature)
To	Object Temperature , ‘seen’ from IR sensor
SFN	Single Flat pack No-lead
TBD	To Be Defined
LSB	Least Significant Bit
MSB	Most Significant Bit
EMC	Electro-Magnetic Compatibility
ESD	Electro-Static Discharge
HBM	Human Body Model
CDM	Charged Device Model

Table 3: List of abbreviations

4. Absolute Maximum ratings

Parameter	Symbol	Min.	Max.	Unit
Supply Voltage, (over voltage)	V_{DD}		5	V
Supply Voltage, (operating)	V_{DD}		3.6	V
Reverse Voltage	V_R		-1.5	V
Address-pin Voltage	V_{ADDR}		$V_{DD} + 0.6$	V
Operating Temperature Range	T_A	-20	+85	°C
Storage Temperature Range	T_S	-40	+105	°C
ESD Sensitivity (AEC Q100 002)				
- HBM			2	kV
- CDM			750	V
- Air discharge			+4	kV
- Contact discharge			+2	kV
DC current into SCL			10	μA
DC sink current, SDA pin		20		mA
DC clamp current, SDA pin			25	mA
DC clamp current, SCL pin			25	mA

Table 4: Absolute maximum ratings

Exceeding the absolute maximum ratings may cause permanent damage. Exposure to absolute maximum-rated conditions for extended periods may affect device reliability.

5. Pin definitions and descriptions

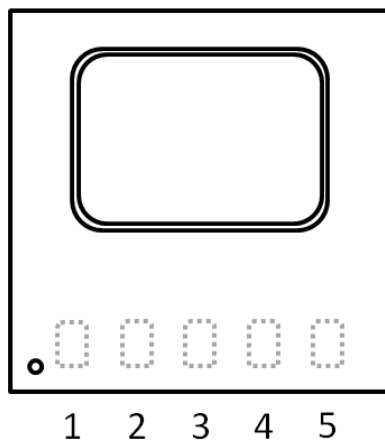

Figure 2: MLX90632 pinout, TOP view

Pin #	Name	Direction	Description
1	SDA	In/Out	I ² C Data line
2	VDD	POWER	Supply
3	GND	GND	Ground
4	SCL	In	I ² C Clock line
5	ADDR	In	LSB of I ² C address

Table 5: Pin definition

6. Electrical characteristics

All parameters are valid for $T_A = 25\text{ }^\circ\text{C}$, $V_{DD} = 3.3\text{V}$ (unless otherwise specified)

Parameter	Symbol	Test Conditions	Min	Typical	Max	Units
Supplies						
External supply	V_{DD}		3	3.3	3.6	V
Supply current	I_{DD}	No load	0.5	1	1.4	mA
Sleep current	I_{DDpr}	No load, erase/write EEPROM operations		1.5	2.5	μA
Power On Reset						
POR level	$V_{POR\ up}$	Power-up (full temp range)	1.3		2.4	V
POR level	$V_{POR\ down}$	Power-down (full temp range)	1.1		2.1	V
POR hysteresis	$V_{POR\ hys}$	Full temperature range	200		500	mV
V_{DD} rise time (10% to 90% of specified supply voltage)	T_{POR}	Ensure POR signal			20	ms
Output valid (result in RAM)	T_{valid}	After POR	64			ms
I²C compatible 2-wire interface						
I ² C Voltage	V_{I2C}		3	V_{DD}	3.6	V
Input high voltage	V_{IH}	Over temperature and supply	$0.7 \cdot V_{I2C}$		$V_{I2C} + 0.5$	V
Input low voltage	V_{IL}	Over temperature and supply	-0.5		$0.3 \cdot V_{I2C}$	V
Output low voltage	V_{OL}	Over temperature and supply	0		0.4	V
Address pin voltage ("1")	$V_{ADDR,HI}$		2	V_{DD}	$V_{DD} + 0.5$	V
Address pin voltage ("0")	$V_{ADDR,LO}$		0		0.5	V
ADDR leakage	$I_{ADDR, leak}$				1	μA
SCL leakage	$I_{SCL, leak}$	$V_{SCL} = 3.6\text{V}$, $T_a = +85^\circ\text{C}$			1	μA
SDA leakage	$I_{SDA, leak}$	$V_{SDA} = 3.6\text{V}$, $T_a = +85^\circ\text{C}$			1	μA
SCL capacitance	C_{SCL}				10	pF
SDA capacitance	C_{SDA}				10	pF
Slave address	SA	Factory default, ADDR-pin grounded		3A		hex

Table 6: Electrical characteristics

7. Product Description

7.1. Block diagram

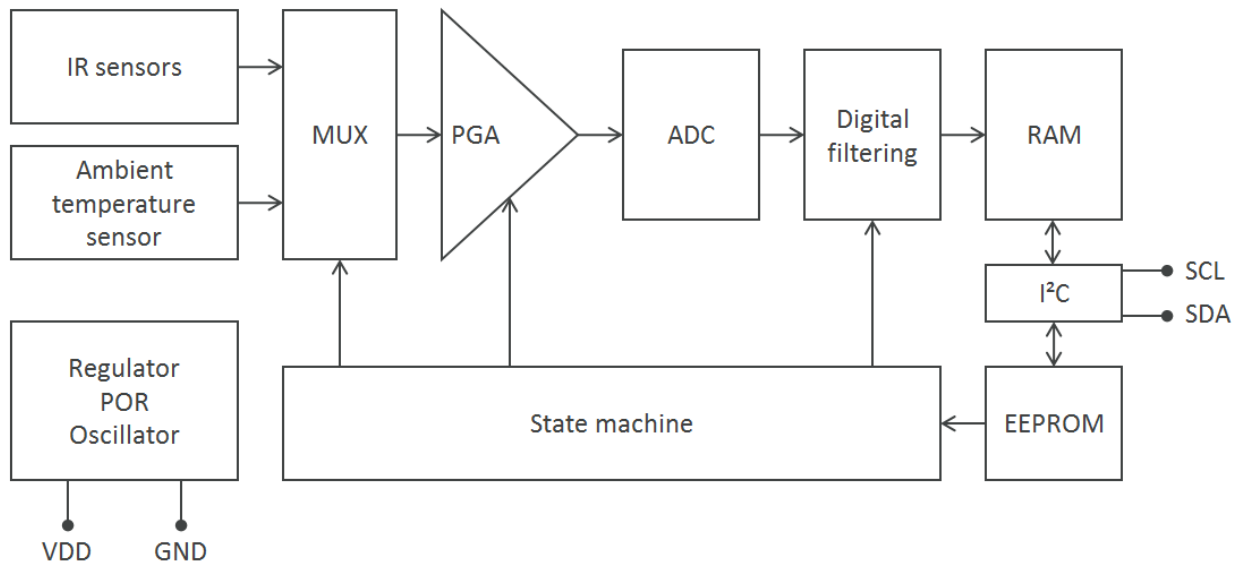

Figure 3: Block diagram

7.2. Description

The MLX90632 is a far infrared, non-contact temperature sensor which is factory calibrated to a high accuracy. Internally, electrical and thermal precautions are taken to compensate for thermally harsh external conditions. The thermopile sensing element voltage signal is amplified and digitized. After digital filtering, the raw measurement result is stored in the RAM memory. Furthermore, the MLX90632 contains a sensor element to measure the temperature of the sensor itself. The raw information of this sensor is also stored in RAM after processing. All above functions are controlled by a state machine. The result of each measurement conversion is accessible via I²C.

The communication to the chip is done by I²C in fast mode plus (FM+). The requirement of the standard is to run at frequencies up to 1MHz. Through I²C the external unit can have access to the following blocks:

- Control registers of internal state machines
- RAM (96bit x 16bit) for pixel and auxiliary measurement data, in this document mainly referred to as 'storage memory'.
- EEPROM (256bit x 16bit) used to store the trimming values, calibration constants and various device/measurement settings.

From the measurement data and the calibration data the external unit can calculate both the sensor temperature and the object temperature. The calculation allows the customer to adjust the calibration for his own application in case an optical window or obstructions are present.

8. Memory map

Access (Write key required)	Address	Name	Description
EEPROM			
Read-only	0x240B	EE_VERSION	EEPROM version
Read-only	0x240C	EE_P_R [15:0]	P_R calibration constant (16-bit, Least Significant Word)
Read-only	0x240D	EE_P_R [31:16]	P_R calibration constant (16-bit, Most Significant Word)
Read-only	0x240E	EE_P_G [15:0]	P_G calibration constant (16-bit, Least Significant Word)
Read-only	0x240F	EE_P_G [31:16]	P_G calibration constant (16-bit, Most Significant Word)
Read-only	0x2410	EE_P_T [15:0]	P_T calibration constant (16-bit, Least Significant Word)
Read-only	0x2411	EE_P_T [31:16]	P_T calibration constant (16-bit, Most Significant Word)
Read-only	0x2412	EE_P_O [15:0]	P_O calibration constant (16-bit, Least Significant Word)
Read-only	0x2413	EE_P_O [31:16]	P_O calibration constant (16-bit, Most Significant Word)
Read-only	0x2414	EE_Aa [15:0]	Aa calibration constant (16-bit, Least Significant Word)
Read-only	0x2415	EE_Aa [31:16]	Aa calibration constant (16-bit, Most Significant Word)
Read-only	0x2416	EE_Ab [15:0]	Ab calibration constant (16-bit, Least Significant Word)
Read-only	0x2417	EE_Ab [31:16]	Ab calibration constant (16-bit, Most Significant Word)
Read-only	0x2418	EE_Ba [15:0]	Ba calibration constant (16-bit, Least Significant Word)
Read-only	0x2419	EE_Ba [31:16]	Ba calibration constant (16-bit, Most Significant Word)
Read-only	0x241A	EE_Bb [15:0]	Bb calibration constant (16-bit, Least Significant Word)
Read-only	0x241B	EE_Bb [31:16]	Bb calibration constant (16-bit, Most Significant Word)
Read-only	0x241C	EE_Ca [15:0]	Ca calibration constant (16-bit, Least Significant Word)
Read-only	0x241D	EE_Ca [31:16]	Ca calibration constant (16-bit, Most Significant Word)
Read-only	0x241E	EE_Cb [15:0]	Cb calibration constant (16-bit, Least Significant Word)
Read-only	0x241F	EE_Cb [31:16]	Cb calibration constant (16-bit, Most Significant Word)
Read-only	0x2420	EE_Da [15:0]	Da calibration constant (16-bit, Least Significant Word)
Read-only	0x2421	EE_Da [31:16]	Da calibration constant (16-bit, Most Significant Word)
Read-only	0x2422	EE_Db [15:0]	Db calibration constant (16-bit, Least Significant Word)
Read-only	0x2423	EE_Db [31:16]	Db calibration constant (16-bit, Most Significant Word)
Read-only	0x2424	EE_Ea [15:0]	Ea calibration constant (16-bit, Least Significant Word)
Read-only	0x2425	EE_Ea [31:16]	Ea calibration constant (16-bit, Most Significant Word)
Read-only	0x2426	EE_Eb [15:0]	Eb calibration constant (16-bit, Least Significant Word)
Read-only	0x2427	EE_Eb [31:16]	Eb calibration constant (16-bit, Most Significant Word)
Read-only	0x2428	EE_Fa [15:0]	Fa calibration constant (16-bit, Least Significant Word)

Read-only	0x2429	EE_Fa [31:16]	Fa calibration constant (16-bit, Most Significant Word)
Read-only	0x242A	EE_Fb [15:0]	Fb calibration constant (16-bit, Least Significant Word)
Read-only	0x242B	EE_Fb [31:16]	Fb calibration constant (16-bit, Most Significant Word)
Read-only	0x242C	EE_Ga [15:0]	Ga calibration constant (16-bit, Least Significant Word)
Read-only	0x242D	EE_Ga [31:16]	Ga calibration constant (16-bit, Most Significant Word)
Read-only	0x242E	EE_Gb [15:0]	Gb calibration constant (16-bit)
Read-only	0x242F	EE_Ka [15:0]	Ka calibration constant (16-bit)
Read-only	0x2430	EE_Kb [15:0]	Kb calibration constant (16-bit)
-	-	Melexis reserved	
Y	0x2481	EE_Ha [15:0]	Ha Customer calibration constant (16 bit)
Y	0x2482	EE_Hb [15:0]	Hb Customer calibration constant (16 bit)
-	-	Melexis reserved	
Y	0x24D4	EE_CONTROL	EEPROM Control register, measurement control
Y	0x24D5	EE_I2C_ADDRESS	I ² C slave address >> 1 <u>Example:</u> standard address (= 0x003A) >> 1 = 0x001D
REGISTER			
N	0x3000	REG_I2C_ADDRESS	I ² C slave address >> 1
N	0x3001	REG_CONTROL	Control register, measurement mode
-	-	Melexis reserved	
N	0x3FFF	REG_STATUS	Status register: data available
RAM			
N	0x4000	RAM_1	Raw data 1
N	0x4001	RAM_2	Raw data 2
N	0x4002	RAM_3	Raw data 3
N	0x4003	RAM_4	Raw data 4
N	0x4004	RAM_5	Raw data 5
N	0x4005	RAM_6	Raw data 6
N	0x4006	RAM_7	Raw data 7
N	0x4007	RAM_8	Raw data 8
N	0x4008	RAM_9	Raw data 9

Table 7: Memory table

Important!

The width of the EEPROM is 16 bit.

Some calibration parameters are 32 bit and split up into two 16 bit numbers in EEPROM.

The least significant 16 bits of the parameter starts on the address shown in the Memory table.

Example: To retrieve value EE_Aa (32bit) = EE_Aa_MS (at 0x2415) << 16 | EE_Aa_LS (at 0x2414)

9. Control and configuration registers

Several registers are available to control and configure the measurements:

9.1. REG_CONTROL

REG_CONTROL controls the measurement handling and data storage.

Bits	Parameter	Description	See section
15:12	MLX internal		
10	MLX internal		
9	MLX internal		
8:4	MLX internal		
3	soc	starts a measurement when being in (sleeping) step mode	0
2:1	mode[1:0]	defines the operating mode (step mode or continuous mode)	0
0	MLX internal		

Table 8: REG_CONTROL register

Note that this register is initialized during POR by the EEPROM word EE_CONTROL.

Several measurement modes exist. These modes are controlled by bits mode[1:0] in register REG_CONTROL. In continuous mode the measurements are constantly running while in step mode the state machine will execute only one measurement which is initiated by soc bit. After finishing the measurement it will go in wait state until the next measurement is initiated by soc. The measurements are following the measurement sequence as defined in the measurement table.

The different possible measurement modes are:

- mode[1:0] = 01: Enables the sleeping step mode. In this mode the device will be by default in sleep. On request (soc bit), the device will power-on, the state machine will do one measurement, will go into sleep and will wait for next command.
- mode[1:0] = 10: Enables the step mode. In this mode the state machine will do one measurement upon request (soc bit) and will wait for next command. The device remains powered all time in this mode.
- mode[1:0] = 11: Device is in continuous mode. Measurements are executed continuously. The device remains powered all time in this mode.

Switching between the step modes and continuous mode has only effect after the current measurement has finished (not waiting till end of measurement table was reached).

9.2. REG_STATUS

REG_STATUS allows checking in which state the device is and indicates when measurements are finished.

Bits	Parameter	Description	See section
10	device_busy	Read-only Flag indicating that a measurement is being executed (1: measurement ongoing) In sleep mode, this flag is always low. In continuous mode, this flag is always high. In step mode, this flag is high during one measurement.	
9	eeeprom_busy	Read-only Flag indicating that the eeprom is busy (0: not busy) Eeprom being busy is defined as follows: - at start-up, the eeprom is busy and remains busy till initialization phase (eeprom copy) has finished - during eeprom write/erase, the eeprom is busy	
8	brown_out	Bit is set to 0 Customer should set bit to 1 When device is reset, the bit is set to 0 and reset can be detected	
6:2	cycle_pos	Read-only Cycle_pos returns the current position of the measurement defined by the measurement table (number from 0 to 31)	
0	new_data	Customer should set bit to 0 When a measurement is done, the bit is set to 1 Customer can readout the data and reset the bit to 0	11

Table 9: REG_STATUS register

10. I²C commands

This device is based on I²C specification Rev.5 – October 9th 2012. I²C FM+ mode is supported.

The sensor implements following I²C features:

- Slave mode only
- 7-bits addressing
- Modes: Standard-mode, Fast-mode, Fast-mode Plus
- Incremental addressing – allowing a block of addresses to be accessed inside one I²C sequence

As a standard, the device responds to the 7-bit slave address: 0x3A.

The least significant bit of the address is determined by the status of the ADDR-pin (either connected to ground or supply) and is taken in after power-up or reset command if the change is made in EEPROM.



Part that is written in EEPROM
 = 0x1D



7-bit slave address
 = 0x3A if ADDR-pin is pulled low
 = 0x3B if ADDR-pin is pulled high

Important! The device will not respond if the I²C address is changed to 0 (and ADDR pin is low). The only way to get the device to respond is to pull the ADDR pin high. The slave address will be changed to 1 and communication is possible.

The following I²C commands are implemented:

- Read/write access to internal memories and registers
 - ❑ Addressed write
 - ❑ Addressed read
- Global reset / addressed reset
- EEPROM unlock for CUST access

Important! The device shall not execute measurements when performing EEPROM memory operations (I²C read/write instructions in EEPROM address range)! Hence, the device shall be put in halt mode or in a stepping mode before doing EEPROM read/write operations.

10.1. Addressed read

The addressed read command allows doing an incremental read-out, starting from any given address within the memory space.

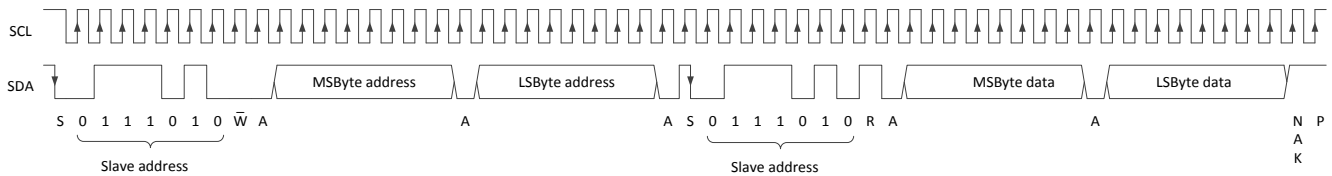

Figure 4: Addressed read

Important!

An addressed read is only valid when combining directly an addressed write and a direct read through a repeated START condition. In case the read and write part are separated by a STOP condition, or in case the read is not directly following the write, or in case the slave address is not identical for both, the command will not be seen as an addressed read. As a result, the second read will in practice act as a direct read.

As soon as incremental addressing leaves the address space, the slave will respond with all 8'hFF.

10.2. Addressed write

The addressed write command allows doing an incremental write, starting from any given address within the memory space.

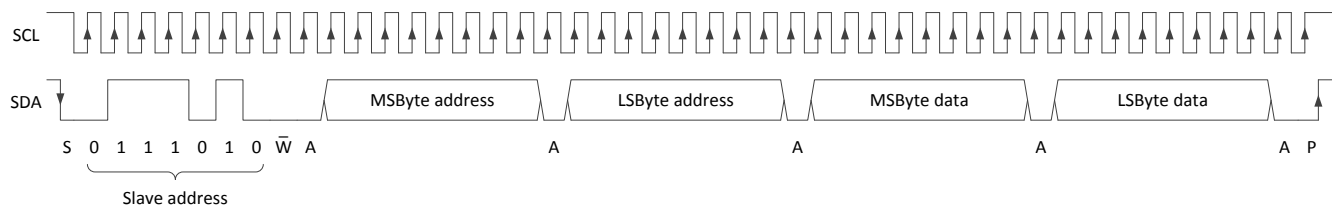

Figure 5: Addressed write

Important!

The slave is sending ACK/NACK based on the fact whether it was able to write data (timing, end of register space, access rights).

The slave will automatically increment the address of the write byte, independent if it gave an ACK or a NACK to the master. It is up to the master to re-write the byte afterwards.

Before writing to EEPROM it is necessary to erase the specific address location in EEPROM. This is done by first writing 0x0000. Then the new data can be written.

When the device is busy with the write operation to EEPROM, new write commands will be ignored. A read operation will return invalid data. The fact that the device is busy is indicated via the bit `device_busy` in `REG_STATUS`.

10.3. Global reset

This command resets all devices on the I²C bus (based on the general call address 0x00).

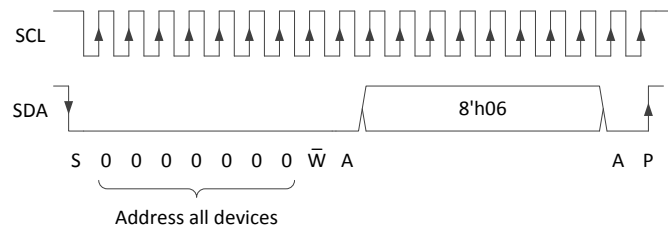

Figure 6: Global reset

10.4. Addressed reset

This command resets the addressed device only (based on the I²C address).

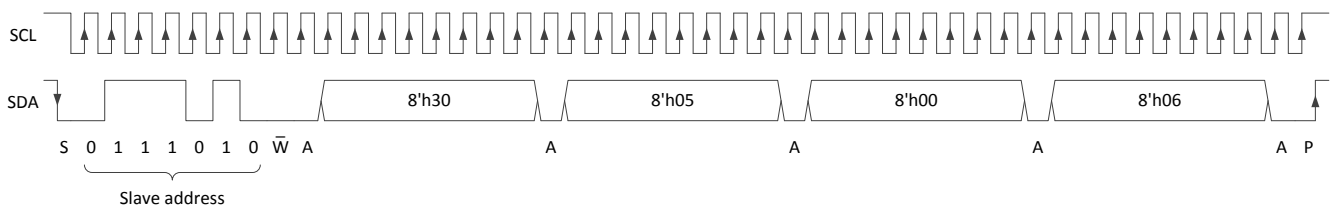

Figure 7: Addressed reset

10.5. EEPROM unlock for customer access

This command unlocks the EEPROM allowing only one write operation to an EEPROM word in the customer part of the EEPROM.

After the EEPROM write, the EEPROM access goes back to the “NoKey” access mode.

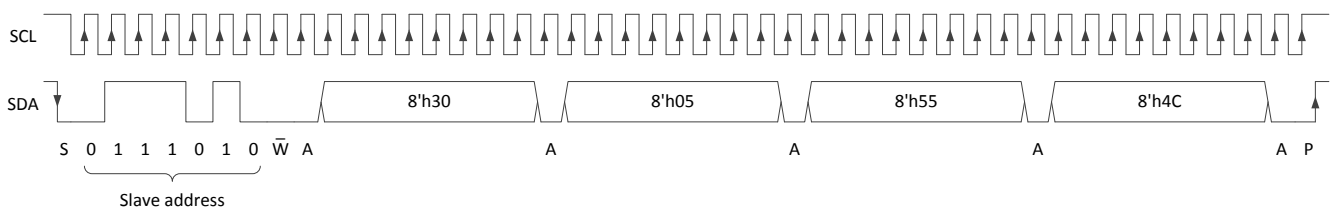

Figure 8: EEPROM unlock

10.6. Direct read

The direct read command allows an incremental read out at a default start address.

This default start address is fixed to the register location REG_STATUS (0x3FFF).

According to the I²C specification, the master will keep sending an acknowledge (A) until it want to stop. This is indicated by sending a NACK. As a result, the slave will stop driving the SDA-bus as soon as a NACK is received by the master.

As soon as the incremental addressing leaves the address space, the slave will respond with all 8'hFF.

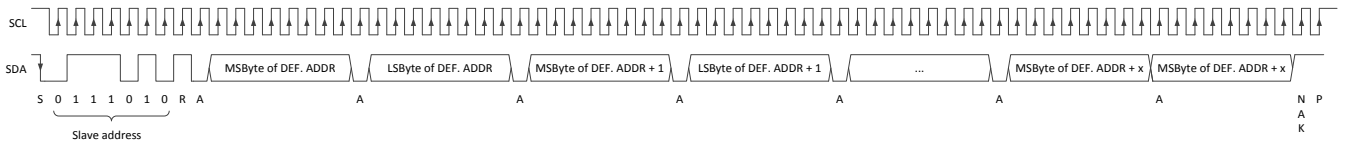

Figure 9: Direct read

11. Operating Modes

The device has two states of operation: **sleep state** and **active state**.

- **Sleep state**

In this state, most of the circuitry is disabled to limit the current consumption to a few μA .

- **Active state**

In this state, the sensor is active.

Several measurement modes exist. These modes are controlled by bits mode[1:0] in register REG_CONTROL[2:1]. In continuous mode the measurements are constantly running while in step mode the state machine will execute only one measurement which is initiated by soc bit. After finishing the measurement it will go in wait state until the next measurement is initiated by soc. The measurements are following the measurement sequence as defined in the measurement table.

The different possible measurement modes are:

- mode[1:0] = 01: Enables the sleeping step mode.

The device will be by default in sleep mode. On request (soc bit), the device will power-on, the state machine will do one measurement, will go into sleep and will wait for next command.

- mode[1:0] = 10: Enables the step mode.

The state machine will do one measurement upon request (soc bit) and will wait for next command. The device remains powered all time in this mode.

- mode[1:0] = 11: Device is in continuous mode.

Measurements are executed continuously. The device remains powered all time in this mode.

Switching between the step modes and continuous mode has only effect after the current measurement has finished (not waiting till end of measurement table was reached).

12. Temperature calculation

To calculate the ambient and object temperature, a set of 2 measurements is required:

- Measurement 1: RAM_4, RAM_5, RAM_6;
- Measurement 2: RAM_7, RAM_8, RAM_9;

One should notice this requires double the measurement time than specified (= 2 * 512ms). However, this is only valid for the very first calculation. After the first calculation, TA and TO should be calculated with the next measurement.

Example:

t0:	Measurement 1 (cycle_pos = 1)	=>	no calculation of TA or TO possible because not all parameters are known		
t1:	Measurement 2 (cycle_pos = 2)	=>	calculate TA (RAM_6, RAM_9) calculate TO (RAM_7, RAM_8, RAM_6, RAM_9)	=>	1 s.
t2:	Measurement 3 (= 1) (cycle_pos = 1)	=>	calculate TA (RAM_6, RAM_9) calculate TO (RAM_4, RAM_5, RAM_6, RAM_9)	=>	0.512 s.
t3:	Measurement 4 (= 2) (cycle_pos = 2)	=>	calculate TA (RAM_6, RAM_9) calculate TO (RAM_7, RAM_8, RAM_6, RAM_9)	=>	0.512 s.
t4:	...				

To calculate the new ambient and object temperature RAM_6 and RAM_9 have to be used. The choice between [RAM_4 and RAM_5] or [RAM_7 and RAM_8] depends on the current measurement. REG_STATUS[6:2] (= "cycle_pos") returns the current position of the measurement defined in the measurement table.

Using the current and the data from measurement (x-1), TA and TO can be calculated every 512ms.

The complete measurement sequence can be automated by using the new_data bit in combination with cycle_pos bits.

The sequence should look like the following:

- Write new_data = 0
- Check when new_data = 1
- Read cycle_pos to get measurement pointer
 - ❑ If cycle_pos = 1
 - Calculate TA and TO based on RAM_4, RAM_5, RAM_6, RAM_9
 - ❑ If cycle_pos = 2
 - Calculate TA and TO based on RAM_7, RAM_8, RAM_6, RAM_9
- Return to top

12.1. Pre-calculations

12.1.1. Ambient

$$VR_{TA} = RAM_9 + Gb * \frac{RAM_6}{12}$$

$$Gb = EE_Gb * 2^{-10}$$

$$AMB = \left[\frac{RAM_6}{12} \right] / VR_{TA} * 2^{19}$$

The parameter EE_Gb is a signed 16-bit number.

12.1.2. Object

$$S = \frac{RAM_4 + RAM_5}{2}$$

OR

$$S = \frac{RAM_7 + RAM_8}{2}$$

$$VR_{TO} = RAM_9 + Ka * \frac{RAM_6}{12}$$

$$Ka = EE_Ka * 2^{-10}$$

$$S_{TO} = \left[\frac{S}{12} \right] / VR_{TO} * 2^{19}$$

The parameter EE_Ka is a signed 16-bit number.

12.2. Ambient temperature

$$T_a \text{ (sensor temperature in } ^\circ\text{C)} = P_O + \frac{AMB - P_R}{P_G} + P_T * (AMB - P_R)^2$$

With:

Ta in degrees Celsius

$$\begin{aligned} P_R &= EE_P_R * 2^{-8} \\ P_O &= EE_P_O * 2^{-8} \\ P_G &= EE_P_G * 2^{-20} \\ P_T &= EE_P_T * 2^{-44} \end{aligned}$$

The parameters EE_P_R, EE_P_O, EE_P_G and EE_P_T are signed 32-bit numbers.

12.3. Object temperature

TO (object temperature in °C)

$$= \sqrt[4]{\frac{S_{TO}}{\varepsilon * Fa * Ha * (1 + Ga * (TO_{DUT} - TO_0) + Fb * (TA_{DUT} - TA_0))} + Ta_{[K]}^4} - 273.15 - Hb$$

With:

$$\begin{aligned} Fa &= EE_Fa * 2^{-46} \\ Fb &= EE_Fb * 2^{-36} \\ Ga &= EE_Ga * 2^{-36} \\ Ha &= EE_Ha * 2^{-14} \\ Hb &= EE_Hb * 2^{-14} \\ TO_0 &= 25^\circ\text{C} \\ TA_0 &= 25^\circ\text{C} \end{aligned}$$

$$TA_{DUT} = \frac{(AMB - Eb)}{Ea} + 25$$

$$\begin{aligned} Ea &= EE_Ea * 2^{-16} \\ Eb &= EE_Eb * 2^{-8} \end{aligned}$$

Ta_[K] = TA_{DUT} + 273.15 in Kelvin

TO_{DUT} = Object temperature in 25°C

ε = 1 = Object Emissivity parameter (not stored in EEPROM, but part of the 'app')

The parameters EE_Ea, EE_Eb, EE_Fa, EE_Fb, EE_Ga are signed 32-bit numbers.

The parameters EE_Gb, EE_Ka, EE_Ha and EE_Hb are signed 16-bit numbers.

Note:

One can see that to compute "To (object temperature)", "To" already needs to be known.

"To (object temperature)" is computed in an iterative manner. In the first iteration "To" is assumed to be 25°C.

In the 2nd iteration the result of first iteration is used, and in the 3rd iteration the end result is obtained.

(See example on next page).

12.4. Example Temperature Calculation

Assumed are the following calibration parameters read from EEPROM:

ADDR	PARAM	DATA (hex)	hex to dec	Conversion to use in formula
0x240C	EE_P_R [15:0]	0103	EE_P_R = 005D0103 _{hex} = 6095107 _{dec}	P_R = 6095107 * 2⁻⁸ = 23809.01
0x240D	EE_P_R [31:16]	005D		
0x240E	EE_P_G [15:0]	FAE5	EE_P_G = 051CFAE5 _{hex} = 85785317 _{dec}	P_G = 85785317 * 2⁻²⁰ = 81.81125
0x240F	EE_P_G [31:16]	051C		
0x2410	EE_P_T [15:0]	0000	EE_P_T = 00000000 _{hex} = 0 _{dec}	P_T = 0 * 2⁻⁴⁴ = 0
0x2411	EE_P_T [31:16]	0000		
0x2412	EE_P_O [15:0]	1900	EE_P_O = 00001900 _{hex} = 6400 _{dec}	P_O = 6400 * 2⁻⁸ = 25
0x2413	EE_P_O [31:16]	0000		
0x2424	EE_Ea [15:0]	CFAE	EE_Ea = 0051CFAE _{hex} = 5361582 _{dec}	Ea = 5361582 * 2⁻¹⁶ = 81.81125
0x2425	EE_Ea [31:16]	0051		
0x2426	EE_Eb [15:0]	0103	EE_Eb = 005D0103 _{hex} = 6095107 _{dec}	Eb = 6095107 * 2⁻⁸ = 23809.01
0x2427	EE_Eb [31:16]	005D		
0x2428	EE_Fa [15:0]	6351	EE_Fa = 03506351 _{hex} = 5559995 _{dec}	Fa = 55599953 * 2⁻⁴⁶ = 7.9E-07
0x2429	EE_Fa [31:16]	0350		
0x242A	EE_Fb [15:0]	71F1	EE_Fb = FE2571F1 _{hex} = -31100431 _{dec}	Fb = -31100431 * 2⁻³⁶ = -0.00045
0x242B	EE_Fb [31:16]	FE25		
0x242C	EE_Ga [15:0]	A7A4	EE_Ga = FDFFA7A5 _{hex} = -33577052 _{dec}	Ga = -33577052 * 2⁻³⁶ = -0.00049
0x242D	EE_Ga [31:16]	FDFF		
0x242E	EE_Gb [15:0]	2600	EE_Gb = 2600 _{hex} = 9728 _{dec}	Gb = 9728 * 2⁻¹⁰ = 9.5
0x242F	EE_Ka [15:0]	2A00	EE_Ka = 2A00 _{hex} = 10752 _{dec}	Ka = 10752 * 2⁻¹⁰ = 10.5
0x2481	EE_Ha [15:0]	4000	EE_Ha = 4000 _{hex} = 16384 _{dec}	Ha = 16384 * 2⁻¹⁴ = 1
0x2482	EE_Hb [15:0]	0000	EE_Hb = 0000 _{hex} = 0 _{dec}	Hb = 0 * 2⁻¹⁴ = 0

The returned values from the RAM (0x4000 to 0x4008):

ADDR	PARAM	DATA (hex)	DATA (dec)
0x4003	RAM_4	FF9B	-101
0x4004	RAM_5	FF9D	-99
0x4005	RAM_6	57E4	22500
0x4006	RAM_7	FF97	-105
0x4007	RAM_8	FF99	-103
0x4008	RAM_9	59D8	23000

12.4.1. Ambient temperature calculation

$$VR_{TA} = RAM_9 + Gb * \frac{RAM_6}{12} = 23000 + 9.5 * \frac{22500}{12}$$

$$VR_{TA} = 40812.5$$

$$AMB = \left[\frac{RAM_6}{12} \right] / VR_{TA} * 2^{19} = \left[\frac{22500}{12} \right] / 40812.5 * 2^{19}$$

$$AMB = 24086.73813$$

$$Ta \text{ (sensor temperature in } ^\circ\text{C)} = P_O + \frac{AMB - P_R}{P_G} + P_T * (AMB - P_R)^2$$

$$Ta = 25 + \frac{24086.73813 - 23809.01}{81.81125} + 0 * (24086.73813 - 23809.01)^2$$

$$Ta = 28.395^\circ\text{C}$$

$$Ta = \mathbf{28.4^\circ\text{C}}$$

12.4.2. Object temperature calculation

$$S = \frac{RAM_4 + RAM_5}{2} = \frac{(-101) + (-99)}{2}$$

$$S = -100$$

OR

$$S = \frac{RAM_7 + RAM_8}{2} = \frac{(-105) + (-103)}{2}$$

$$S = -104$$

Assumed is that RAM_4 and RAM_5 are updated lastly by the device (cycle_pos = 1)

$$VR_{TO} = RAM_9 + Ka * \frac{RAM_6}{12} = 23000 + 10.5 * \frac{22500}{12}$$

$$VR_{TO} = 42687.5$$

$$S_{TO} = \left[\frac{S}{12} \right] / VR_{TO} * 2^{19} = \left[\frac{-100}{12} \right] / 42687.5 * 2^{19}$$

$$S_{TO} = -102.35$$

$$TO_0 = 25^{\circ}\text{C}$$

$$TA_0 = 25^{\circ}\text{C}$$

$$TA_{DUT} = \frac{(AMB - Eb)}{Ea} + 25 = \frac{(24086.73813 - 23809.01)}{81.81125} + 25 = 28.3947$$

$$Ta_{[K]} = TA_{DUT} + 273.15 = 28.3947 + 273.15 = 301.5447$$

To (object temperature in °C)

$$= \sqrt[4]{\frac{S_{TO}}{\epsilon * Fa * Ha * (1 + Ga * (T_{O_{DUT}} - T_{O_0}) + Fb * (T_{A_{DUT}} - T_{A_0}))}} + T_{a[K]}^4 - 273.15 - Hb$$

The emissivity parameter (ε) is controlled by the user and is assumed in this example equal to 1.

T_{O_{DUT}} = 25 for the first calculation

$$T_o = \sqrt[4]{\frac{-102.35}{1 * (7.9E - 07) * 1 * (1 + (-0.00049) * (25 - 25) + (-0.00045) * (28.3947 - 25))}} + (301.5447)^4 - 273.15 - 0$$

To = 27.2048027°C

The object temperature needs to be calculated 3 times in order to get the end result.

Next object temperature calculation uses previous obtained object temperature.

To

$$= \sqrt[4]{\frac{-102.35}{1 * (7.9E - 07) * 1 * (1 + (-0.00049) * (27.2048027 - 25) + (-0.00045) * (28.3947 - 25))}} + (301.5447)^4 - 273.15 - 0$$

To = 27.2035098°C

To

$$= \sqrt[4]{\frac{-102.35}{1 * (7.9E - 07) * 1 * (1 + (-0.00049) * (27.2035098 - 25) + (-0.00045) * (28.3947 - 25))}} + (301.5447)^4 - 273.15 - 0$$

To = 27.20351053°C

To = 27.2°C

13. Performance characteristics

13.1. Accuracy

The MLX90632 is factory calibrated in the temperature range of -20...85°C for the ambient temperature and -20...200°C for the object temperature. The measured value is the average temperature of all objects in the Field Of View of the sensor. The accuracy of the MLX90632 is $\pm 1^\circ\text{C}$ within the object temperature range of 0 to 50°C for consumer applications.

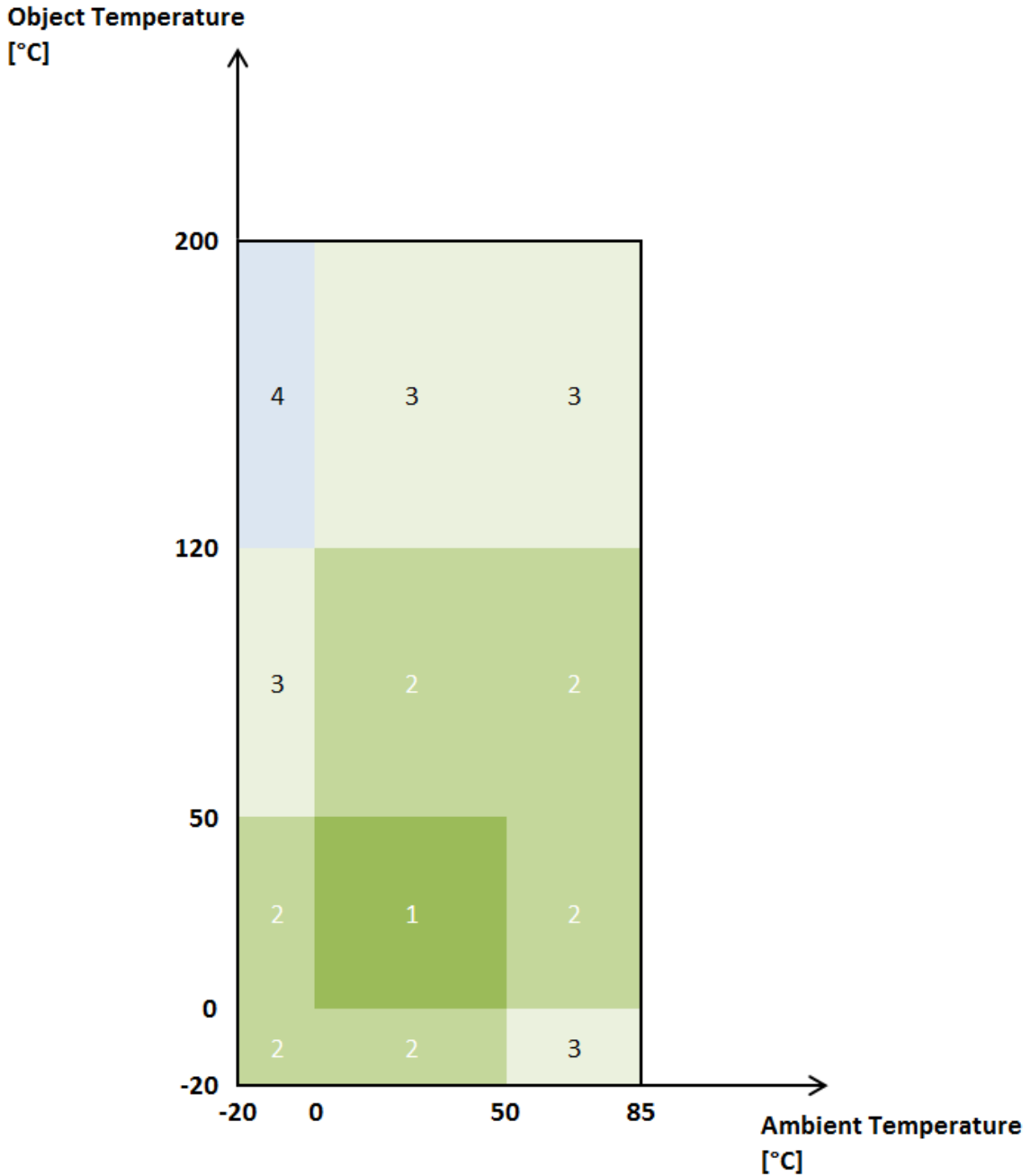

Figure 10 : Accuracy table for VDD = 3.3V

All accuracy specifications apply under settled isothermal conditions only.

13.2. Field of View (FoV)

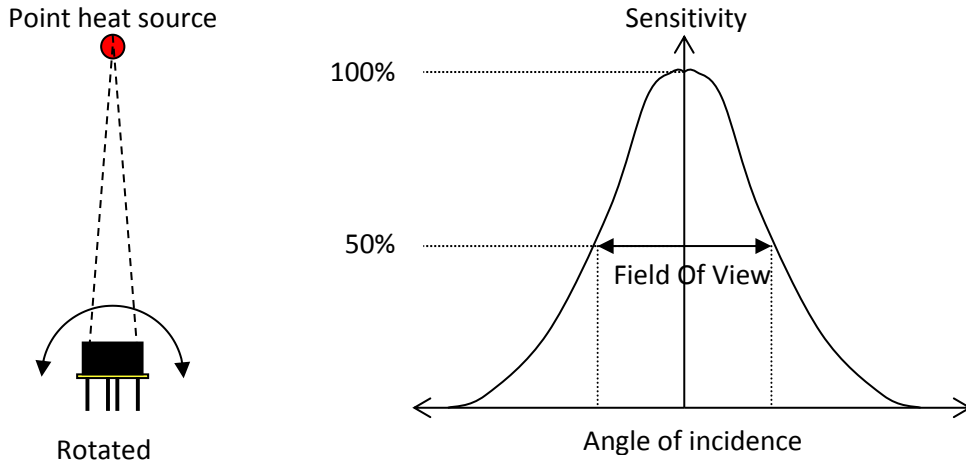

Figure 11: Field of View measurement principle

Parameter	50% of maximum	10% of maximum	Unit
Field Of View	50	70	° (angular degrees)

Table 10 : Field Of View of the MLX90632

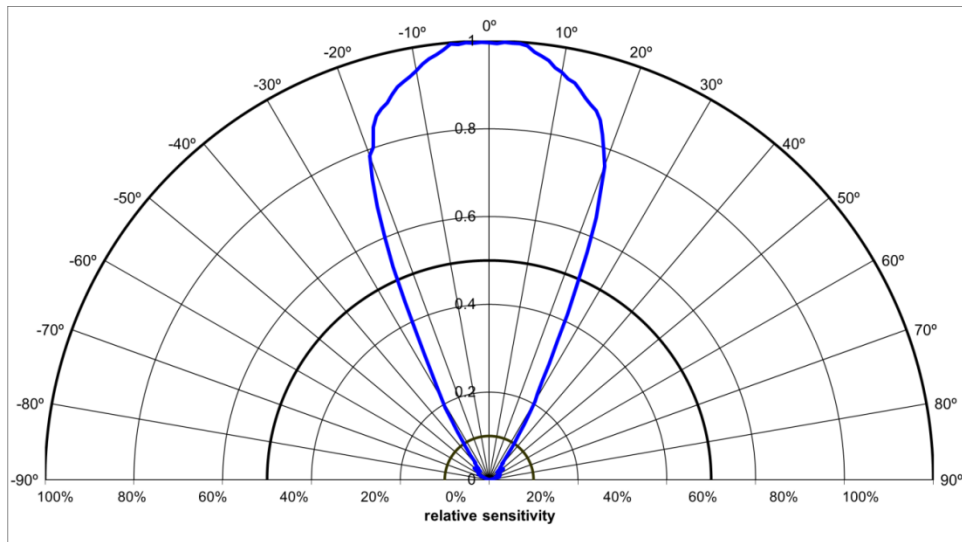

Figure 12: Field of View of MLX90632

14. Mechanical Drawing

14.1. Package dimensions

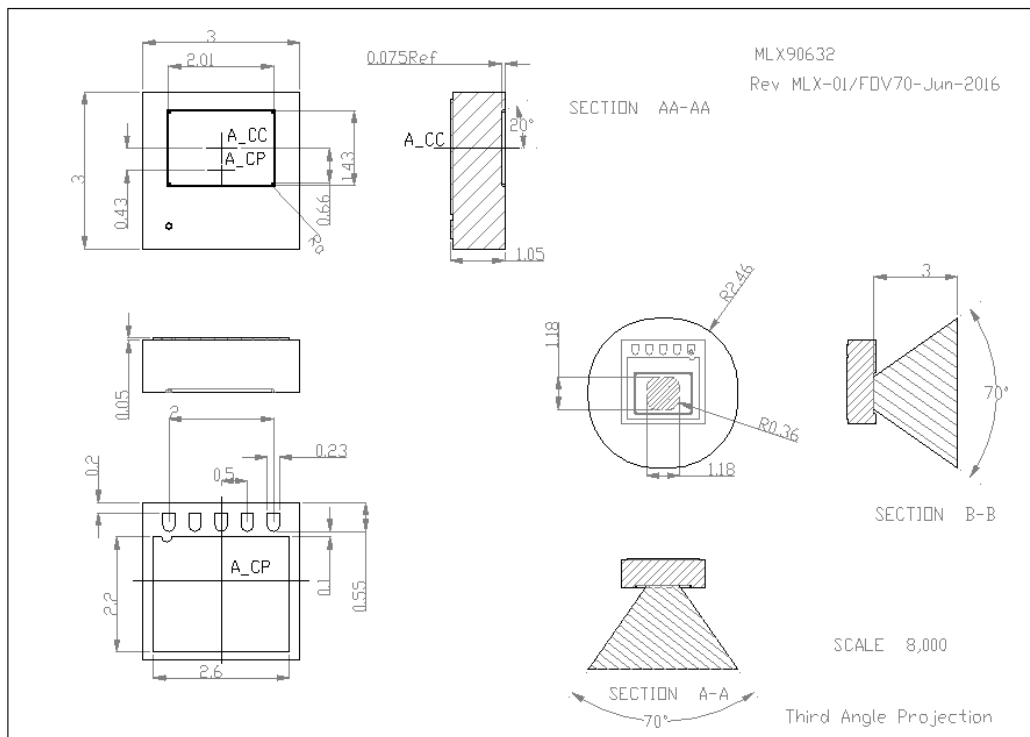

Figure 13: Package dimensions for MLX90632 (FoV = 50°)

Symbol	Min	Nom	Max
DD	3.00 BSC		
EE	3.00 BSC		
AT	0.90	0.95	1.00
Ab1	0.00	0.02	0.05
Ra	0.05		
D2	2.40	2.50	2.60
E2	2.00	2.10	2.20
Lo1	0.15 Max		
Kk	0.20	--	--
NXL	0.35	0.40	0.45
e1	0.50 BSC		
NminOne_e	(5-1)*e1		
Ti	0.18	0.25	0.30

Table 11: Package dimensions for MLX90632 (FoV = 50°)

*BSC ≡ basic dimension

14.2. PCB footprint

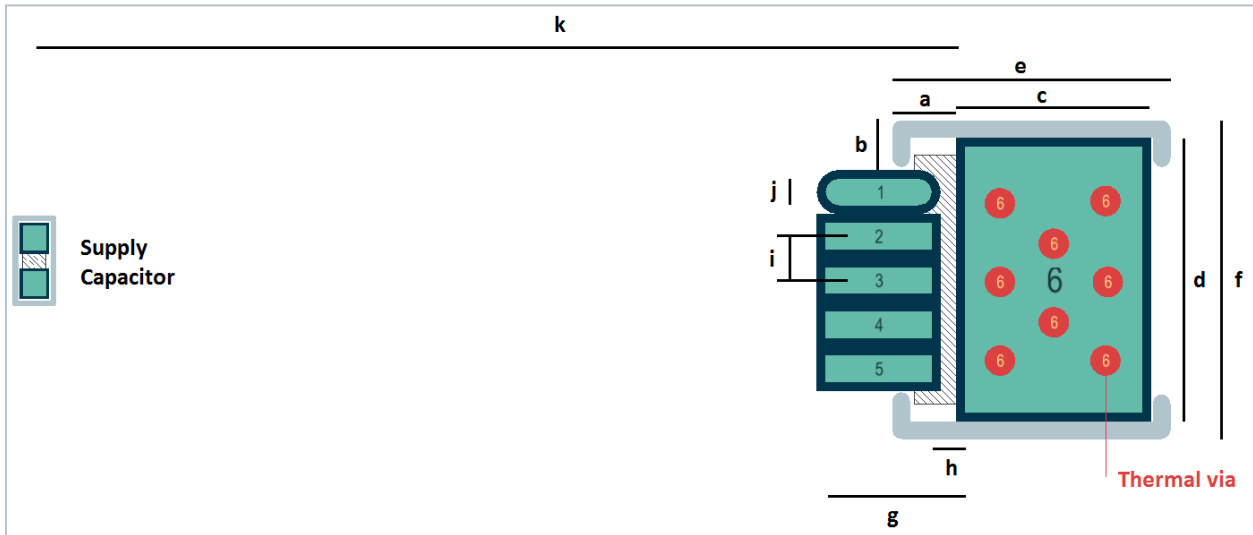

Figure 14: PCB footprint for MLX90632

Symbol	Distance [mm]
a	0.60
b	0.25
c	2.10
d	2.50
e	3.00
f	3.00
g	0.60/0.80/1.00
h	0.40
i	0.50
j	0.30
k	10 (max.)

Table 12 : PCB footprint dimensions for MLX90632

15. Application schematic

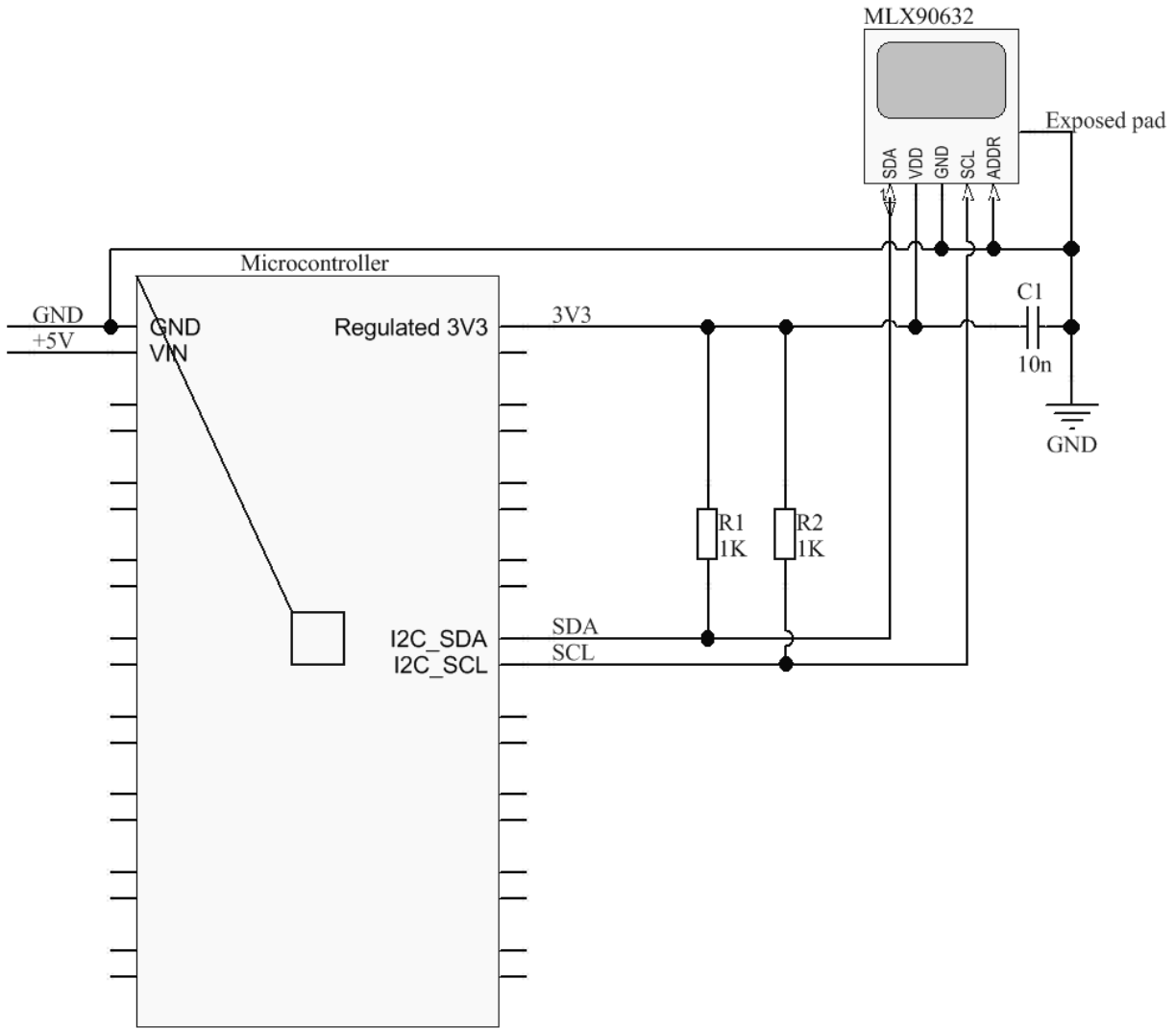

Figure 15: Typical application schematic for I²C communication with MLX90632

16. Standard information regarding manufacturability of Melexis products with different soldering processes

The MLX90632 is a MSL-3 device.

Our products are classified and qualified regarding soldering technology, solderability and moisture sensitivity level according to following test methods:

Reflow Soldering SMD's (Surface Mount Device)s

- IPC/JEDEC J-STD-020
Moisture/Reflow Sensitivity Classification for Nonhermetic Solid State Surface Mount Devices (Classification reflow profiles according to table 5-2)
- EIA/JEDEC JESD22-A113
Preconditioning of Nonhermetic Surface Mount Devices Prior to Reliability Testing (Reflow profiles according to table 2)

Wave Soldering SMD's (Surface Mount Device)s and THD's (Through Hole Device)s

- EN60749-20
Resistance of plastic- encapsulated SMD's to combined effect of moisture and soldering heat
- EIA/JEDEC JESD22-B106 and EN60749-15
Resistance to soldering temperature for through-hole mounted devices

Iron Soldering THD's (Through Hole Device)s

- EN60749-15
Resistance to soldering temperature for through-hole mounted devices

Solderability SMD's (Surface Mount Device)s and THD's (Through Hole Device)s

- EIA/JEDEC JESD22-B102 and EN60749-21
Solderability

For all soldering technologies deviating from above mentioned standard conditions (regarding peak temperature, temperature gradient, temperature profile etc.) additional classification and qualification tests have to be agreed upon with Melexis.

The application of Wave Soldering for SMD's is allowed only after consulting Melexis regarding assurance of adhesive strength between device and board.

Melexis recommends reviewing on our web site the General Guidelines [soldering recommendation](http://www.melexis.com/Quality_soldering.aspx) (http://www.melexis.com/Quality_soldering.aspx).

Melexis is contributing to global environmental conservation by promoting **lead free** solutions. For more information on qualifications of **RoHS** compliant products (RoHS = European directive on the Restriction Of the use of certain Hazardous Substances) please visit the quality page on our website: <http://www.melexis.com/quality.aspx>

17. ESD Precautions

Electronic semiconductor products are sensitive to Electro Static Discharge (ESD). Always observe Electro Static Discharge control procedures whenever handling semiconductor products.

18. FAQ

1. Significant contamination at the optical input side (sensor filter) might cause unknown additional filtering/distortion of the optical signal and therefore result in unspecified errors.
2. IR sensors are inherently susceptible to errors caused by thermal gradients. There are physical reasons for these phenomena and, in spite of the careful design of the MLX90632, it is recommended not to subject the MLX90632 to strong heat transfer and especially transient conditions.
3. The MLX90632 are designed and calibrated to operate as a non-contact thermometer in settled conditions.
4. Upon power-up the MLX90632 passes embedded checking and calibration routines. During these routines the output is not defined and it is recommended to wait for the specified POR time before reading the module. Very slow power-up may cause the embedded POR circuitry to trigger on inappropriate levels, resulting in unspecified operation and this is not recommended.
5. Capacitive loading on an I²C bus can degrade the communication. Some improvement is possible with use of current sources compared to resistors in pull-up circuitry. Further improvement is possible with specialized commercially available bus accelerators.
6. A sleep mode is available in the MLX90632. This mode is entered and exited via the I²C compatible 2-wire communication.
7. A power supply decoupling capacitor is needed as with most integrated circuits. The MLX90632 is a mixed-signal device with integrated sensors, small signal analog part, digital part and I/O circuitry. In order to keep the noise low, power supply switching noise needs to be decoupled. High noise from external circuitry can also affect noise performance of the device. In many applications a 10nF SMD ceramic capacitor close to the Vdd and Vss pins would be a good choice. It should be noted that not only the trace to the Vdd pin needs to be short, but also the one to the Vss pin.

19. Table of figures

Figure 1: Image of MLX90632.....	1
Figure 2: MLX90632 pinout, TOP view	8
Figure 3: Block diagram	10
Figure 4: Addressed read	16
Figure 5: Addressed write	16
Figure 6: Global reset	17
Figure 7: Addressed reset	17
Figure 8: EEPROM unlock.....	17
Figure 9: Direct read.....	18
Figure 10 : Accuracy table for VDD = 3.3V	27
Figure 11: Field of View measurement principle	28
Figure 12: Field of View of MLX90632	28
Figure 13: Package dimensions for MLX90632 (FoV = 50°)	29
Figure 14: PCB footprint for MLX90632	30
Figure 15: Typical application schematic for I ² C communication with MLX90632.....	31

20. Disclaimer

Devices sold by Melexis are covered by the warranty and patent indemnification provisions appearing in its Term of Sale. Melexis makes no warranty, express, statutory, implied, or by description regarding the information set forth herein or regarding the freedom of the described devices from patent infringement. Melexis reserves the right to change specifications and prices at any time and without notice. Therefore, prior to designing this product into a system, it is necessary to check with Melexis for current information. This product is intended for use in normal commercial applications. Applications requiring extended temperature range, unusual environmental requirements, or high reliability applications, such as military, medical life-support or life-sustaining equipment are specifically not recommended without additional processing by Melexis for each application.

The information furnished by Melexis is believed to be correct and accurate. However, this User Manual is intended as an aid to enable a user to install engineering parts of the MLX90632 into his own application for evaluation. While Melexis intends for the final production part of the MLX90632 to be comparable to the engineering parts, it is highly probable that changes will still be implemented.

Melexis shall not be liable to recipient or any third party for any damages, including but not limited to personal injury, property damage, loss of profits, loss of use, interrupt of business or indirect, special incidental or consequential damages, of any kind, in connection with or arising out of the furnishing, performance or use of the technical data herein. No obligation or liability to recipient or any third party shall arise or flow out of Melexis' rendering of technical or other services.

© 2017 Melexis N.V. All rights reserved.

21. Contact Information

For the latest version of this document, go to our website at
www.melexis.com

Or for additional information contact Melexis Direct:

Europe, Africa, Asia:

Phone: +32 1367 0495

E-mail: sales_europe@melexis.com

America:

Phone: +1 248 306 5400

E-mail: sales_usa@melexis.com

ISO/TS 16949 and ISO14001 Certified