

# TEST REPORT

Report No.: BCTC2407009323B

---

Applicant: LiPol Battery Co., Ltd

---

Product Name: Rechargeable Lithium Polymer Battery

---

Product Type: LP783450

---

Tested Date: 2024-07-20~2024-08-03

---

Issued Date: 2024-08-06

---

**Shenzhen BCTC Testing Co., Ltd.**



**IEC 62133-2**

**Secondary cells and batteries containing alkaline or other non-acid electrolytes  
– Safety requirements for portable sealed secondary cells, and for batteries  
made from them, for use in portable applications – Part 2: Lithium systems**

**Report Number** .....: BCTC2407009323B

**Date of issue** .....: 2024-08-06

**Total number of pages**.....: 31 Pages

**Applicant’s name**.....: LiPol Battery Co., Ltd

**Address** .....: Block A-720, Longguangjiuzuan, Daling Community, Minzhi Street, Longhua District, Shenzhen, China

**Test specification:**

**Standard** .....: IEC 62133-2:2017, IEC 62133-2:2017/AMD1:2021

**Test procedure** .....: Commission Test

**Non-standard test method** .....: N/A

**Test Report Form No.**.....: IEC62133\_2C

**Test Report Form(s) Originator** ....: DEKRA Certification B.V.

**Master TRF**.....: Dated 2022-07-01

**Copyright © 2022 IEC System of Conformity Assessment Schemes for Electrotechnical Equipment and Components (IECEE System). All rights reserved.**

This publication may be reproduced in whole or in part for non-commercial purposes as long as the IECEE is acknowledged as copyright owner and source of the material. IECEE takes no responsibility for and will not assume liability for damages resulting from the reader's interpretation of the reproduced material due to its placement and context.

If this Test Report Form is used by non-IECEE members, the IECEE/IEC logo and the reference to the CB Scheme procedure shall be removed.

**This report is not valid as a CB Test Report unless signed by an approved CB Testing Laboratory and appended to a CB Test Certificate issued by an NCB in accordance with IECEE 02.**

**General disclaimer:**

The test results presented in this report relate only to the object tested.

This report shall not be reproduced except in full, without the written approval of Shenzhen BCTC Testing Co., Ltd. This report may be altered or revised by Shenzhen BCTC Testing Co., Ltd. personnel only, and shall be noted in the revision section of the report. The test results in the report only apply to the tested samples.

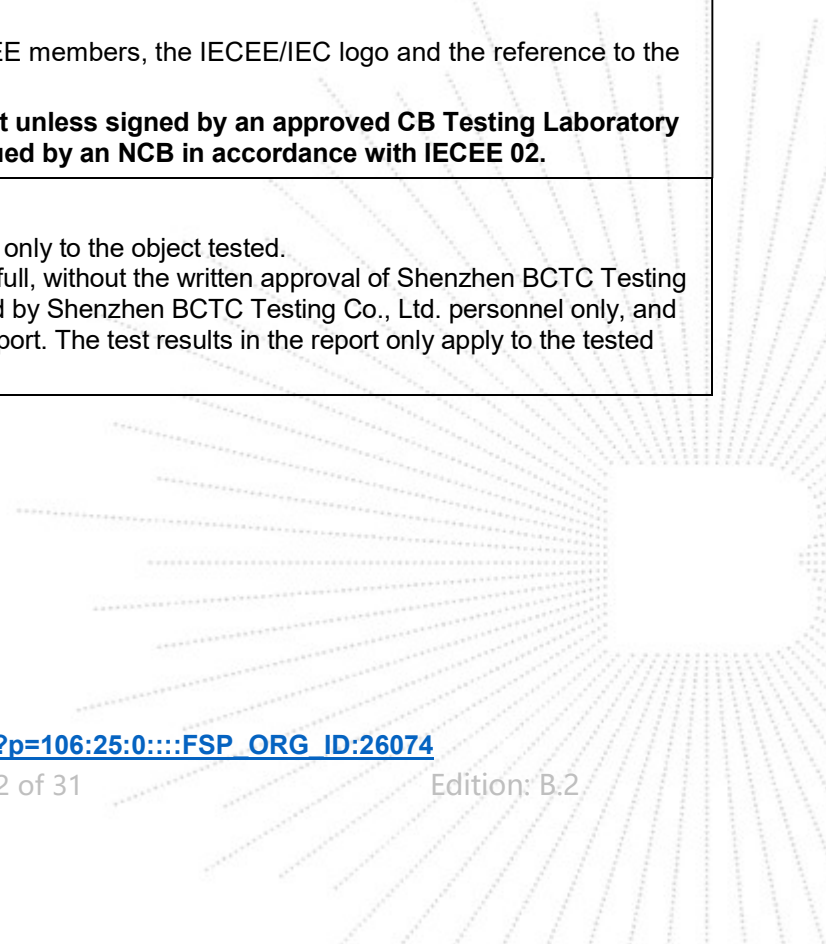

<b>Test item description</b> ..... :	Rechargeable Lithium Polymer Battery
<b>Trade Mark</b> ..... :	N/A
<b>Manufacturer</b> .....	LiPol Battery Co., Ltd Block A-720, Longguangjiuzuan, Daling Community, Minzhi Street, Longhua District, Shenzhen, China
<b>Model/Type reference</b> ..... :	LP783450
<b>Ratings</b> ..... :	3.7V, 1500mAh, 5.55Wh

**Responsible Testing Laboratory (as applicable), testing procedure and testing location(s):**

<b>Testing Laboratory:</b>	Shenzhen BCTC Testing Co., Ltd.	
<b>Testing location/ address</b> ..... :	1-2/F., Building B, Pengzhou Industrial Park, No.158, Fuyuan 1st Road, Zhancheng, Fuhai Subdistrict, Bao'an District, Shenzhen, Guangdong, China	
<b>Tested by (name, function, signature)</b> ..... :	George Hou (Project handler)	<i>George Hou</i>
<b>Approved by (name, function, signature)</b> ... :	Andre Yu (Reviewer)	<i>Andre Yu</i>

**List of Attachments (including a total number of pages in each attachment):**

National Differences (0 page)  
Enclosures (7 pages)

**Summary of testing:**

<b>Tests performed (name of test and test clause):</b> 7.2.1 Continuous charging at constant voltage (cells); 7.3.1 External short circuit (cell); 7.3.2 External short circuit (battery); 7.3.3 Free fall (cell and battery); 7.3.4 Thermal abuse (cells); 7.3.5 Crush (cells); 7.3.6 Over-charging of battery; 7.3.7 Forced discharge (cells); 7.3.8 Mechanical test (batteries); 7.3.9 Design evaluation – Forced internal short-circuit (cells)	<b>Testing location:</b> Shenzhen BCTC Testing Co., Ltd. 1-2/F., Building B, Pengzhou Industrial Park, No.158, Fuyuan 1st Road, Zhancheng, Fuhai Subdistrict, Bao'an District, Shenzhen, Guangdong, China
---	---

**Summary of compliance with National Differences (List of countries addressed):**

N/A

The product fulfils the requirements of **EN 62133-2: 2017, EN 62133-2: 2017/A1:2021.**

TC  
3C  
PPR  
Report

**Copy of marking plate:**

**The artwork below may be only a draft. The use of certification marks on a product must be authorized by the respective NCBs that own these marks.**

Rechargeable Lithium Polymer Battery  
LP783450  
3.7V, 1500mAh, 5.55Wh  
1ICP9/35/52 YYYMMDD  
LiPol Battery Co., Ltd  
Caution: Not short circuit

**Remark:**

“YYYY” represents the year of manufacture;

“MM” represents the month of manufacture;

“DD” represents the date of manufacture.

<b>Test item particulars</b> ..... :	
<b>Classification of installation and use</b> ..... :	To be defined in final product
<b>Supply Connection</b> ..... :	DC connection
<b>Recommend charging method declared by the manufacturer</b> .....	Charge at constant current 300mA until the voltage reaches 4.2V, then charge at 4.2V until charge current declines to 15mA.
<b>Discharge current (0,2 It A)</b> .....	300mA
<b>Specified final voltage</b> ..... :	2.75V
<b>Upper limit charging voltage per cell</b> ..... :	4.25V
<b>Maximum charging current</b> .....	750mA
<b>Charging temperature upper limit</b> .....	45°C
<b>Charging temperature lower limit</b> ..... :	10°C
<b>Polymer cell electrolyte type</b> ..... :	<input type="checkbox"/> gel polymer <input type="checkbox"/> solid polymer <input checked="" type="checkbox"/> N/A
<b>Possible test case verdicts:</b>	
- test case does not apply to the test object..... :	N/A
- test object does meet the requirement..... :	P (Pass)
- test object does not meet the requirement..... :	F (Fail)
<b>Testing</b> ..... :	
<b>Date of receipt of test item</b> .....	2024-07-20
<b>Date (s) of performance of tests</b> .....	2024-07-20 to 2024-08-03
<b>General remarks:</b>	
"(See Enclosure #)" refers to additional information appended to the report. "(See appended table)" refers to a table appended to the report.	
Throughout this report a <input type="checkbox"/> comma / <input checked="" type="checkbox"/> point is used as the decimal separator.	
<b>Name and address of factory (ies)</b> .....	LiPol Battery Co., Ltd Block A-720, Longguangjiuzuan, Daling Community, Minzhi Street, Longhua District, Shenzhen, China.

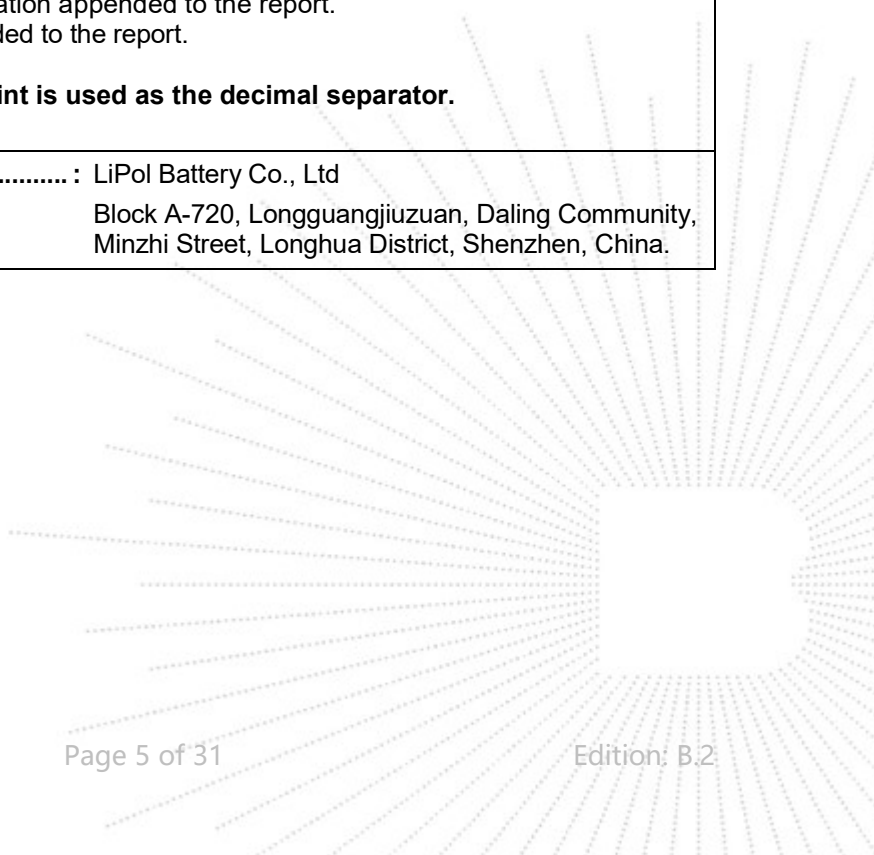

**General product information and other remarks:**

Only test are performed in this report. The technology documentations, which should be provided by the manufacturer for the review requirement of IEC 62133, are not included in this report.

This battery is constructed with one lithium-ion cell, and has overcharge, over-discharge, over current and short-circuits proof circuit.

The cell consists of the positive electrode plate, negative electrode plate, separator, electrolyte and aluminum film.

Additionally, detailed information of the battery and cell, as following:

Product	Cell	Battery
Model	LP783450	LP783450
Rated capacity	1500mAh	1500mAh
Nominal voltage	3.7V	3.7V
Standard charge current	300mA	300mA
Standard discharge current	750mA	750mA
Maximum charge current	750mA	750mA
Maximum discharge current	1500mA	1500mA
Normal charging voltage	4.2V	4.2V
Charge cut-off current	15mA	15mA
Final discharge voltage	2.75V	2.75V
Upper limit charging voltage	4.25V	4.25V
Charging temperature range	10-45°C	10-45°C

 CO. LTD

IEC 62133-2			
Clause	Requirement + Test	Result - Remark	Verdict
<b>4</b>	<b>PARAMETER MEASUREMENT TOLERANCES</b>		P
	Parameter measurement tolerances		P
<b>5</b>	<b>GENERAL SAFETY CONSIDERATIONS</b>		P
<b>5.1</b>	<b>General</b>		P
	Cells and batteries so designed and constructed that they are safe under conditions of both intended use and reasonably foreseeable misuse		P
<b>5.2</b>	<b>Insulation and wiring</b>		P
	The insulation resistance between the positive terminal and externally exposed metal surfaces of the battery (excluding electrical contact surfaces) is not less than 5 MΩ	No externally exposed metal surfaces.	N/A
	Insulation resistance (MΩ) ..... :		—
	Internal wiring and insulation are sufficient to withstand maximum anticipated current, voltage and temperature requirements		P
	Orientation of wiring maintains adequate clearances and creepage distances between conductors		P
	Mechanical integrity of internal connections accommodates reasonably foreseeable misuse		P
<b>5.3</b>	<b>Venting</b>		P
	Battery cases and cells incorporate a pressure relief mechanism or are constructed so that they relieve excessive internal pressure at a value and rate that will preclude rupture, explosion and self-ignition		P
	Encapsulation used to support cells within an outer casing does not cause the battery to overheat during normal operation nor inhibit pressure relief		P
<b>5.4</b>	<b>Temperature, voltage and current management</b>		P
	Batteries are designed such that abnormal temperature rise conditions are prevented		P
	Batteries are designed to be within temperature, voltage and current limits specified by the cell manufacturer		P
	Batteries are provided with specifications and charging instructions for equipment manufacturers so that specified chargers are designed to maintain charging within the temperature, voltage and current limits specified		P
<b>5.5</b>	<b>Terminal contacts</b>		P

IEC 62133-2			
Clause	Requirement + Test	Result - Remark	Verdict
	The size and shape of the terminal contacts ensure that they can carry the maximum anticipated current		P
	External terminal contact surfaces are formed from conductive materials with good mechanical strength and corrosion resistance		P
	Terminal contacts are arranged to minimize the risk of short circuits		P
<b>5.6</b>	<b>Assembly of cells into batteries</b>		P
5.6.1	General		P
	Each battery has an independent control and protection for current, voltage, temperature and any other parameter required for safety and to maintain the cells within their operating region		P
	This protection may be provided external to the battery such as within the charger or the end devices		N/A
	If protection is external to the battery, the manufacturer of the battery provide this safety relevant information to the external device manufacturer for implementation		N/A
	If there is more than one battery housed in a single battery case, each battery has protective circuitry that can maintain the cells within their operating regions		N/A
	Manufacturers of cells specify current, voltage and temperature limits so that the battery manufacturer/designer may ensure proper design and assembly		P
	Batteries that are designed for the selective discharge of a portion of their series connected cells incorporate circuitry to prevent operation of cells outside the limits specified by the cell manufacturer		N/A
	Protective circuit components are added as appropriate and consideration given to the end-device application		N/A
	The manufacturer of the battery provide a safety analysis of the battery safety circuitry with a test report including a fault analysis of the protection circuit under both charging and discharging conditions confirming the compliance		N/A
5.6.2	Design recommendation		P
	For the battery consisting of a single cell or a single cellblock, it is recommended that the charging voltage of the cell does not exceed the upper limit of the charging voltage specified in Table 2		P





IEC 62133-2			
Clause	Requirement + Test	Result - Remark	Verdict
	For the battery consisting of series-connected plural single cells or series-connected plural cellblocks, it is recommended that the voltages of any one of the single cells or single cellblocks does not exceed the upper limit of the charging voltage, specified in Table 2, by monitoring the voltage of every single cell or the single cellblocks		N/A
	For the battery consisting of series-connected plural single cells or series-connected plural cellblocks, it is recommended that charging is stopped when the upper limit of the charging voltage is exceeded for any one of the single cells or single cellblocks by measuring the voltage of every single cell or the single cellblocks		N/A
	For batteries consisting of series-connected cells or cell blocks, nominal charge voltage are not counted as an overcharge protection		N/A
	For batteries consisting of series-connected cells or cell blocks, cells have closely matched capacities, be of the same design, be of the same chemistry and be from the same manufacturer		N/A
	It is recommended that the cells and cell blocks are not discharged beyond the cell manufacturer's specified final voltage		P
	For batteries consisting of series-connected cells or cell blocks, cell balancing circuitry are incorporated into the battery management system		N/A
5.6.3	Mechanical protection for cells and components of batteries		P
	Mechanical protection for cells, cell connections and control circuits within the battery are provided to prevent damage as a result of intended use and reasonably foreseeable misuse		P
	The mechanical protection can be provided by the battery case or it can be provided by the end product enclosure for those batteries intended for building into an end product		N/A
	The battery case and compartments housing cells are designed to accommodate cell dimensional tolerances during charging and discharging as recommended by the cell manufacturer		N/A
	For batteries intended for building into a portable end product, testing with the battery installed within the end product is considered when conducting mechanical tests		N/A
<b>5.7</b>	<b>Quality plan</b>		<b>P</b>

IEC 62133-2			
Clause	Requirement + Test	Result - Remark	Verdict
	The manufacturer prepares and implements a quality plan that defines procedures for the inspection of materials, components, cells and batteries and which covers the whole process of producing each type of cell or battery	ISO 9001 certificate provided.	P
<b>5.8</b>	<b>Battery safety components</b>		N/A

<b>6</b>	<b>TYPE TEST AND SAMPLE SIZE</b>		P
	Tests are made with the number of cells or batteries specified in Table 1 using cells or batteries that are not more than six months old	Tests are performed according to specified in Table 1 of this standard. The samples are not more than six months old.	P
	The internal resistance of coin cells are measured in accordance with Annex D. Coin cells with internal resistance less than or equal to 3 $\Omega$ are tested in accordance with Table 1	Not coin cell.	N/A
	Unless otherwise specified, tests are carried out in an ambient temperature of 20 °C $\pm$ 5 °C		P
	The safety analysis of 5.6.1 identify those components of the protection circuit that are critical for short-circuit, overcharge and over discharge protection		N/A
	When conducting the short-circuit test, consideration is given to the simulation of any single fault condition that is likely to occur in the protecting circuit that would affect the short-circuit test		P

<b>7</b>	<b>SPECIFIC REQUIREMENTS AND TESTS</b>		P
<b>7.1</b>	<b>Charging procedure for test purposes</b>		P
7.1.1	First procedure		P
	This charging procedure applies to subclauses other than those specified in 7.1.2		P
	Unless otherwise stated in this document, the charging procedure for test purposes is carried out in an ambient temperature of 20 °C $\pm$ 5 °C, using the method declared by the manufacturer		P
	Prior to charging, the battery has been discharged at 20 °C $\pm$ 5 °C at a constant current of 0,2 It A down to a specified final voltage		P
7.1.2	Second procedure		P
	This charging procedure applies only to 7.3.1, 7.3.4, 7.3.5, and 7.3.9		P

IEC 62133-2			
Clause	Requirement + Test	Result - Remark	Verdict
	After stabilization for 1 h to 4 h, at an ambient temperature of the highest test temperature and the lowest test temperature, respectively, as specified in Table 2, cells are charged by using the upper limit charging voltage and maximum charging current, until the charging current is reduced to 0,05 It A, using a constant current to constant voltage charging method	Charge temperature 10-45°C declared. 45°C and 10°C were used as highest test temperature and lowest test temperature during tests.	P
<b>7.2</b>	<b>Intended use</b>		P
7.2.1	Continuous charging at constant voltage (cells)		P
	Fully charged cells are subjected for 7 days to a charge using the charging method for current and standard voltage specified by the cell manufacturer		P
	Results: no fire, no explosion, no leakage..... :	(See appended table 7.2.1)	P
7.2.2	Case stress at high ambient temperature (battery)		N/A
	Oven temperature (°C)..... :		—
	Results: no physical distortion of the battery case resulting in exposure of internal protective components and cells		N/A
<b>7.3</b>	<b>Reasonably foreseeable misuse</b>		P
7.3.1	External short-circuit (cell)		P
	The cells were tested until one of the following occurred:		P
	- 24 hours elapsed; or		N/A
	- The case temperature declined by 20 % of the maximum temperature rise		P
	Results: no fire, no explosion..... :	(See appended table 7.3.1)	P
7.3.2	External short-circuit (battery)		P
	The batteries were tested until one of the following occurred:		P
	- 24 hours elapsed; or		N/A
	- The case temperature declined by 20 % of the maximum temperature rise		P
	In case of rapid decline in short circuit current, the battery pack remained on test for an additional one hour after the current reached a low end steady state condition		P
	A single fault in the discharge protection circuit is conducted on one to four (depending upon the protection circuit) of the five samples before conducting the short-circuit test		P



IEC 62133-2			
Clause	Requirement + Test	Result - Remark	Verdict
	A single fault applies to protective component parts such as MOSFET (metal oxide semiconductor field-effect transistor), fuse, thermostat or positive temperature coefficient (PTC) thermistor	Single fault on U2.	P
	Results: no fire, no explosion .....	(See appended table 7.3.2)	P
7.3.3	Free fall		P
	Results: no fire, no explosion		P
7.3.4	Thermal abuse (cells)		P
	Oven temperature (°C) .....	130	—
	Results: no fire, no explosion		P
7.3.5	Crush (cells)		P
	The crushing force was released upon:		P
	- The maximum force of 13 kN ± 0,78 kN has been applied; or		P
	- An abrupt voltage drop of one-third of the original voltage has been obtained		N/A
	Results: no fire, no explosion .....	(See appended table 7.3.5)	P
7.3.6	Over-charging of battery		P
	The supply voltage which is:		P
	- 1,4 times the upper limit charging voltage presented in Table A.1 (but not to exceed 6,0 V) for single cell/cell block batteries or	5.95V used for test.	P
	- 1,2 times the upper limit charging voltage resented in Table A.1 per cell for series connected multi-cell batteries, and		N/A
	- Sufficient to maintain a current of 2,0 It A throughout the duration of the test or until the supply voltage is reached		P
	Test was continued until the temperature of the outer casing:		P
	- Reached steady state conditions (less than 10 °C change in 30-minute period); or		N/A
	- Returned to ambient		P
	Results: no fire, no explosion .....	(See appended table 7.3.6)	P
7.3.7	Forced discharge (cells)		P
	Discharge a single cell to the lower limit discharge voltage specified by the cell manufacturer		P
	The discharged cell is then subjected to a forced discharge at 1 It A to the negative value of the upper limit charging voltage		P

IEC 62133-2			
Clause	Requirement + Test	Result - Remark	Verdict
	- The discharge voltage reaches the negative value of upper limit charging voltage within the testing duration. The voltage is maintained at the negative value of the upper limit charging voltage by reducing the current for the remainder of the testing duration		N/A
	- The discharge voltage does not reach the negative value of upper limit charging voltage within the testing duration. The test is terminated at the end of the testing duration		P
	Results: no fire, no explosion .....	(See appended table 7.3.7)	P
7.3.8	Mechanical tests (batteries)		P
7.3.8.1	Vibration		P
	Results: no fire, no explosion, no rupture, no leakage or venting. ....	(See appended table 7.3.8.1)	P
7.3.8.2	Mechanical shock		P
	Results: no leakage, no venting, no rupture, no explosion and no fire .....	(See appended table 7.3.8.2)	P
7.3.9	Design evaluation – Forced internal short-circuit (cells)		P
	The cells complied with national requirement for .....	France, Japan, Korea, Switzerland	—
	The pressing was stopped upon:		P
	- A voltage drop of 50 mV has been detected; or		N/A
	- The pressing force of 800 N (cylindrical cells) or 400 N (prismatic cells) has been reached	400 N for prismatic cells.	P
	Results: no fire .....	(See appended table 7.3.9)	P
<b>8</b>	<b>INFORMATION FOR SAFETY</b>		P
<b>8.1</b>	<b>General</b>		P
	Manufacturers of secondary cells provides information about current, voltage and temperature limits of their products		P
	Manufacturers of batteries provides information regarding how to minimize and mitigate hazards to equipment manufacturers or end-users		P
	Systems analyses are performed by device manufacturers to ensure that a particular battery design prevents hazards from occurring during use of a product		N/A
	As appropriate, any information relating to hazard avoidance resulting from a system analysis is provided to the end user		P

IEC 62133-2			
Clause	Requirement + Test	Result - Remark	Verdict
	Do not allow children to replace batteries without adult supervision		P
<b>8.2</b>	<b>Small cell and battery safety information</b>	Not small battery	N/A
	The following warning language is to be provided with the information packaged with the small cells and batteries or equipment using them:		N/A
	- Keep small cells and batteries which are considered swallowable out of the reach of children		N/A
	- Swallowing may lead to burns, perforation of soft tissue, and death. Severe burns can occur within 2 h of ingestion		N/A
	- In case of ingestion of a cell or battery, seek medical assistance promptly		N/A
<b>9</b>	<b>MARKING</b>		P
<b>9.1</b>	<b>Cell marking</b>		P
	Cells are marked as specified in IEC 61960, except coin cells		N/A
	Coin cells whose external surface area is too small to accommodate the markings on the cells show the designation and polarity		N/A
	By agreement between the cell manufacturer and the battery and/or end product manufacturer, component cells used in the manufacture of a battery need not be marked		P
<b>9.2</b>	<b>Battery marking</b>		P
	Batteries are marked as specified in IEC 61960, except for coin batteries		P
	Coin batteries whose external surface area is too small to accommodate the markings on the batteries show the designation and polarity		N/A
	Batteries are marked with an appropriate caution statement		P
	- Terminals have clear polarity marking on the external surface of the battery, or		N/A
	- Not be marked with polarity markings if the design of the external connector prevents reverse polarity connections		P
<b>9.3</b>	<b>Caution for ingestion of small cells and batteries</b>		N/A
	Coin cells and batteries identified as small batteries include a caution statement regarding the hazards of ingestion in accordance with 8.2	Not coin batteries	N/A



IEC 62133-2			
Clause	Requirement + Test	Result - Remark	Verdict
	Small cells and batteries are intended for direct sale in consumer-replaceable applications, caution for ingestion is given on the immediate package	Not intended for direct sale	N/A
<b>9.4</b>	<b>Other information</b>		P
	The following information are marked on or supplied with the battery:		P
	- Storage and disposal instructions		P
	- Recommended charging instructions		P

<b>10</b>	<b>PACKAGING AND TRANSPORT</b>		P
	Packaging for coin cells are not be small enough to fit within the limits of the ingestion gauge of Figure 3	Not coin cell.	N/A

<b>ANNEX A</b>	<b>CHARGING AND DISCHARGING RANGE OF SECONDARY LITHIUM ION CELLS FOR SAFE USE</b>		P
<b>A.1</b>	<b>General</b>		P
<b>A.2</b>	<b>Safety of lithium ion secondary battery</b>		P
<b>A.3</b>	<b>Consideration on charging voltage</b>		P
A.3.1	General		P
A.3.2	Upper limit charging voltage		P
A.3.2.1	General		P
A.3.2.2	Explanation of safety viewpoint		N/A
A.3.2.3	Safety requirements, when different upper limit charging voltage is applied		N/A
<b>A.4</b>	<b>Consideration of temperature and charging current</b>		P
A.4.1	General		P
A.4.2	Recommended temperature range	Charging temperature range declared by client is 10-45°C	P
A.4.2.1	General		P
A.4.2.2	Safety consideration when a different recommended temperature range is applied		P
A.4.3	High temperature range	45°C used for test.	N/A
A.4.3.1	General		N/A
A.4.3.2	Explanation of safety viewpoint		N/A
A.4.3.3	Safety considerations when specifying charging conditions in the high temperature range		N/A

IEC 62133-2			
Clause	Requirement + Test	Result - Remark	Verdict
A.4.3.4	Safety considerations when specifying a new upper limit in the high temperature range		N/A
A.4.4	Low temperature range	10°C used for test.	N/A
A.4.4.1	General		N/A
A.4.4.2	Explanation of safety viewpoint		N/A
A.4.4.3	Safety considerations, when specifying charging conditions in the low temperature range		N/A
A.4.4.4	Safety considerations when specifying a new lower limit in the low temperature range		N/A
A.4.5	Scope of the application of charging current		P
A.4.6	Consideration of discharge		P
A.4.6.1	General		P
A.4.6.2	Final discharge voltage and explanation of safety viewpoint		P
A.4.6.3	Discharge current and temperature range		P
A.4.6.4	Scope of application of the discharging current		P
<b>A.5</b>	<b>Sample preparation</b>		P
A.5.1	General		P
A.5.2	Insertion procedure for nickel particle to generate internal short		P
A.5.3	Disassembly of charged cell		P
A.5.4	Shape of nickel particle		P
A.5.5	Insertion of nickel particle in cylindrical cell		N/A
A.5.5.1	Insertion of nickel particle in winding core		N/A
A.5.5.2	Marking the position of the nickel particle on both ends of the winding core of the separator		N/A
A.5.6	Insertion of nickel particle in prismatic cell		P
<b>A.6</b>	<b>Experimental procedure of the forced internal short-circuit test</b>		P
A.6.1	Material and tools for preparation of nickel particle		P
A.6.2	Example of a nickel particle preparation procedure		P
A.6.3	Positioning (or placement) of a nickel particle		P
A.6.4	Damaged separator precaution		P
A.6.5	Caution for rewinding separator and electrode		P
A.6.6	Insulation film for preventing short-circuit		P
A.6.7	Caution when disassembling a cell		P
A.6.8	Protective equipment for safety		P



IEC 62133-2			
Clause	Requirement + Test	Result - Remark	Verdict
A.6.9	Caution in the case of fire during disassembling		P
A.6.10	Caution for the disassembling process and pressing the electrode core		P
A.6.11	Recommended specifications for the pressing device		P
<b>ANNEX B</b>	<b>RECOMMENDATIONS TO EQUIPMENT MANUFACTURERS AND BATTERY ASSEMBLERS</b>		<b>P</b>
<b>ANNEX C</b>	<b>RECOMMENDATIONS TO THE END-USERS</b>		<b>N/A</b>
<b>ANNEX D</b>	<b>MEASUREMENT OF THE INTERNAL AC RESISTANCE FOR COIN CELLS</b>		<b>N/A</b>
<b>D.1</b>	<b>General</b>		<b>N/A</b>
<b>D.2</b>	<b>Method</b>		<b>N/A</b>
	A sample size of three coin cells is required for this measurement		<b>N/A</b>
	Coin cells with an internal resistance greater than 3 $\Omega$ require no further testing .....	(See appended table D.2)	<b>N/A</b>
	Coin cells with an internal resistance less than or equal to 3 $\Omega$ are subjected to the testing according to Clause 6 and Table 1		<b>N/A</b>
<b>ANNEX E</b>	<b>PACKAGING AND TRANSPORT</b>		<b>P</b>
<b>ANNEX F</b>	<b>COMPONENT STANDARDS REFERENCES</b>		<b>N/A</b>



IEC 62133-2			
Clause	Requirement + Test	Result - Remark	Verdict

7.2.1	TABLE: Continuous charging at constant voltage (cells)				P
Sample no.	Recommended charging voltage V <sub>c</sub> (Vdc)	Recommended charging current I <sub>rec</sub> (A)	OCV before test (Vdc)	Results	
C01	4.2	0.3	4.198	A, B	
C02	4.2	0.3	4.198	A, B	
C03	4.2	0.3	4.198	A, B	
C04	4.2	0.3	4.197	A, B	
C05	4.2	0.3	4.198	A, B	

**Supplementary information:**  
 A - No fire or explosion;  
 B - No leakage;  
 C - Others (please explain).

7.3.1	TABLE: External short-circuit (cell)					P
Sample no.	Ambient T (°C)	OCV before test (Vdc)	Resistance of circuit (mΩ)	Maximum case temperature rise ΔT (K)	Results	
<b>Samples charged at charging temperature upper limit 45°C</b>						
C06	55.4	4.232	82	58.2	A, C	
C07	55.4	4.232	77	55.6	A, C	
C08	55.4	4.233	78	61.3	A, C	
C09	55.4	4.231	80	62.5	A, C	
C10	55.4	4.234	86	59.0	A, C	
<b>Samples charged at charging temperature lower limit 10°C</b>						
C11	55.6	4.174	84	64.2	A, C	
C12	55.6	4.176	82	67.3	A, C	
C13	55.6	4.174	78	58.8	A, C	
C14	55.6	4.174	76	57.0	A, C	
C15	55.6	4.175	79	62.4	A, C	

**Supplementary information:**  
 A - No fire or explosion;  
 B - The test was completed after 24 hours elapsed;  
 C - The test was completed after the cell casing cooled to 20% of the maximum temperature rise;  
 D - Others (please explain).

IEC 62133-2						
Clause	Requirement + Test				Result - Remark	Verdict
<b>7.3.2</b>	<b>TABLE: External short-circuit (battery)</b>					<b>P</b>
Sample no.	Ambient T (°C)	OCV before test (Vdc)	Resistance of circuit (mΩ)	Maximum case temperature rise ΔT (K)	Component single fault condition	Results
B01	22.4	4.185	82	98.6	SC U2	A, C
B02	22.4	4.186	88	104.2	SC U2	A, C
B03	22.4	4.186	78	102.0	SC U2	A, C
B04	22.4	4.187	72	99.4	SC U2	A, C
B05	22.4	4.186	84	100.5	--	A, D
<b>Supplementary information:</b>						
A - No fire or explosion;						
B - The test was completed after 24 hours elapsed;						
C - The test was completed after the case temperature declined by 20 % of the maximum temperature rise;						
D - Rapid decline in short circuit current, the battery pack remained on test for an additional one hour after the current reaches a low end steady state condition;						
E - Others (please explain).						
<b>SC-short circuit</b>						

<b>7.3.5</b>	<b>TABLE: Crush (cells)</b>				<b>P</b>
Sample no.	OCV before test (Vdc)	OCV at removal of crushing force (Vdc)	Maximum force applied to the cell during crush (kN)	Results	
<b>Samples charged at charging temperature upper limit 45°C</b>					
C29	4.232	4.231	12.95	A, B	
C30	4.232	4.232	12.95	A, B	
C31	4.230	4.230	12.96	A, B	
C32	4.233	4.233	12.96	A, B	
C33	4.231	4.231	12.95	A, B	
<b>Samples charged at charging temperature lower limit 10°C</b>					
C34	4.174	4.173	12.96	A, B	
C35	4.176	4.175	12.96	A, B	
C36	4.174	4.174	12.95	A, B	
C37	4.175	4.175	12.96	A, B	
C38	4.175	4.174	12.96	A, B	
<b>Supplementary information:</b>					
A - No fire or explosion;					
B - Force released after maximum level reached;					
C - An abrupt voltage drop of one-third of the original voltage has been obtained;					
D - Others (please explain).					

IEC 62133-2				
Clause	Requirement + Test	Result - Remark	Verdict	
<b>7.3.6</b>	<b>TABLE: Over-charging of battery</b>			<b>P</b>
Constant charging current (A).....:		<b>3</b>	—	
Supply voltage (Vdc).....:		<b>5.95</b>	—	
Sample no.	OCV before charging (Vdc)	Total charging time (minute)	Maximum outer case temperature (°C)	Results
B09	3.456	90	32.4	A, C
B10	3.438	90	31.8	A, C
B11	3.424	90	34.6	A, C
B12	3.466	90	32.2	A, C
B13	3.451	90	33.5	A, C
<b>Supplementary information:</b>				
A - No fire or explosion;				
B - The temperature of the outer casing reached steady state conditions (less than 10 °C change in 30-minute period);				
C - The temperature of the outer casing returned to ambient;				
D - Others (please explain).				

<b>7.3.7</b>	<b>TABLE: Forced discharge (cells)</b>				<b>P</b>
Sample no.	OCV before application of reverse charge (Vdc)	Measured reverse charge $I_t$ (A)	Lower limit discharge voltage (Vdc)	Results	
C39	3.426	1.5	2.75	A, C	
C40	3.457	1.5	2.75	A, C	
C41	3.442	1.5	2.75	A, C	
C42	3.450	1.5	2.75	A, C	
C43	3.431	1.5	2.	A, C	
<b>Supplementary information:</b>					
A - No fire or explosion;					
B - The voltage reach negative value of upper limit charging voltage;					
C - The voltage did not reach negative value of upper limit charging voltage;					
D - Others (please explain).					

<b>7.3.8.1</b>	<b>TABLE: Vibration</b>					<b>P</b>
Sample no.	OCV before test (Vdc)	OCV after test (Vdc)	Mass before test (g)	Mass after test (g)	Results	
B14	4.188	4.186	27.462	27.460	A	
B15	4.186	4.185	27.513	27.511	A	
B16	4.186	4.186	27.576	27.576	A	

IEC 62133-2			
Clause	Requirement + Test	Result - Remark	Verdict

**Supplementary information:**

A - No fire. No explosion. No leakage. No venting. No rupture;  
 B - Others (please explain).

7.3.8.2	TABLE: Mechanical shock					P
Sample no.	OCV before test (Vdc)	OCV after test (Vdc)	Mass before test (g)	Mass after test (g)	Results	
B17	4.185	4.184	27.464	27.464	A	
B18	4.186	4.186	27.812	27.812	A	
B19	4.185	4.185	27.573	27.571	A	

**Supplementary information:**

A - No fire. No explosion. No leakage. No venting. No rupture;  
 B - Others (please explain).

7.3.9	TABLE: Forced internal short circuit (cells)					P
Sample no.	Chamber ambient T (°C)	OCV before test (Vdc)	Particle location <sup>1)</sup>	Maximum applied pressure (N)	Results	
<b>Samples charged at charging temperature upper limit 45°C</b>						
C44	45	4.231	1	400.4	A	
C45	45	4.234	1	400.6	A	
C46	45	4.232	1	400.2	A	
C47	45	4.232	1	400.3	A	
C48	45	4.231	1	400.5	A	
<b>Samples charged at charging temperature lower limit 10°C</b>						
C49	10	4.176	1	400.7	A	
C50	10	4.174	1	400.3	A	
C51	10	4.172	1	400.1	A	
C52	10	4.171	1	400.2	A	
C53	10	4.175	1	400.4	A	

**Supplementary information:**

<sup>1)</sup> Identify one of the following:

- 1: Nickel particle inserted between positive and negative (active material) coated area.
- 2: Nickel particle inserted between positive aluminium foil and negative active material coated area.

A - No fire or explosion;  
 B - Others (please explain).

BCTC  
 3C  
 PPR  
 Report

IEC 62133-2				
Clause	Requirement + Test	Result - Remark		Verdict
<b>D.2</b>	<b>TABLE: Internal AC resistance for coin cells</b>			<b>N/A</b>
Sample no.	Ambient T (°C)	Store time (h)	Resistance Rac (Ω)	Results <sup>1)</sup>
<b>Supplementary information:</b> <sup>1)</sup> Coin cells with an internal resistance less than or equal to 3 Ω, see test result on corresponding tables according to Clause 6 and Table 1.				

TESTED  
 TO  
 OVER  
 t See

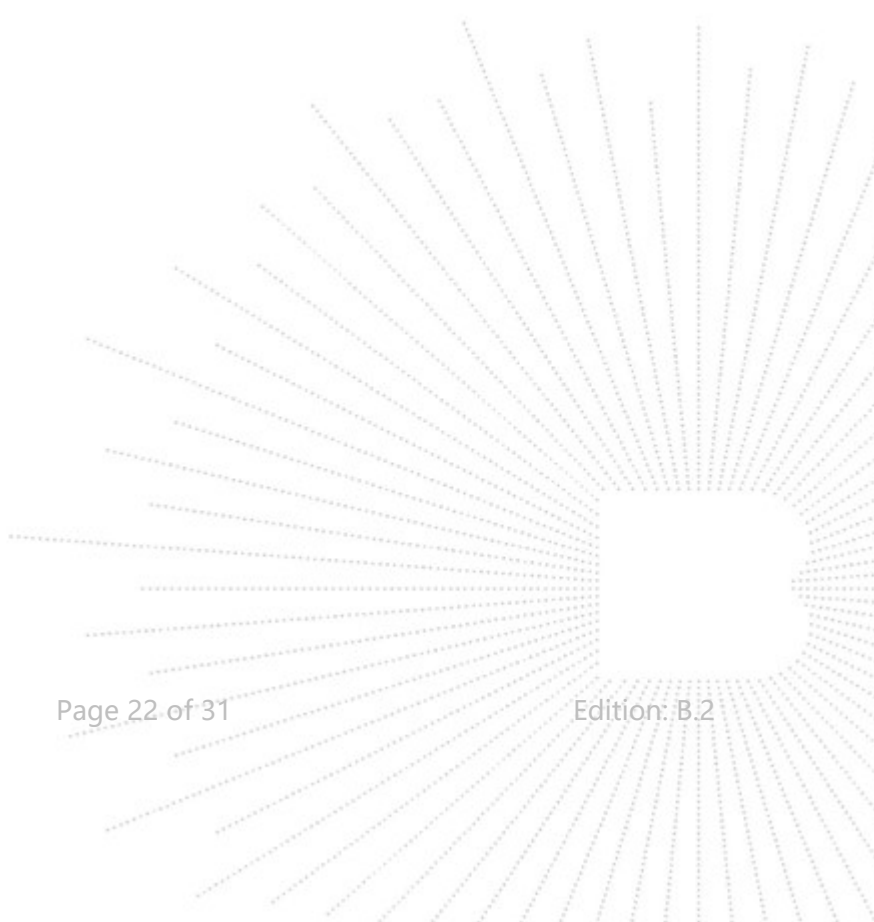

IEC 62133-2					
Clause	Requirement + Test	Result - Remark			Verdict
<b>TABLE: Critical components information</b>					<b>P</b>
Object / part No.	Manufacturer / trademark	Type / model	Technical data	Standard	Mark(s) of conformity <sup>1)</sup>
PCB	Shenzhen JiaLeXu Technology Co., LTD	2450	130°C	--	Tested with appliance
Wire	SHENZHEN YUNSHENGDA ELECTRONICS TECHNOLOGY CO LTD	1007	28AWG, 80°C, 300V	UL 758	E332481
Connector	Molex	78172-0200	2pins	--	Tested with appliance
Protective IC (U1)	ABLIC Inc.	G3M	V <sub>CU</sub> : 4.28V±0.05V, V <sub>DL</sub> : 2.8V±0.1V	--	Tested with appliance
MOSFET (U2)	GUANGDONG HOTTECH INDUSTRIAL CO., LTD.	8205A	V <sub>DS</sub> : 20V, V <sub>GS</sub> : ±8V, I <sub>D</sub> : 5A	--	Tested with appliance
Cell	LiPol Battery Co., Ltd	LP783450	3.7V, 1500mAh	IEC 62133-2:2017/AM D1:2021	Tested with appliance
-Electrolyte	Jiangsu Guotai International Group Co., Ltd.	9521	LiPF <sub>6</sub> , DMC, EMC, EC	--	--
-Separator	NKK Corporation	96548	Shutdown temperature: 130°C, PP+PE+PP	--	--
-Positive electrode	Dongguan MIC Technology Co., Ltd.	MIC001	LiCoO <sub>2</sub> , Conductive Additive, PVDF, Aluminum Foil	--	--
-Negative electrode	Sinmo technology Inc.	CRT-S	Carbon, Conductive Additive, Copper Foil	--	--
Supplementary information:					
1) Provided evidence ensures the agreed level of compliance. See OD-2039.					
2) The CBTL has verified the component information.					
License available upon request.					

## Enclosure

Supplement ID	Description
01	Over view photograph
02	Internal cell photograph
03	Cell photograph
04	PWB photograph
05	Dimension drawing
06	Circuit diagram and layout

CO., LTD



ID 01-Over view photograph

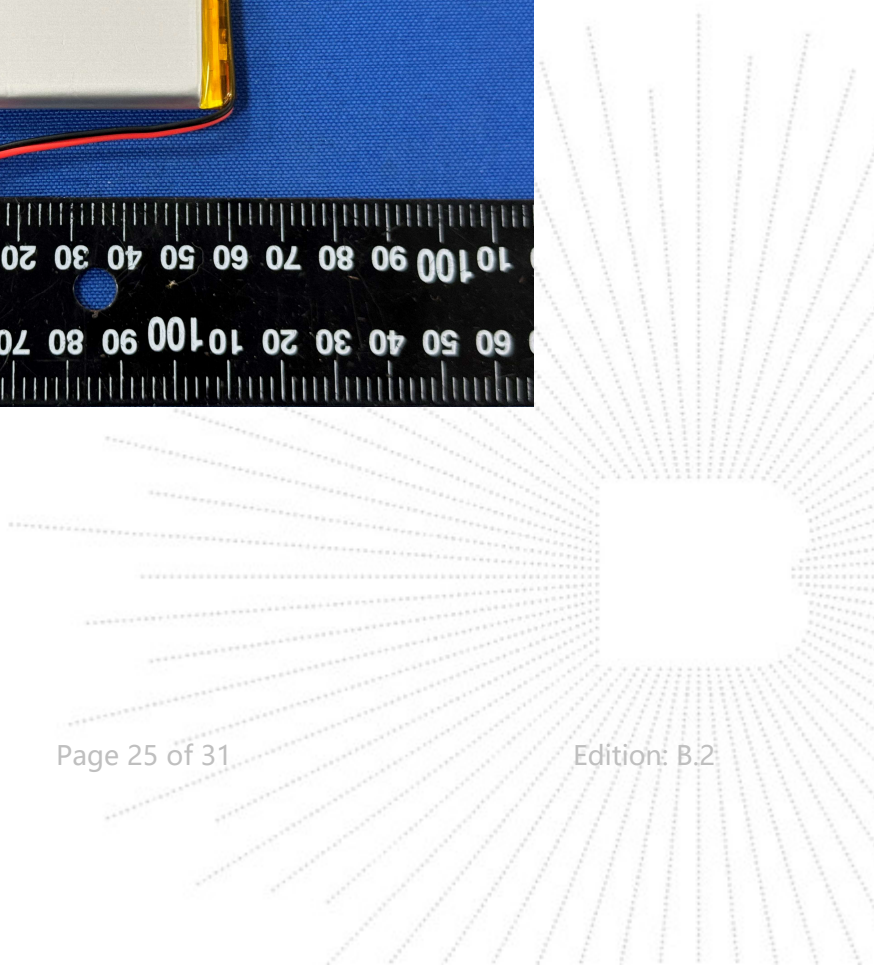
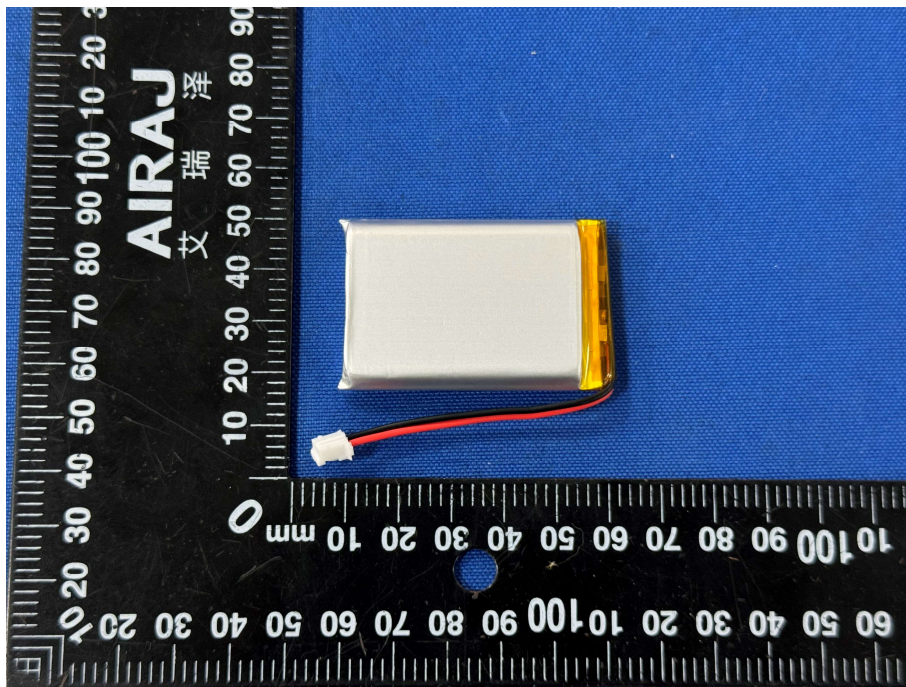
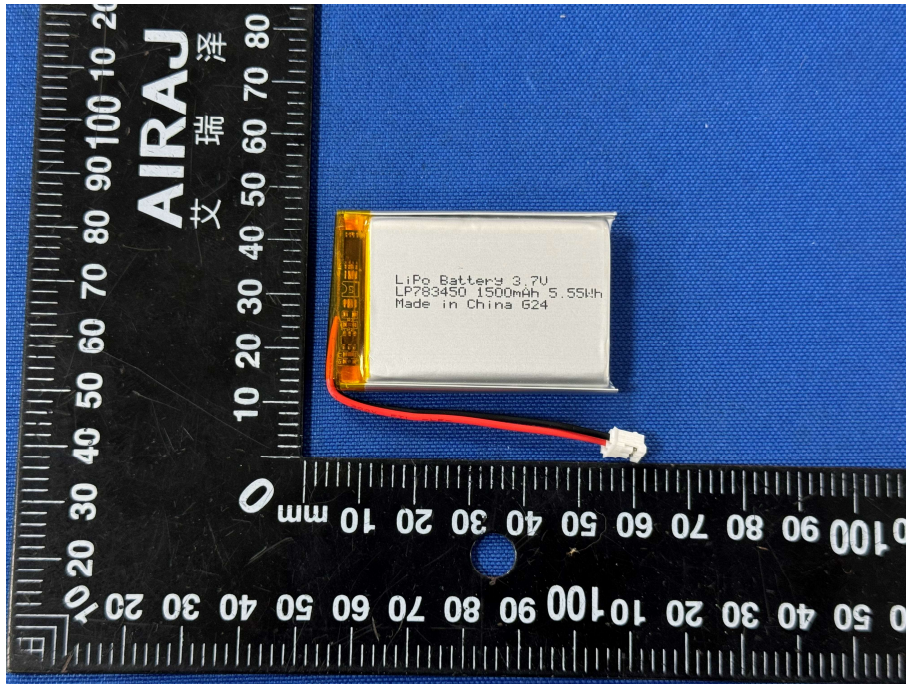

ID 02- Internal cell photograph

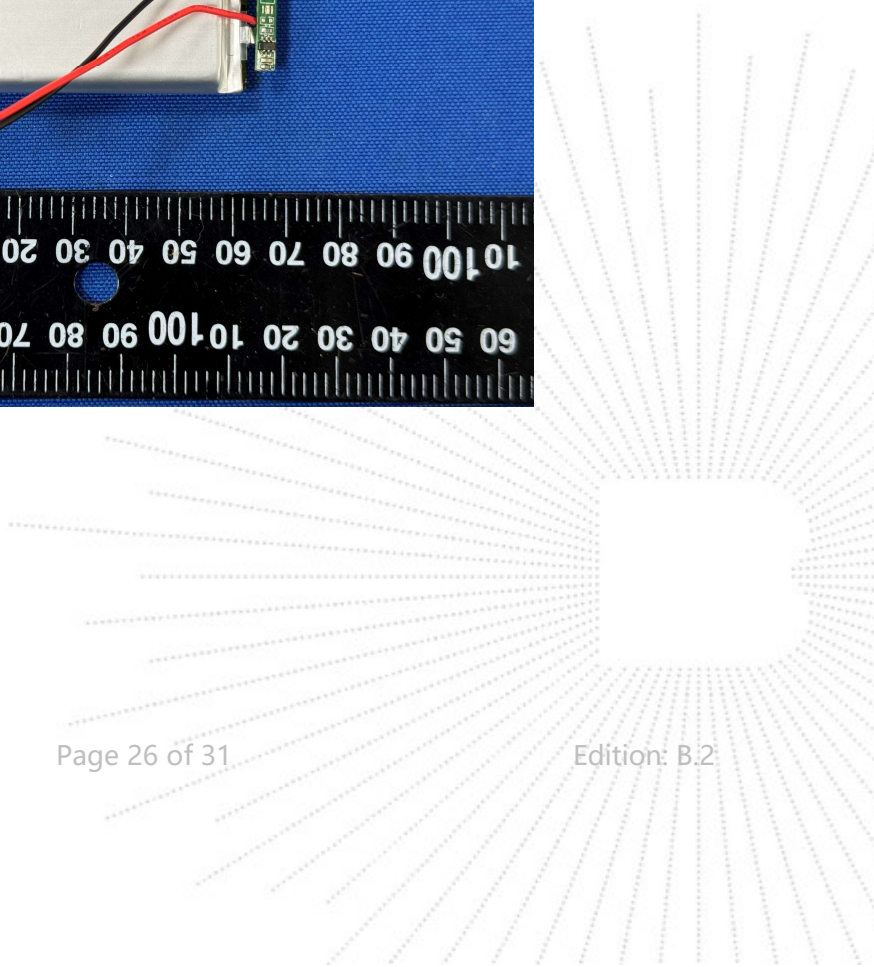
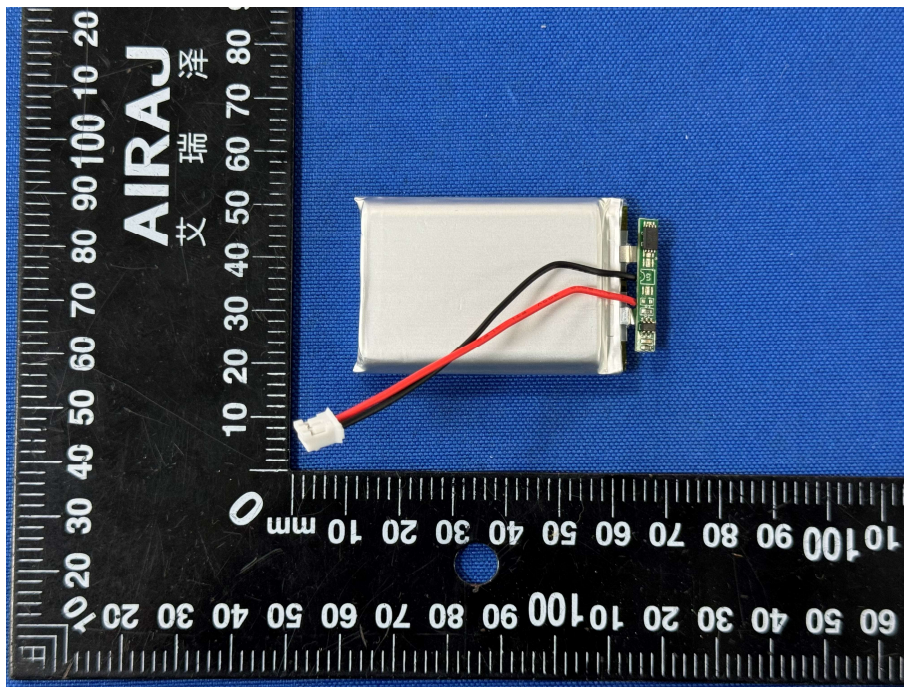
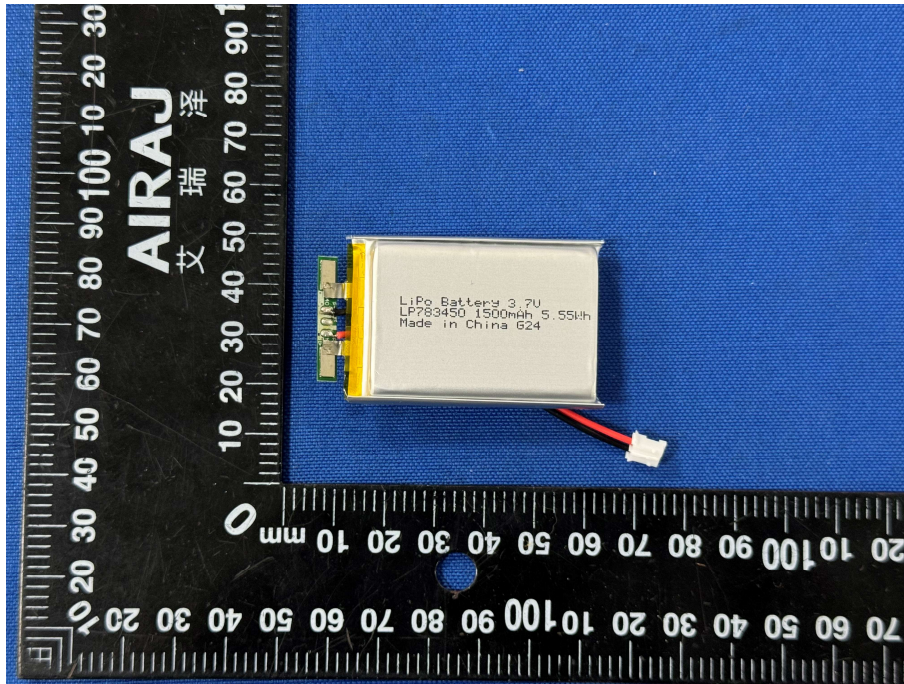



ID 03- Cell photograph

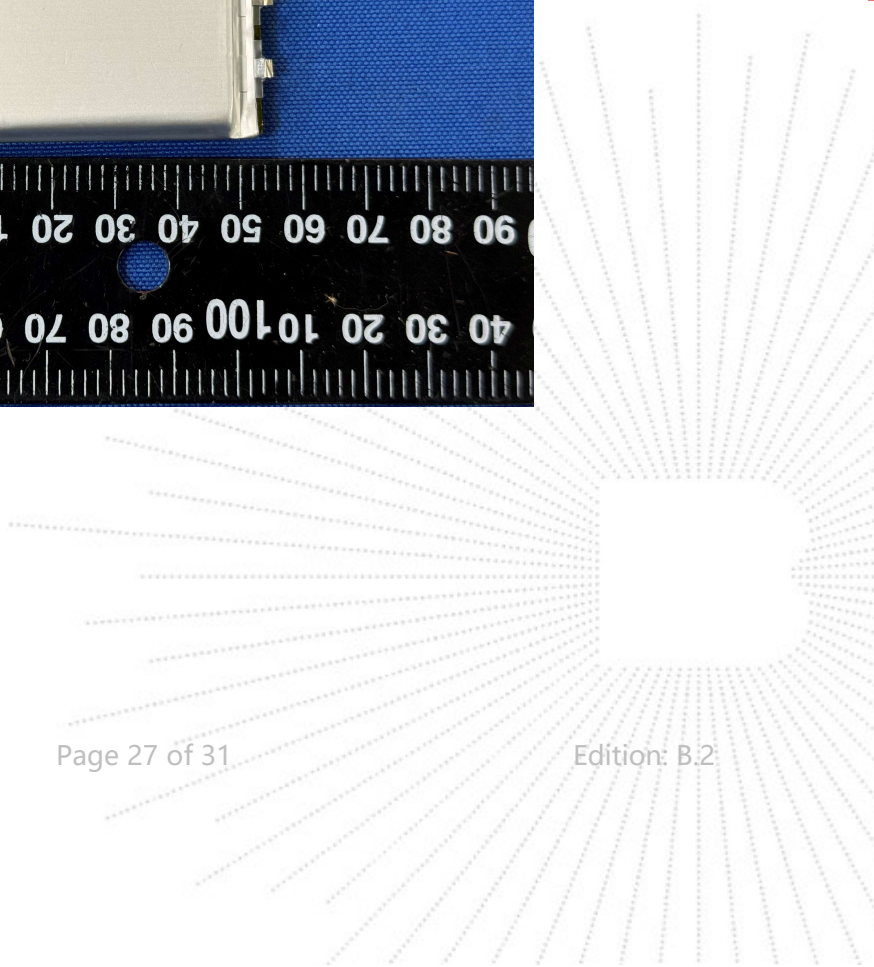
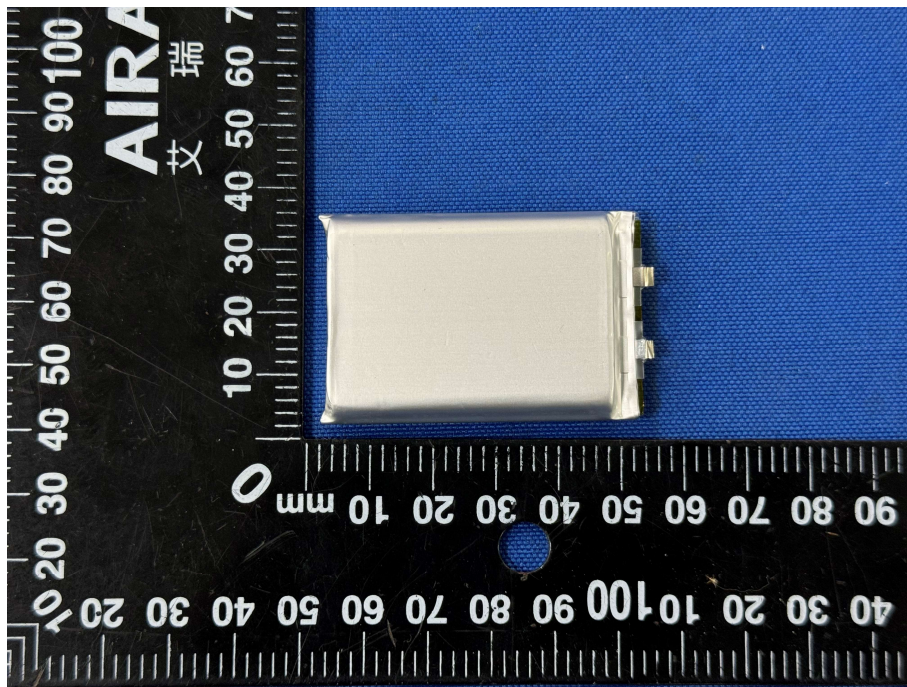
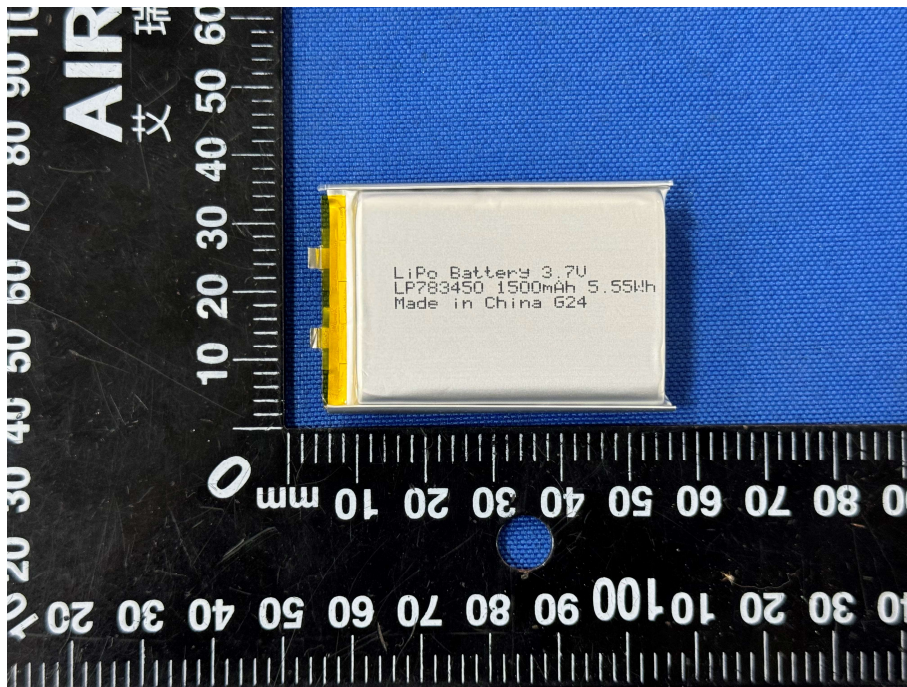

ID 04- PWB photograph

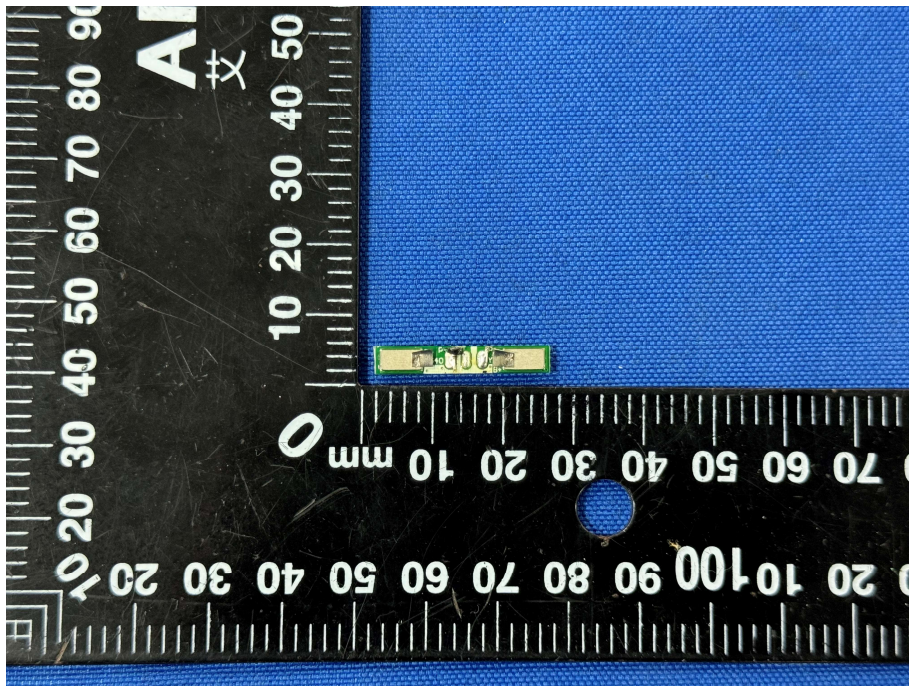
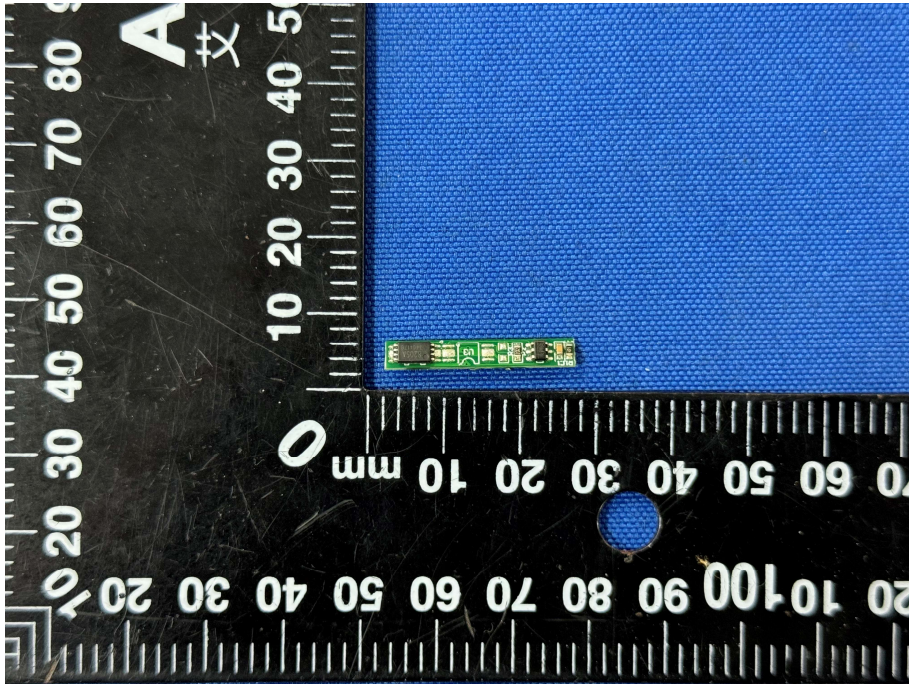

CT  
PROC  
ort

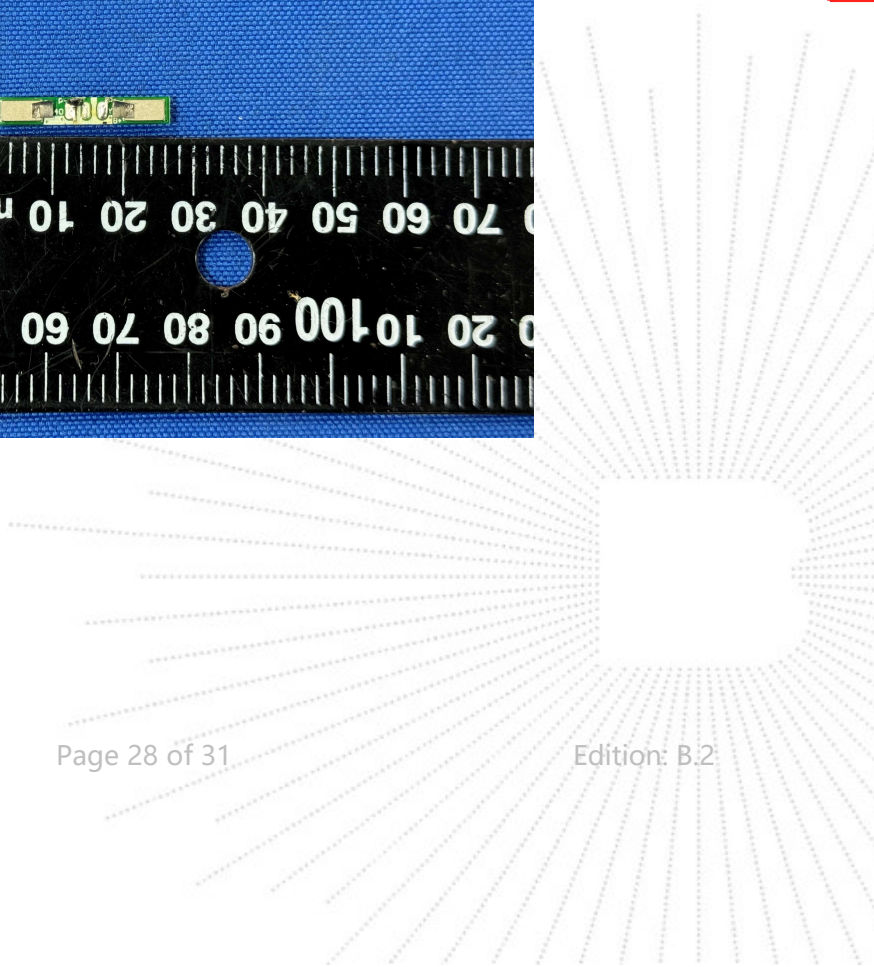



ID 05- Dimension drawing

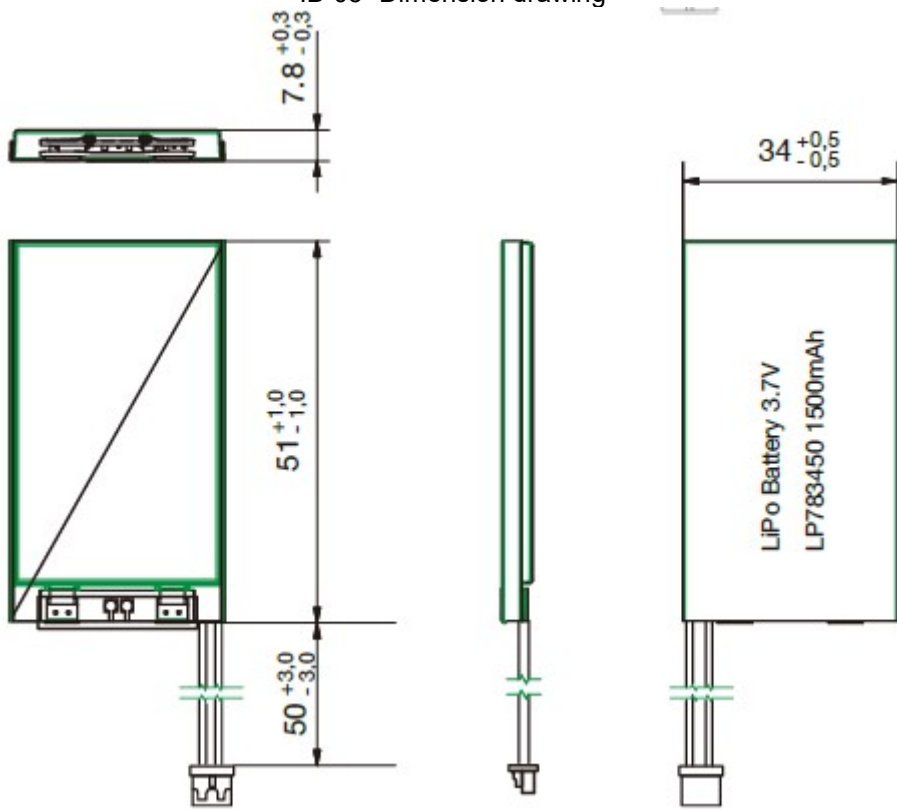

Battery (Unit: mm)

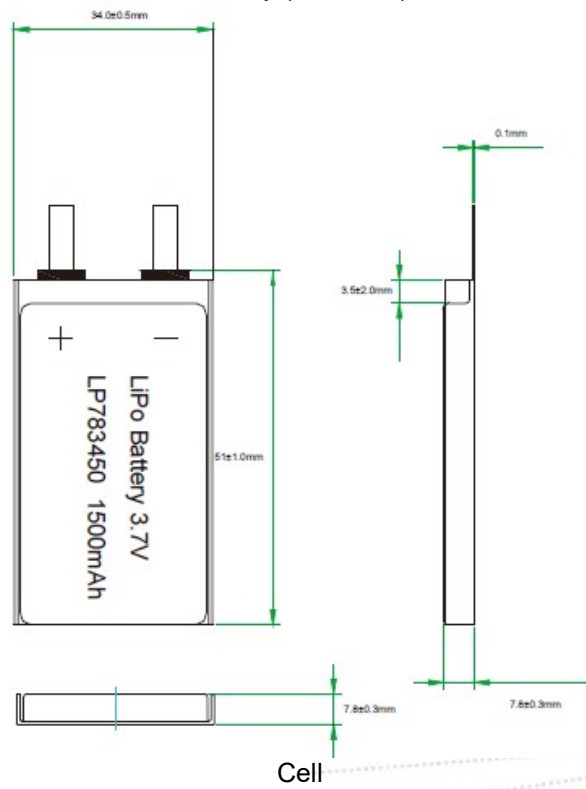

Cell

RES  
FO  
VE  
seal

## ID 06- Circuit diagram and layout

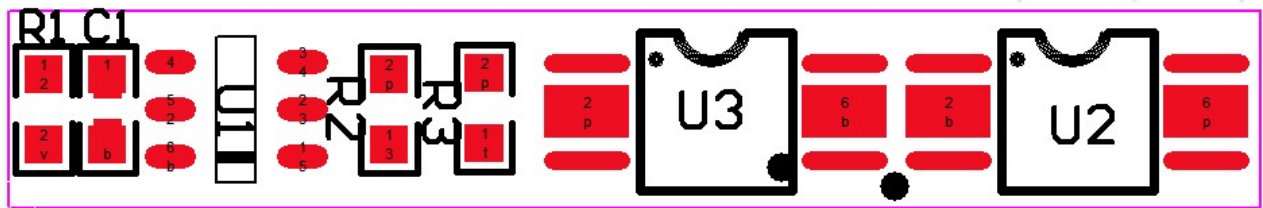
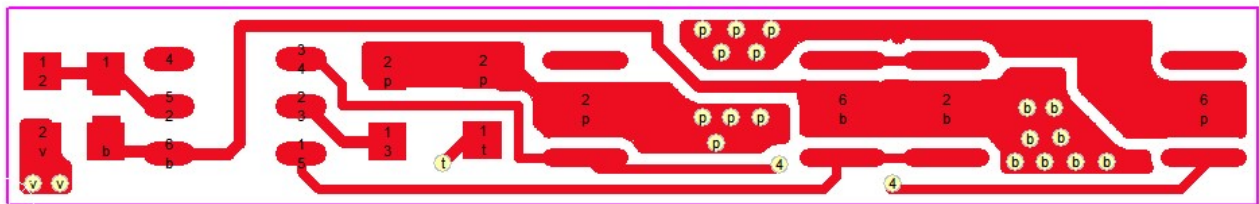
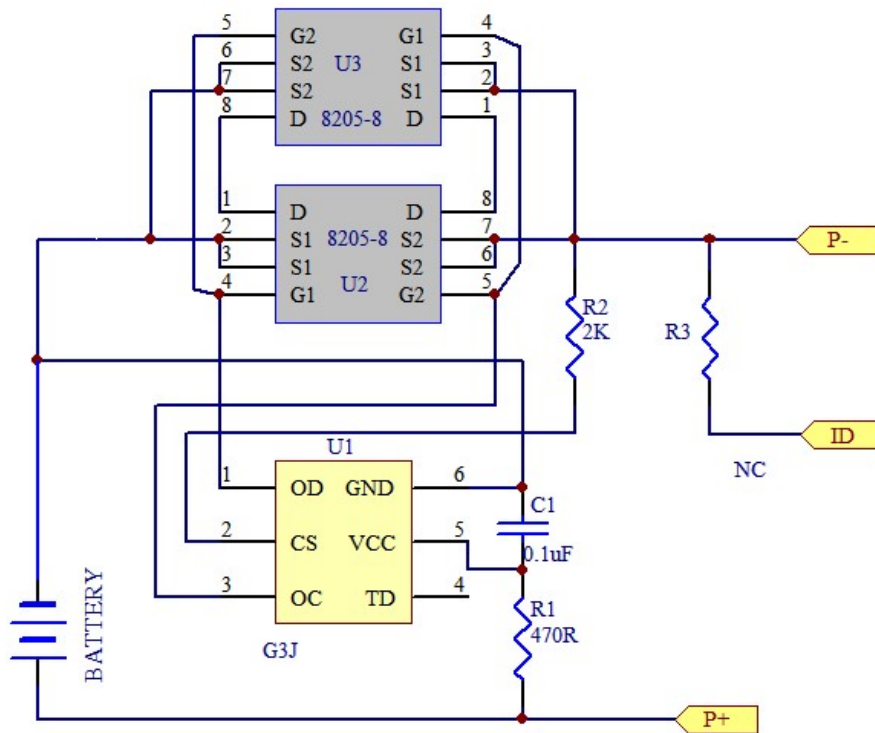

**STATEMENT**

1. The equipment lists are traceable to the national reference standards.
2. The test report can not be partially copied unless prior written approval is issued from our lab.
3. The test report is invalid without the "special seal for inspection and testing".
4. The test report is invalid without the signature of the approver.
5. The test process and test result is only related to the Unit Under Test.
6. Sample information is provided by the client and the laboratory is not responsible for its authenticity.
7. The quality system of our laboratory is in accordance with ISO/IEC17025.
8. If there is any objection to this test report, the client should inform issuing laboratory within 15 days from the date of receiving test report.

**Address:**

1-2/F., Building B, Pengzhou Industrial Park, No.158, Fuyuan 1st Road, Zhancheng, Fuhai Subdistrict, Bao'an District, Shenzhen, Guangdong, China

TEL: 400-788-9558

P.C.: 518103

FAX: 0755-33229357

Website: <http://www.chnbctc.com>

Consultation E-mail: [bctc@bctc-lab.com.cn](mailto:bctc@bctc-lab.com.cn)

Complaint/Advice E-mail: [advice@bctc-lab.com.cn](mailto:advice@bctc-lab.com.cn)

\*\*\*\*\* END \*\*\*\*\*

CO., LTD.

