

LB11685AV

Monolithic Digital IC 3-phase Sensor Less Motor Driver

Overview

The LB11685AV is a three-phase full-wave current-linear-drive motor driver IC. It adopts a sensor less control system without the use of a Hall Effect device. For quieter operation, the LB11685AV features a current soft switching circuit and be optimal for driving the cooling fan motors used in refrigerators, etc.

Functions

- Three-phase Full-wave Linear Drive (Hall Sensor-less Method)
- Built-in Current Limiter Circuit
- Built-in Three-phase Output Voltage Control Circuit
- Built-in Motor Lock Protection Circuit
- Motor Lock Protection Detection Output
- FG Output Made by Back EMF
- Built-in Thermal Shut Down Circuit
- Beat Lock Prevention Circuit

Specifications

MAXIMUM RATINGS ($T_A = 25^\circ\text{C}$)

Parameter	Symbol	Conditions	Ratings	Unit
Maximum Supply Voltage	V_{CC} max		19	V
Input Applied Voltage	V_{IN} max		-0.3 to $V_{CC} + 0.3$	V
Maximum Output Current	I_O max (Note 1)		1.2	A
Allowable Power Dissipation	P_d max	Mounted on a board (Note 2)	1.05	W
Operating Temperature	T_{opr}		-40 to $+85$	$^\circ\text{C}$
Storage Temperature	T_{stg}		-55 to $+150$	$^\circ\text{C}$
Junction Temperature	T_j max		150	$^\circ\text{C}$

Stresses exceeding those listed in the Maximum Ratings table may damage the device. If any of these limits are exceeded, device functionality should not be assumed, damage may occur and reliability may be affected.

1. The I_O is a peak value of motor-current.
2. Specified board: 76.1 mm \times 114.3 mm \times 1.6 mm, glass epoxy board.

CAUTION: Absolute maximum ratings represent the value which cannot be exceeded for any length of time.

CAUTION: Even when the device is used within the range of absolute maximum ratings, as a result of continuous usage under high temperature, high current, high voltage, or drastic temperature change, the reliability of the IC may be degraded. Please contact us for the further details.



ON Semiconductor®

www.onsemi.com

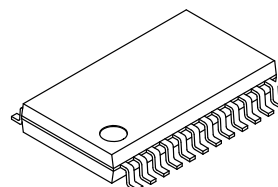

SSOP24J
CASE 565AS

MARKING DIAGRAM

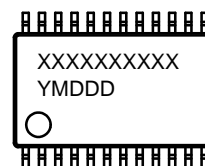

XXXXX = Specific Device Code
Y = Year
M = Month
DDD = Additional Traceability Data

PIN ASSIGNMENT

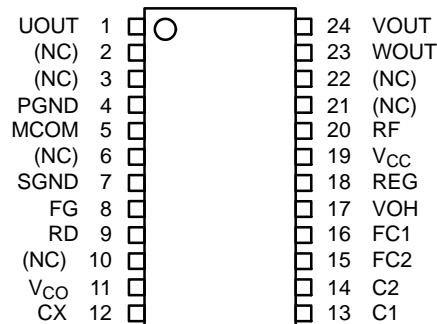

ORDERING INFORMATION

See detailed ordering and shipping information on page 7 of this data sheet.

LB11685AV

RECOMMENDED OPERATING CONDITIONS ($T_A = 25^\circ\text{C}$)

Symbol	Parameter	Conditions	Ratings	Unit
V_{CC}	Recommended Supply Voltage		12.0	V
$V_{CC\ op}$	Operating Supply Voltage		4.5 to 18.0	V

Functional operation above the stresses listed in the Recommended Operating Ranges is not implied. Extended exposure to stresses beyond the Recommended Operating Ranges limits may affect device reliability.

ELECTRICAL CHARACTERISTICS ($T_C = 25^\circ\text{C}$ unless otherwise noted)

Symbol	Parameter	Conditions	Min	Typ	Max	Unit
I_{CC}	Supply Current	$FC1 = FC2 = 0\ \text{V}$	5	10	20	mA
VREG	Internal Regulate Voltage		3.0	3.3	3.6	V
VOSOUR	Output Voltage (Source)	$I_O = 0.8\ \text{A}$ (Note 5)		1.3	1.7	V
VOSINK	Output Voltage (Sink)	$I_O = 0.8\ \text{A}$ (Note 5)		0.5	1.3	V
VOLIM	Current Limiter		0.268	0.300	0.332	V
VINCOM	MCOM Pin Common-input Voltage Range		0		$V_{CC} - 2$	V
ICOM+	MCOM Pin Source Current for Hysteresis	$MCOM = 7\ \text{V}$	30		80	μA
ICOM-	MCOM Pin Sink Current for Hysteresis	$MCOM = 7\ \text{V}$	30		80	μA
RTCOM	MCOM Pin Hysteresis Current Ratio	$RTCOM = ICOM+ / ICOM-$	0.6		1.4	
I_{VCO}	VCO Input Bias Current	$V_{CO} = 2.3\ \text{V}$			0.2	μA
$f_{VCO\ min}$	VCO Oscillation Minimum Frequency	$V_{CO} = 2.1\ \text{V}$, $CX = 0.015\ \mu\text{F}$ Design target (Note 4)		930		Hz
$f_{VCO\ max}$	VCO Oscillation Maximum Frequency	$V_{CO} = 2.7\ \text{V}$, $CX = 0.015\ \mu\text{F}$ Design target (Note 4)		8.6		kHz
I_{CX}	CX Charge/Discharge Current	$V_{CO} = 2.5\ \text{V}$, $CX = 1.6\ \text{V}$	70	100	140	μA
ΔV_{CX}	CX Hysteresis Voltage		0.35	0.55	0.75	
IC1(2)+	C1 (C2) Charge Current	$V_{CO} = 2.5\ \text{V}$, $C1(2) = 1.3\ \text{V}$	12	20	28	μA
IC1(2)-	C1 (C2) Discharge Current	$V_{CO} = 2.5\ \text{V}$, $C1(2) = 1.3\ \text{V}$	12	20	28	μA
RTC1(2)	C1 (C2) Charge/Discharge Current Ratio	$RTC1(2) = IC1(2)+ / IC1(2)-$	0.8	1.0	1.2	
RTCCHG	C1/C2 Charge Current Ratio	$RTCCHG = IC1+ / IC2+$	0.8	1.0	1.2	
RTCDIS	C1/C2 Discharge Current Ratio	$RTCDIS = IC1- / IC2-$	0.8	1.0	1.2	
VCW1(2)	C1 (C2) Cramp Voltage Width		1.0	1.3	1.6	V
VFGL	FG Output Low Level Voltage	$IFG = 3\ \text{mA}$			0.5	V
VRDL	RD Output Low Level Voltage	$IRD = 3\ \text{mA}$			0.5	V
TTSD	Thermal Shut Down Operating Temperature (Note 3)	Junction temperature Design target (Note 4)	150	180		$^\circ\text{C}$
ΔTTSD	Thermal Shut Down Hysteresis Temperature (Note 3)	Junction temperature Design target (Note 4)		15		$^\circ\text{C}$

Product parametric performance is indicated in the Electrical Characteristics for the listed test conditions, unless otherwise noted. Product performance may not be indicated by the Electrical Characteristics if operated under different conditions.

3. The thermal shut down circuit is built-in for protection from damage of IC. But its operation is out of T_{opr} . Design thermal calculation at normal operation.

4. Design target value and no measurement is made.

5. The I_O is a peak value of motor-current.

LB11685AV

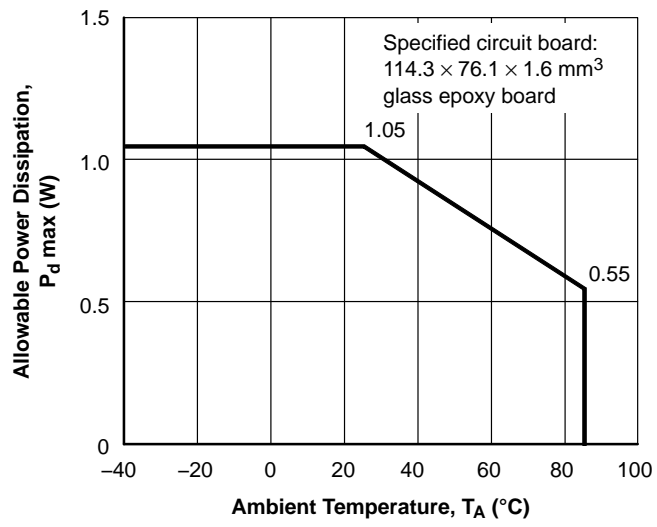

Figure 1. P_d max – T_A

LB11685AV

BLOCK DIAGRAM

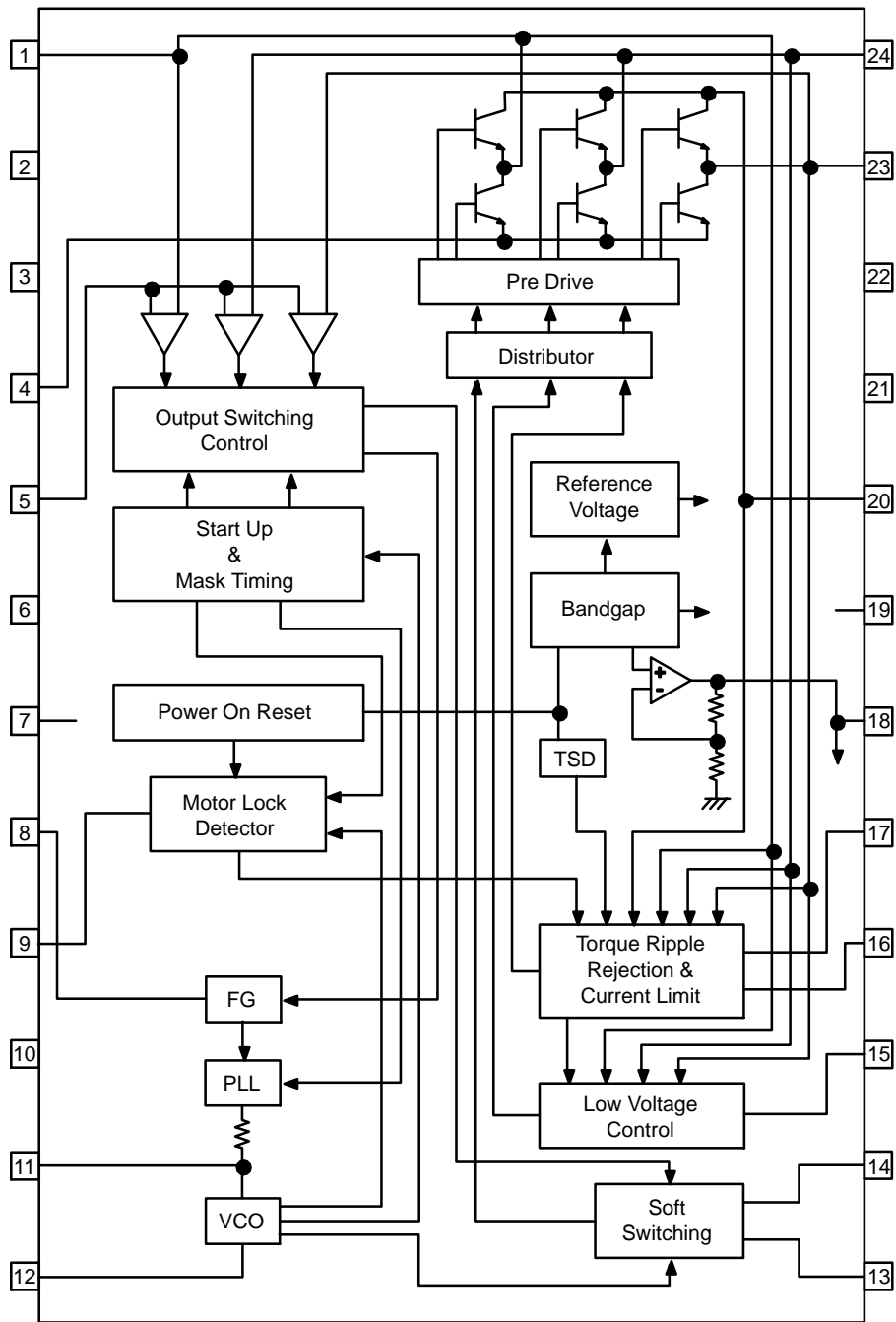

Figure 2. Block Diagram

LB11685AV

PIN FUNCTION

PIN FUNCTION

Pin No.	Pin Name	Function	Equivalent Circuit
1 23 24	UOUT WOUT VOUT	Each output pin of three phases.	
4	PGND	GND pin in the output part. This pin is connected to GND. The SGND pin is also connected to GND	
20	RF	Pin to detect output current. By connecting a resistor between this pin and V _{CC} , the output current is detected as a voltage. The current limiter is operated by this voltage.	
5	MCOM	Motor coil midpoint input pin. The coil voltage waveform is detected based on this voltage.	
7	SGND	Ground pin (except the output part) This pin is connected to GND. The PGND pin is also connected to GND.	
8	FG	FG out made by back EMF pin. It synchronizes FG out with inverted V-phase. When don't use this function, open this pin.	
9	RD	Motor lock protection detection output pin. Output with L during rotation of motor. Open during lock protection of motor (High-impedance). When don't use this function, open this pin.	
11	VCO	PLL output pin and VCO input pin. To stabilize PLL output, connect a capacitor between this pin and GND.	

LB11685AV

PIN FUNCTION (continued)

Pin No.	Pin Name	Function	Equivalent Circuit
12	CX	VCO oscillation output pin. Operation frequency range and minimum frequency are determined by the capacity of the capacitor connected to this pin.	
13 14	C1 C2	Soft switching adjustment pin. The triangular wave from is form formed by connecting a capacitor with this pin. And, the switching of three-phase output is adjusted by the slope.	
15	FC2	Frequency characteristic correction pin 2. To suppress the oscillation of control system closed loop of sink-side, connect a capacitor between this pin and GND.	
16	FC1	Frequency characteristic correction pin 1. To suppress the oscillation of control system closed loop of source-side, connect a capacitor between this pin and GND.	
17	VOH	Three-phase output high level output pin. To stabilize the output voltage of this pin, connect a capacitor between this pin and the VCC pin.	
18	VREG	DC voltage (3.3 V) output pin. Connect a capacitor between this pin and GND for stabilization.	
19	VCC	Pin to supply power-supply voltage. To curb the influence of ripple and noise. The voltage should be stabilized.	

LB11685AV

APPLICATION CIRCUIT EXAMPLE

* Each fixed number in the following Figure 3, is the referential value.

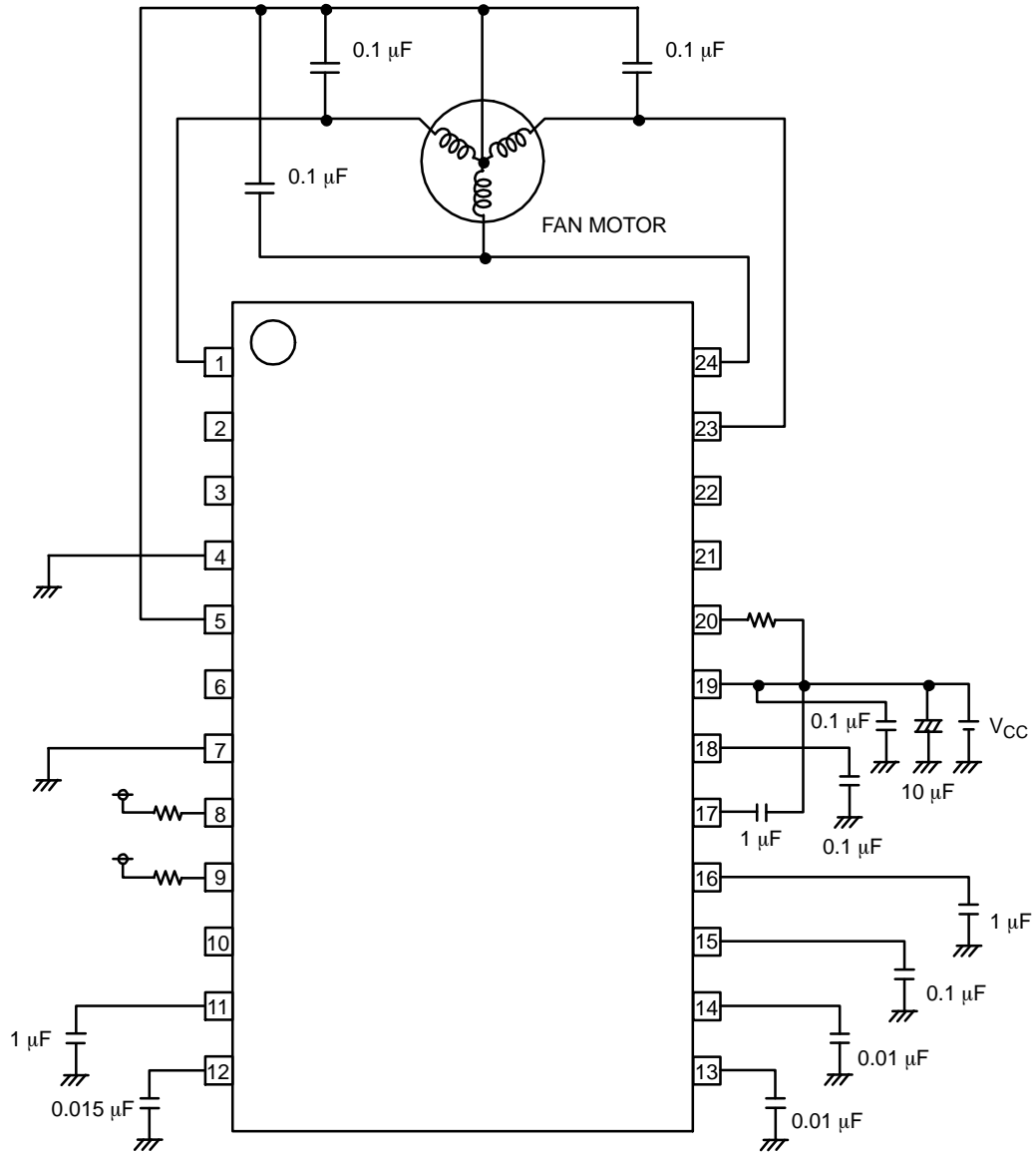

Figure 3. Application Circuit Example

ORDERING INFORMATION

Device	Package	Wire Bond	Shipping† (Qty / Packing)
LB11685AV-TLM-H	SSOP24J (275mil) (Pb-Free / Halogen Free)	Au-wire	2000 / Tape & Reel
LB11685AV-W-AH	SSOP24J (275mil) (Pb-Free / Halogen Free)	Cu-wire	2000 / Tape & Reel

†For information on tape and reel specifications, including part orientation and tape sizes, please refer to our Tape and Reel Packaging Specifications Brochure, [BRD8011/D](#).

MECHANICAL CASE OUTLINE

PACKAGE DIMENSIONS

ON Semiconductor®



SSOP24J (275mil)
CASE 565AS
ISSUE A

DATE 31 OCT 2013

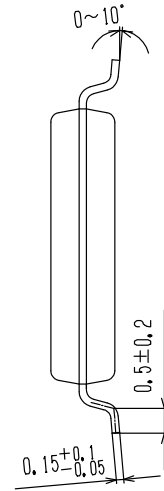
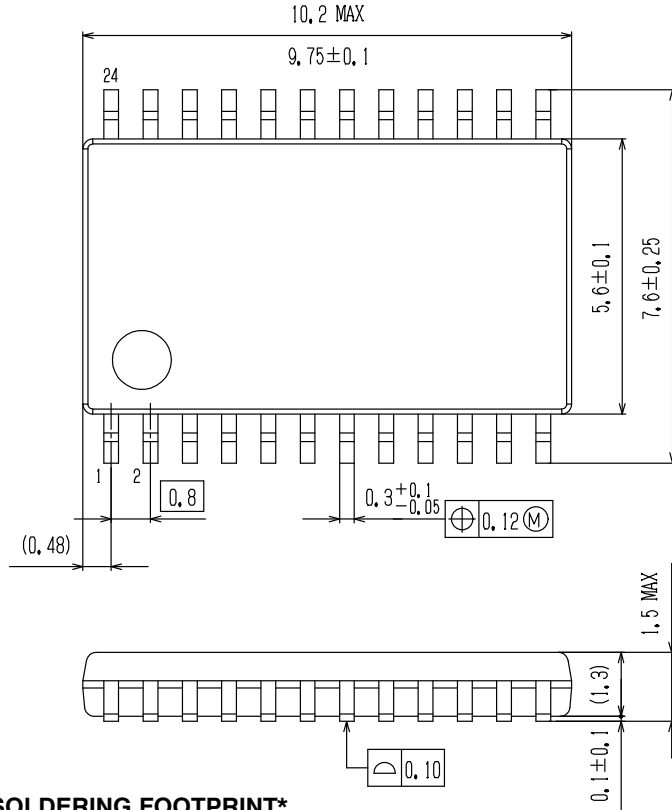
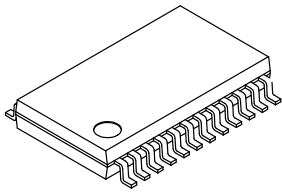

SOLDERING FOOTPRINT*

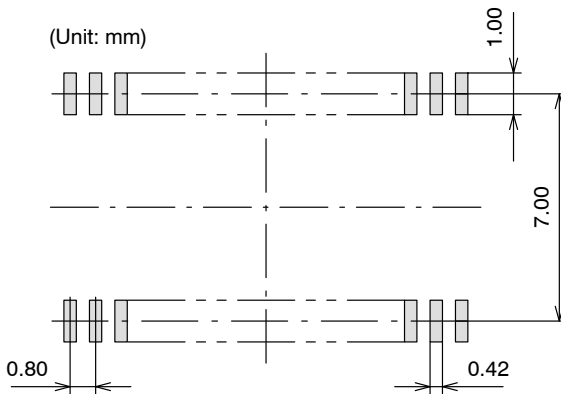

GENERIC MARKING DIAGRAM*

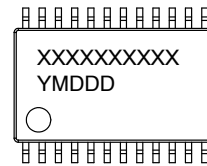

XXXXX = Specific Device Code
 Y = Year
 M = Month
 DDD = Additional Traceability Data

NOTE: The measurements are not to guarantee but for reference only.

*For additional information on our Pb-Free strategy and soldering details, please download the ON Semiconductor Soldering and Mounting Techniques Reference Manual, SOLDERRM/D.

*This information is generic. Please refer to device data sheet for actual part marking. Pb-Free indicator, "G" or microdot "▪", may or may not be present.

DOCUMENT NUMBER:	98AON66070E	Electronic versions are uncontrolled except when accessed directly from the Document Repository. Printed versions are uncontrolled except when stamped "CONTROLLED COPY" in red.
DESCRIPTION:	SSOP24J (275MIL)	PAGE 1 OF 1

ON Semiconductor and are trademarks of Semiconductor Components Industries, LLC dba ON Semiconductor or its subsidiaries in the United States and/or other countries. ON Semiconductor reserves the right to make changes without further notice to any products herein. ON Semiconductor makes no warranty, representation or guarantee regarding the suitability of its products for any particular purpose, nor does ON Semiconductor assume any liability arising out of the application or use of any product or circuit, and specifically disclaims any and all liability, including without limitation special, consequential or incidental damages. ON Semiconductor does not convey any license under its patent rights nor the rights of others.

ON Semiconductor and  are trademarks of Semiconductor Components Industries, LLC dba ON Semiconductor or its subsidiaries in the United States and/or other countries. ON Semiconductor owns the rights to a number of patents, trademarks, copyrights, trade secrets, and other intellectual property. A listing of ON Semiconductor's product/patent coverage may be accessed at www.onsemi.com/site/pdf/Patent-Marking.pdf. ON Semiconductor reserves the right to make changes without further notice to any products herein. ON Semiconductor makes no warranty, representation or guarantee regarding the suitability of its products for any particular purpose, nor does ON Semiconductor assume any liability arising out of the application or use of any product or circuit, and specifically disclaims any and all liability, including without limitation special, consequential or incidental damages. Buyer is responsible for its products and applications using ON Semiconductor products, including compliance with all laws, regulations and safety requirements or standards, regardless of any support or applications information provided by ON Semiconductor. "Typical" parameters which may be provided in ON Semiconductor data sheets and/or specifications can and do vary in different applications and actual performance may vary over time. All operating parameters, including "Typicals" must be validated for each customer application by customer's technical experts. ON Semiconductor does not convey any license under its patent rights nor the rights of others. ON Semiconductor products are not designed, intended, or authorized for use as a critical component in life support systems or any FDA Class 3 medical devices or medical devices with a same or similar classification in a foreign jurisdiction or any devices intended for implantation in the human body. Should Buyer purchase or use ON Semiconductor products for any such unintended or unauthorized application, Buyer shall indemnify and hold ON Semiconductor and its officers, employees, subsidiaries, affiliates, and distributors harmless against all claims, costs, damages, and expenses, and reasonable attorney fees arising out of, directly or indirectly, any claim of personal injury or death associated with such unintended or unauthorized use, even if such claim alleges that ON Semiconductor was negligent regarding the design or manufacture of the part. ON Semiconductor is an Equal Opportunity/Affirmative Action Employer. This literature is subject to all applicable copyright laws and is not for resale in any manner.

PUBLICATION ORDERING INFORMATION

LITERATURE FULFILLMENT:

Email Requests to: orderlit@onsemi.com

ON Semiconductor Website: www.onsemi.com

TECHNICAL SUPPORT

North American Technical Support:
Voice Mail: 1 800-282-9855 Toll Free USA/Canada
Phone: 011 421 33 790 2910

Europe, Middle East and Africa Technical Support:

Phone: 00421 33 790 2910

For additional information, please contact your local Sales Representative

Mouser Electronics

Authorized Distributor

Click to View Pricing, Inventory, Delivery & Lifecycle Information:

[ON Semiconductor:](#)

[LB11685AV-TLM-H](#) [LB11685AV-MPB-H](#) [LB11685AV-W-AH](#)