



# **E19-915M30S User Manual**

**SX1276 915MHz 1W SMD Wireless Module**



# Contents

<b>Disclaimer.....</b>	<b>2</b>
<b>1. Overview.....</b>	<b>3</b>
1.1 Brief introduction.....	3
1.2 Features.....	3
<b>2.Specification and parameter.....</b>	<b>4</b>
2.1 Limit parameter.....	4
2.2 Operating parameter.....	4
<b>3.Size and pin definition.....</b>	<b>5</b>
<b>4. Basic operation.....</b>	<b>6</b>
4.1 Hardware design.....	6
4.2 Software editing.....	7
5.Basic application.....	8
5.1 Basic circuit diagram.....	8
<b>6.FAQ.....</b>	<b>8</b>
6.1 Communication range is too short.....	8
6.2 Module is easy to damage.....	9
6.3 BER(Bit Error Rate) is high.....	9
<b>7.Production guidance.....</b>	<b>9</b>
7.1 Reflow soldering temperature.....	9
7.2 Reflow soldering curve.....	10
<b>8.E19 Series.....</b>	<b>10</b>
<b>9.Antenna guidance.....</b>	<b>11</b>
9.1 Antenna recommendation.....	11
<b>10. Package for batch order.....</b>	<b>12</b>
<b>Revision history.....</b>	<b>12</b>
<b>About us.....</b>	<b>12</b>

## **Disclaimer**

EBYTE reserves all rights to this document and the information contained herein. Products, names, logos and designs described herein may in whole or in part be subject to intellectual property rights. Reproduction, use, modification or disclosure to third parties of this document or any part thereof without the express permission of EBYTE is strictly prohibited.

The information contained herein is provided “as is” and EBYTE assumes no liability for the use of the information. No warranty, either express or implied, is given, including but not limited, with respect to the accuracy, correctness, reliability and fitness for a particular purpose of the information. This document may be revised by EBYTE at any time. For most recent documents, visit [www.ebyte.com](http://www.ebyte.com).

# 1. Overview

## 1.1 Brief introduction

E19-915M30S is 1W SMD wireless module working at 915MHz, developed based on chip SX1276 from Semtech.

Due to the use of the imported SX1276 as the core of the module, with PA and LNA its sensitivity and stability are largely improved when tx power is 1W. Compared with the FSK、GFSK products, it has made great progress in anti-interference ability and communication distance. The module is aimed at smart home, wireless meter reading, scientific research and medical, and medium and long distance wireless communication equipment. Since RF performance and component selection are in accordance with industrial standards, and the product has obtained FCC, CE, RoHS and other international authoritative certification reports, users do not need to worry about its performance. High precision 32MHz crystal is used.



Since the module is a pure RF transceiver module, you need to use the MCU driver or a dedicated SPI debug tool.

## 1.2 Features

- Communication distance tested is up to 10km ;
- Maximum transmission power of 1W, software multi-level adjustable ;
- Support the global license-free ISM 915MHz band ;
- Support air data rate of 0.018kbps~37.5kbp in LoRa™ ;
- The maximum data transmission rate 300kpbs in FSK mode ;
- Support multiple modulation methods, LoRa™ /FSK/GFSK/MSK/GMSK/OOK ;
- Large capacity FIFO, supports 256Byte data buffer ;
- Support 2.5V~5.5V power supply, power supply over 5.0V can guarantee the best performance ;
- Industrial grade standard design, support -40 ~ 85 °C for working over a long time ;
- IPEX and Stamp hole, good for secondary development and integration.

## 1.3 Application

- Home security alarm and remote keyless entry ;
- Smart home and industrial sensors ;
- Wireless alarm security system ;
- Building automation solutions ;
- Wireless industrial-grade remote control ;
- Health care products ;
- Advanced Meter Reading Architecture(AMI) ;
- Automotive industry applications.

## 2.Specification and parameter

### 2.1 Limit parameter

Main parameter	Performance		Remark
	Min.	Max.	
Power supply (V)	0	5.5	Voltage over 5.5V will cause permanent damage to module
Blocking power (dBm)	-	10	Chances of burn is slim when modules are used in short distance
Operating temperature (°C)	-40	85	/

### 2.2 Operating parameter

Main parameter		Performance			Remark	
		Min.	Typ.	Max.		
Operating voltage (V)		3.3	5.0	5.5	≥5.0 V ensures output power	
Communication level (V)			3.3		For 5V TTL, it may be at risk of burning down	
Operating temperature (°C)		-40	-	85	Industrial design	
Operating frequency (MHz)		900	915	931	Support ISM band	
Power consumption	TX current (mA)		630		Instant power consumption	
	RX current (mA)		23			
	Sleep current (μA)		3.0		Software is shut down	
Max Tx power (dBm)		28.5	30	30		
Receiving sensitivity (dBm)		-146	-148	-150	Sensitivity test conditions : air data rate: 0.3 kbps, Coding rate 4/5, Spread Spectrum Factor 12.	
Air data rate (bps)		1.2	-	300	Kbps	FSK
		0.018	-	37.5	Kbps	LoRa™

Main parameter	Description	Remark
Distance for reference	10000m	Test condition : clear and open area, antenna gain: 5dBi, antenna height: 2.5m, air data rate: 0.3kbps
FIFO	256Byte	Max length transmitted each time
Crystal frequency	32MHz	
Modulation	LoRa™ (recommended)	FSK/GFSK/MSK/GMSK/OOK
Package	SMD	
Connector	1.27mm	
Communication interface	SPI	0-10Mbps
Size	25.0*40.0 mm	
Antenna	Stamp hole/IPX	50 ohm impedance

### 3.Size and pin definition

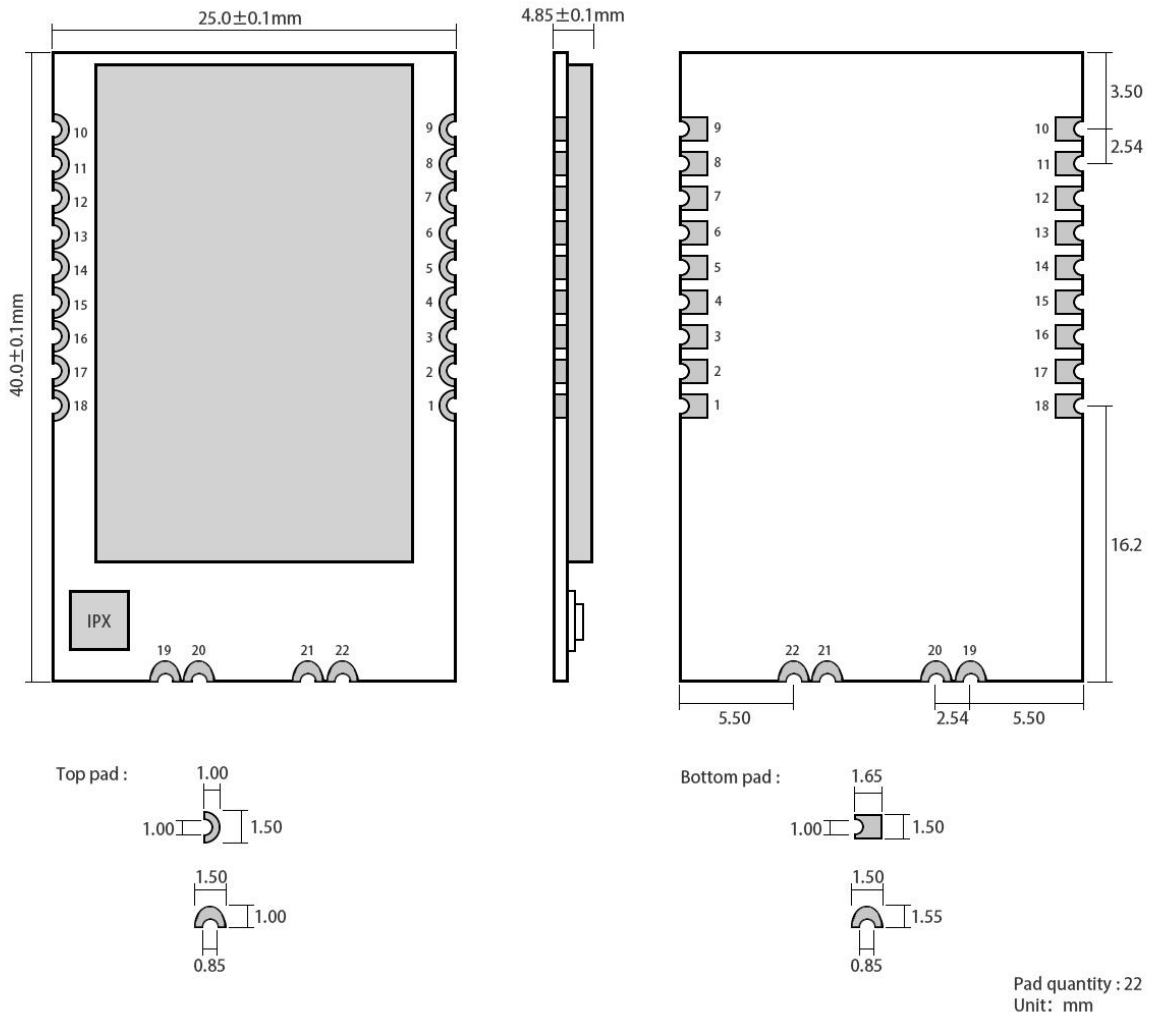

Pin No	Pin item	Pin direction	Pin application
1	GND	-	Ground electrode, connected to the power reference ground
2	DIO5	Input/Output	Configurable IO port ( Please find more on SX1276 datasheet )
3	DIO4	Input/Output	Configurable IO port ( Please find more on SX1276 datasheet )
4	DIO3	Input/Output	Configurable IO port ( Please find more on SX1276 datasheet )
5	DIO2	Input/Output	Configurable IO port ( Please find more on SX1276 datasheet )
6	DIO1	Input/Output	Configurable IO port ( Please find more on SX1276 datasheet )
7	DIO0	Input/Output	Configurable IO port ( Please find more on SX1276 datasheet )
8	RST	Input	Reset
9	GND	-	Ground electrode, connected to the power reference ground.
10	GND	-	Ground electrode, connected to the power reference ground.
11	VCC	-	Power supply: 4.75~5.5V (Ceramic filter capacitor is advised to add)

12	SCK	Input	SPI clock
13	MISO	Output	SPI clock
14	MOSI	Input	SPI clock
15	NSS	Input	Chip select
16	TXEN	Input	Radio frequency switch control, make sure the TXEN pin is in high level, RXEN pin is in low level when transmitting.
17	RXEN	Input	Radio frequency switch control, make sure the TXEN pin is in high level, RXEN pin is in low level when transmitting
18	GND	-	Ground electrode, connected to the power reference ground
19	ANT	-	Antenna
20	GND	-	Ground electrode, connected to the power reference ground
21	GND	-	Ground electrode, connected to the power reference ground
22	GND	-	Ground electrode, connected to the power reference ground

## 4. Basic operation

### 4.1 Hardware design

- It is recommended to use a DC stabilized power supply. The power supply ripple factor is as small as possible, and the module needs to be reliably grounded. ;
- Please pay attention to the correct connection of the positive and negative poles of the power supply. Reverse connection may cause permanent damage to the module ;
- Please check the power supply to ensure it is within the recommended voltage otherwise when it exceeds the maximum value the module will be permanently damaged ;
- Please check the stability of the power supply, the voltage can not be fluctuated frequently ;
- When designing the power supply circuit for the module, it is often recommended to reserve more than 30% of the margin, so the whole machine is beneficial for long-term stable operation. ;
- The module should be as far away as possible from the power supply, transformers, high-frequency wiring and other parts with large electromagnetic interference. ;
- High-frequency digital routing, high-frequency analog routing, and power routing must be avoided under the module. If it is necessary to pass through the module, assume that the module is soldered to the Top Layer, and the copper is spread on the Top Layer of the module contact part(well grounded), it must be close to the digital part of the module and routed in the Bottom Layer ;
- Assuming the module is soldered or placed over the Top Layer, it is wrong to randomly route over the Bottom Layer or other layers, which will affect the module's spurs and receiving sensitivity to varying degrees ;
- It is assumed that there are devices with large electromagnetic interference around the module that will greatly affect the performance. It is recommended to keep them away from the module according to the strength of the interference. If necessary, appropriate isolation and shielding can be done ;
- Assume that there are traces with large electromagnetic interference (high-frequency digital, high-frequency analog, power traces) around the module that will greatly affect the performance of the module. It is recommended to stay away from the module according to the strength of the interference.If necessary, appropriate isolation and shielding

can be done.

- If the communication line uses a 5V level, a 1k-5.1k resistor must be connected in series (not recommended, there is still a risk of damage) ;
- Try to stay away from some physical layers such as TTL protocol at 2.4GHz , for example: USB3.0 ;
- The mounting structure of antenna has a great influence on the performance of the module. It is necessary to ensure that the antenna is exposed, preferably vertically upward. When the module is mounted inside the case, use a good antenna extension cable to extend the antenna to the outside ;
- The antenna must not be installed inside the metal case, which will cause the transmission distance to be greatly weakened.

## 4.2 Software editing

- SX1278/SX1276+PA+LNA, same drive way as SX1278/SX1276, user can refer to SX1278/SX1276 datasheet.
- DIO0、DIO1、DIO2、DIO3、DIO4、DIO5 are configurable I/O ports for various application, see more in SX1276 datasheet. It can be floated when not used.
- RST、TXEN、RXEN must be connected,among which RST control chip reset, TXEN, RXEN are for controlling RF switch.
- Make it ground well with large space for grounding and small power ripple. Filter capacitor is necessary and make sure it is close to pin VCC and GND.
- SPI communication rate should not be set too high, usually around 1Mbps.
- In transmitting, set TXEN as high communication level, RXEN pin is low level; In receiving, set RXEN as high communication level,TXEN is low level; Before powering off, set TXEN、RXEN as low level.
- Re-initialize register configuration when the chip is idle for higher stability.



## 5. Basic application

### 5.1 Basic circuit diagram

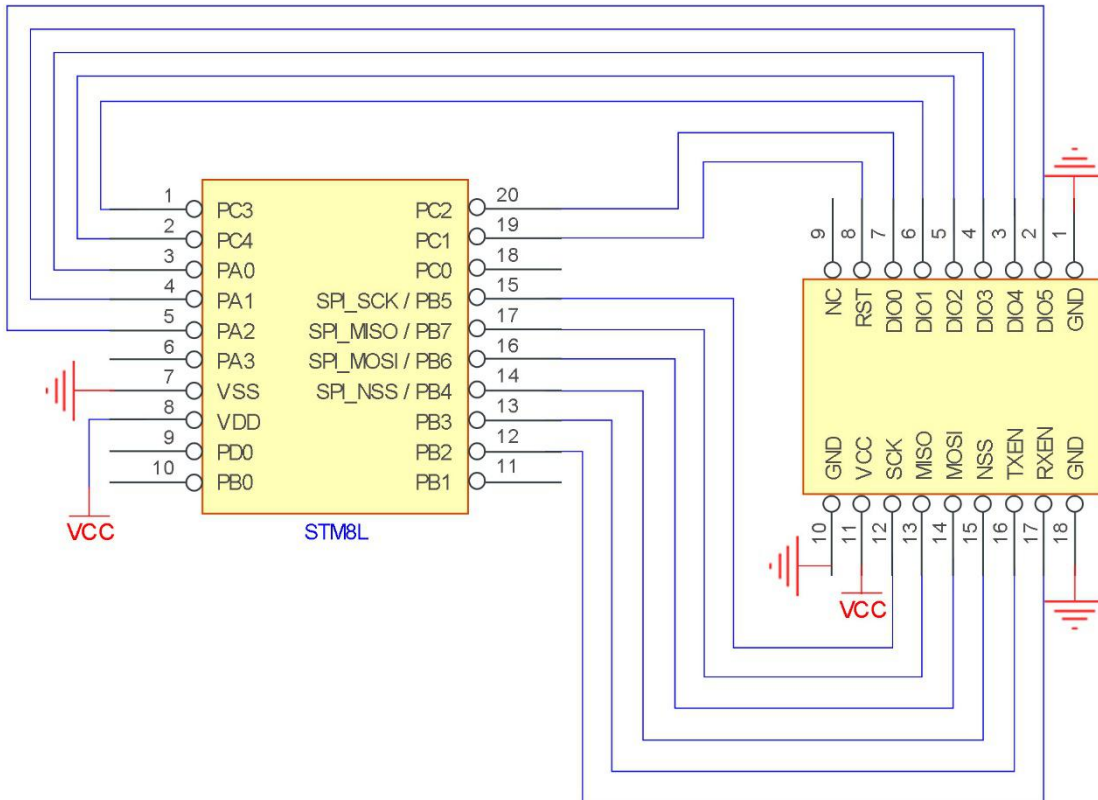

## 6. FAQ

### 6.1 Communication range is too short

- The communication distance will be affected when obstacle exists.
- Data lose rate will be affected by temperature, humidity and co-channel interference.
- The ground will absorb and reflect wireless radio wave, so the performance will be poor when testing near ground.
- Sea water has great ability in absorbing wireless radio wave, so performance will be poor when testing near the sea.
- The signal will be affected when the antenna is near metal object or put in a metal case.
- Power register was set incorrectly, air data rate is set as too high (the higher the air data rate, the shorter the distance).
- The power supply low voltage under room temperature is lower than 2.5V, the lower the voltage, the lower the transmitting power.
- Due to antenna quality or poor matching between antenna and module.

## 6.2 Module is easy to damage

- Please check the power supply source, ensure it is 2.0V~3.6V, voltage higher than 3.6V will damage the module.
- Please check the stability of power source, the voltage cannot fluctuate too much.
- Please make sure antistatic measure are taken when installing and using, high frequency devices have electrostatic susceptibility.
- Please ensure the humidity is within limited range, some parts are sensitive to humidity.
- Please avoid using modules under too high or too low temperature.

## 6.3 BER(Bit Error Rate) is high

- There are co-channel signal interference nearby, please be away from interference sources or modify frequency and channel to avoid interference;
- Poor power supply may cause messy code. Make sure that the power supply is reliable.
- The extension line and feeder quality are poor or too long, so the bit error rate is high;

## 7.Production guidance

### 7.1 Reflow soldering temperature

Profile Feature	Curve characteristics	Sn-Pb Assembly	Pb-Free Assembly
Solder Paste	Solder paste	Sn63/Pb37	Sn96.5/Ag3/Cu0.5
Preheat Temperature min (T <sub>smin</sub> )	Min preheating temp.	100°C	150°C
Preheat temperature max (T <sub>smax</sub> )	Mx preheating temp.	150°C	200°C
Preheat Time (T <sub>smin</sub> to T <sub>smax</sub> )(ts)	Preheating time	60-120 sec	60-120 sec
Average ramp-up rate(T <sub>smax</sub> to T <sub>p</sub> )	Average ramp-up rate	3°C/second max	3°C/second max
Liquidous Temperature (TL)	Liquid phase temp.	183°C	217°C
Time (tL) Maintained Above (TL)	Time below liquid phase line	60-90 sec	30-90 sec
Peak temperature (T <sub>p</sub> )	Peak temp.	220-235°C	230-250°C
Average ramp-down rate (T <sub>p</sub> to T <sub>smax</sub> )	Average ramp-down rate	6°C/second max	6°C/second max
Time 25°C to peak temperature	Time to peak temperature for 25°C	max 6 minutes	max 8 minutes

## 7.2 Reflow soldering curve

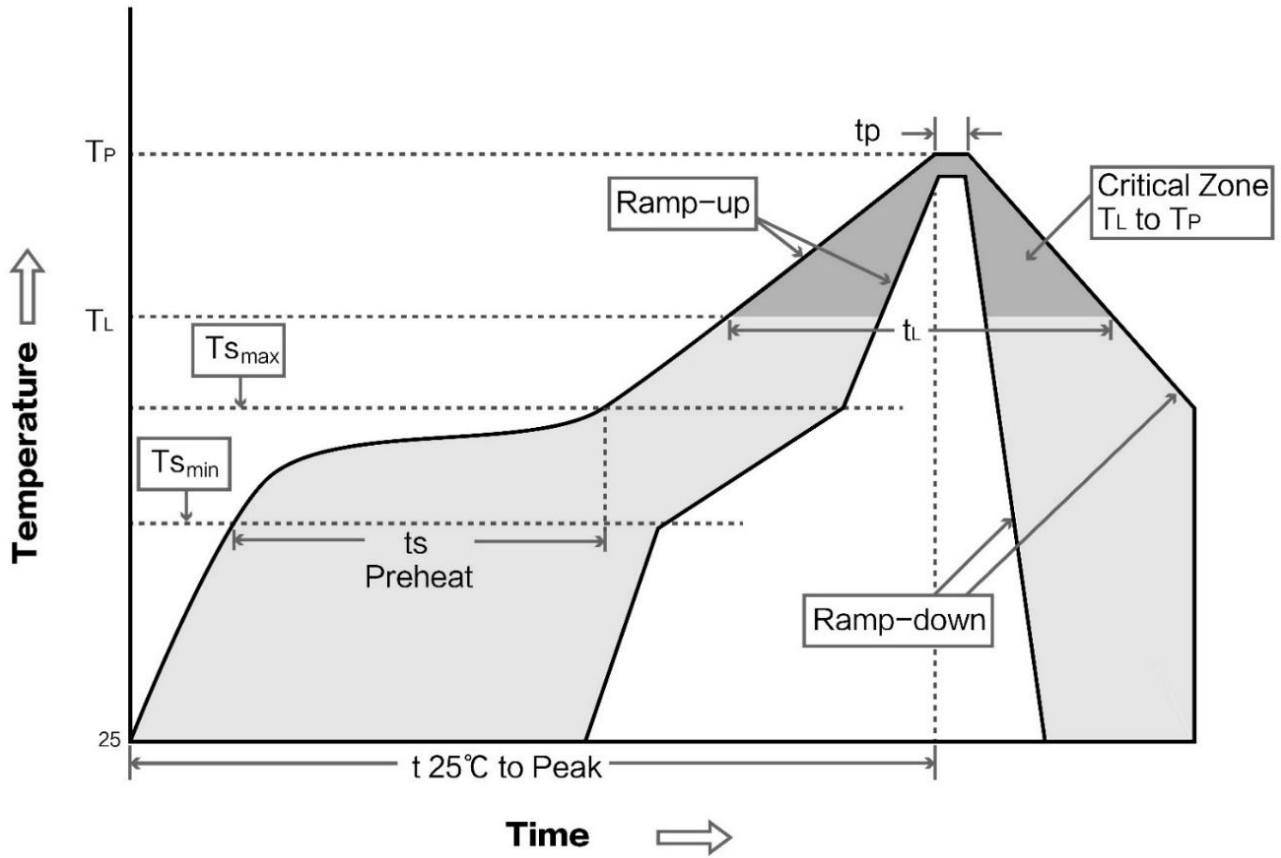

## 8.E19 Series

Model No.	IC	Frequency(Hz)	Tx power (dBm)	Test distance km	Package	Antenna	Model No.
<a href="#">E19-433M20S2</a>	SX1278	433M	20	5	SMD	15 * 15	Stamp hole
<a href="#">E19-915M30S</a>	SX1276	915M	30	10	SMD	25 * 40	Stamp hole /IPEX
<a href="#">E19-868M30S</a>	SX1276	868M	30	10	SMD	25 * 40	Stamp hole /IPEX
<a href="#">E19-868M20S</a>	SX1276	868M	20	5	SMD	17.6*25.2	Stamp hole
<a href="#">E19-433M30S</a>	SX1278	433M	30	10	SMD	25*37	Stamp hole
<a href="#">E19-915M20S</a>	SX1276	915M	20	5	SMD	17.6*25.2	Stamp hole
<a href="#">E19-433M20SC</a>	SX1278	433M	20	5	SMD	17.6*25.2	Stamp hole

## 9. Antenna guidance

### 9.1 Antenna recommendation

The antenna is an important role in the communication process. A good antenna can largely improve the communication system. Therefore, we recommend some antennas for wireless modules with excellent performance and reasonable price.

Model No.	Type	Frequency Hz	Interface	Gain dBi	Height	Cable	Function feature
<a href="#">TX915-XP-100</a>	Sucker	915M	SMA-J	3.5	25cm	100cm	Sucker antenna, High gain
<a href="#">TX915-JK-20</a>	Rubber	915M	SMA-J	3	210mm	-	Flexible & omnidirectiona
<a href="#">TX915-JK-11</a>	Rubber	915M	SMA-J	2.5	110mm	-	Flexible & omnidirectiona
<a href="#">TX915-JZ-5</a>	Rubber	915M	SMA-J	2	50mm	-	Flexible & omnidirectional

### 9.2 Antenna selection

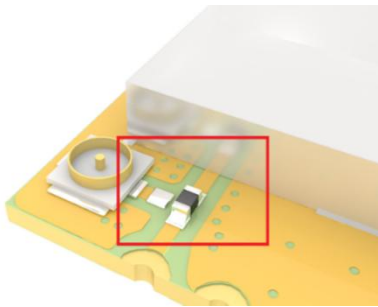

Stamp hole (default)

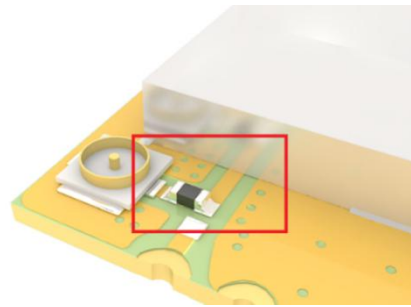

IPEX

## 10. Package for batch order

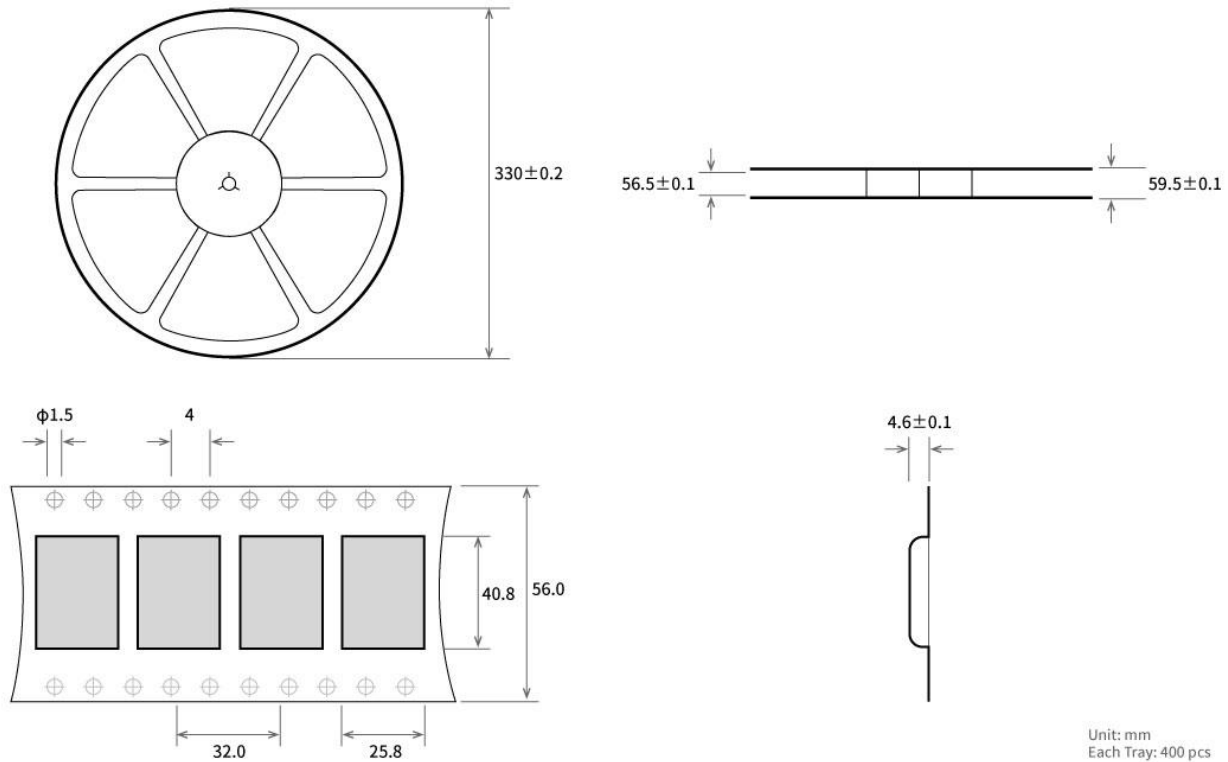

## Revision history

Version	Date	Description	Issued by
1.00	2017/10/16	Initial version	huaa
1.10	2018/5/23	Content updated	huaa
1.20	2018/9/21	Model No. split	Huaa

## About us

Website: [www.ebyte.com](http://www.ebyte.com)

Sales: [info@cdebyte.com](mailto:info@cdebyte.com)

Support: [support@cdebyte.com](mailto:support@cdebyte.com)

Tel: +86-28-61399028 Ext. 812

Fax: +86-28-64146160

Address: Innovation Center B333~D347, 4# XI-XIN road, High-tech district (west), Chengdu, Sichuan, China



**Chengdu Ebyte Electronic Technology Co.,Ltd.**