

DDM4006 Servo Motor

DDM4006, servo motor for nacelle PTZ, Robots, Industrial PTZ...

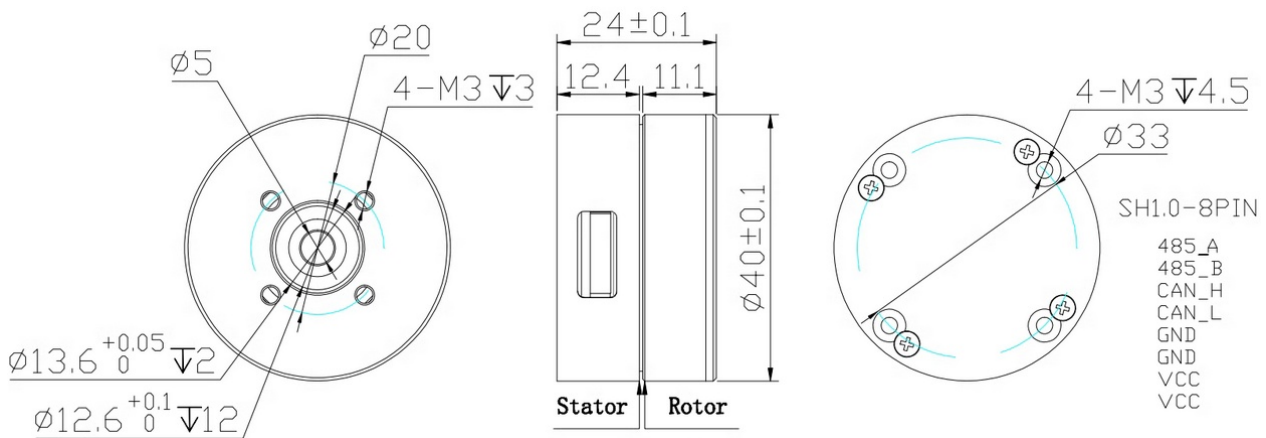

Dimension



Specification

Motor Data	Unit	Type:DDM4006
1 Nominal voltage	V	12
2 Voltage range	V	5-28
3 Nominal current	A	1.1
4 Nominal Power	W	13.2
4 Nominal torque	N.m	0.09
5 Nominal speed	rpm	467
6 Max speed	rpm	1412
7 Stall torque	N.m	0.15
8 Torque constant	Nm/A	0.08
9 Stall current	A	1.9
10 Speed constant	rpm/V	117
11 Torque constant	Nm/A	0.08
12 Number of pole pairs		11
13 Phase to phase resistance	Ω	3.17
14 Phase to phase inductance	mH	0.54
15 Communication	RS485/CAN	
16 Encoder type		Single-turn absolute
17 Resolution	bit	14
18 Weight	g	70
19 Working temperature	$^{\circ}\text{C}$	-20/80