

User's Guide

SP100 - 100 MHz hands-free oscilloscope probe

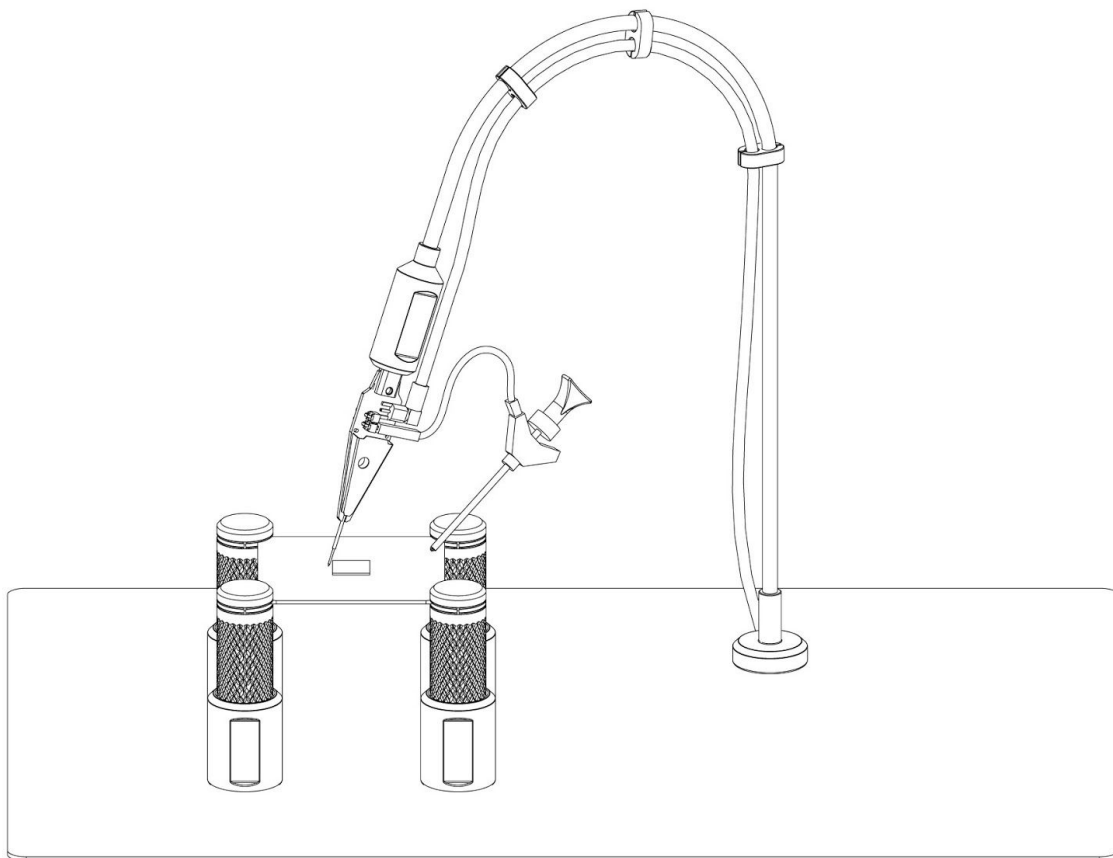

Introduction

This passive high-impedance oscilloscope probe is suitable for most oscilloscopes with a 1 MΩ input impedance.

Warranty

Sensepeek products are warranted for 12 months from the date of purchase. The warranty covers defects in material and workmanship. This warranty does not apply to components (parts and accessories) subject to natural and normal wear and tear. This warranty does not in any way limit the rights you have under mandatory law.

Disposal



Sensepeek offers our customers the opportunity to return products at the end of their functional lives to Sensepeek for recycling. Qualifying products are marked with the WEEE symbol shown above. Or ensure WEEE compliant collection and treatment yourself. Do not dispose of this product as unsorted municipal waste

Delivery cost of any authorized product returned to Sensepeek will be at the expense of the sender.

Safety

To prevent possible death, personal injury, electrical shock, fire or damage to the product, carefully read this safety information before use of the product. Follow all generally accepted safety practices and procedures for working with and near electricity. The product has been designed in accordance with the IEC 61010-031 standard and left the factory tested and in a safe condition.



Safety descriptions found throughout this user guide: A WARNING identifies conditions or practices that could result in death or injury. To prevent injury or death only qualified personnel should use this product, only as instructed and with only accessories supplied or

recommended. Protection provided by the product may be impaired if used in a manner not specified in this guide.



A CAUTION identifies conditions or practices that could result in damage to connected product or equipment.

Maximum input ranges

The full-scale measurement ranges are the maximum voltages that can be accurately measured by the probe for safe operation. The overvoltage ranges are the maximum voltages that will not damage the probe.



WARNING To prevent electric shock, do not connect the probe to voltages exceeding the levels specified in this user guide and do take all necessary safety precautions when working on equipment where hazardous live voltages may be present.



WARNING Do not connect to a mains voltage or a derived voltage that can carry the overvoltage transients that may be present. Note that the probe's maximum input voltage rating decreases as the frequency of the applied signal increases. This probe does not carry a measurement category rating.

Grounding



WARNING Do not ever connect the ground input to, or allow it to touch, any electrical potential other than ground. To prevent death or personal injury, always measure that there is no significant DC or AC voltage between the probe ground and the point to which you intend to connect it.



CAUTION Applying a voltage to the ground input is likely to cause permanent damage to the probe or other connected equipment.

Environment



WARNING To prevent death or injury, do not use near explosive vapor or gas.



CAUTION To prevent damage to the probe, always operate and store your probe according to the levels specified in this guide.

Care of the product

The probe contains no user-serviceable parts.



WARNING To prevent death or injury, do not try to open any part of the assembly, do not use the product if it appears to be damaged in any way, and stop use immediately if it behaves abnormally.



CAUTION Always handle with care to avoid injury from the sharp tip. Ensure that the probe is completely dry before use. Do not allow liquids to enter the probe. Take care to avoid mechanical stress or tight bends on the arm and cable connecting the probe head to the oscilloscope. Mishandling will degrade performance and measurement accuracy and is not covered by the warranty. Avoid all kind of mechanical shock to the probe assembly.

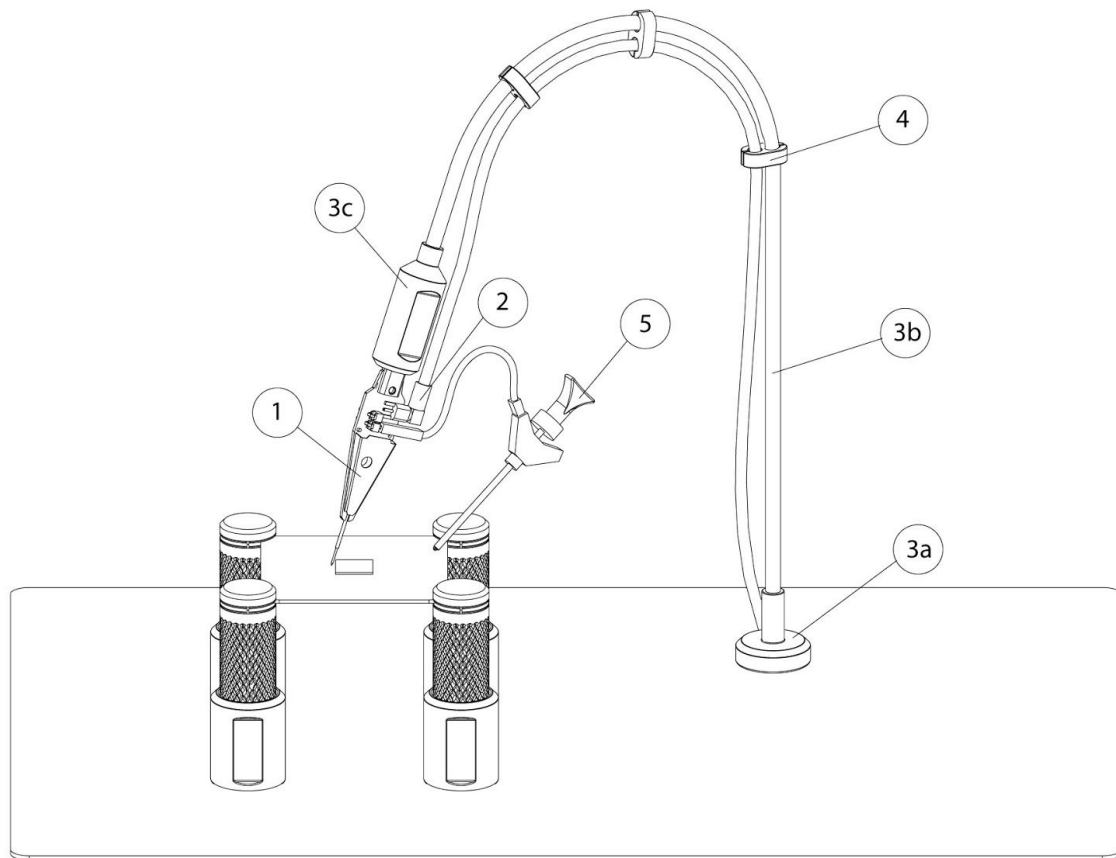

Overview

1. Probe head
2. Probe cable (detachable)
3. Probe arm
 - a. Probe base (with magnet)
 - b. Flexible arm
 - c. Probe arm grip
4. Color coded cable holder
5. Test hook (ground) with wire

Getting started

1. Attach probe head to the probe arm with the M4 thread
2. Connect the probe cable
3. Snap on the color coded cable holders on the flexible arm and the probe cable to hold and identify your oscilloscope channel
4. Connect the test hook to the ground pin header
5. Connect the probe cable BNC connector (not shown in picture) to your instrument (oscilloscope)

6. Calibrate your probe according to the Frequency compensation chapter.

Frequency compensation

Check the compensation of the probe before taking any measurements and always adjust it to match the oscilloscope input channel. Connect the probe head needle to a 1 kHz square wave of ~2 V pk-pk. Most oscilloscopes have a signal generator output with a test signal that can be used. Adjust the trimmer at the BNC until you see a flat-top square wave on the oscilloscope display* by rotating the adjustment tool clockwise.

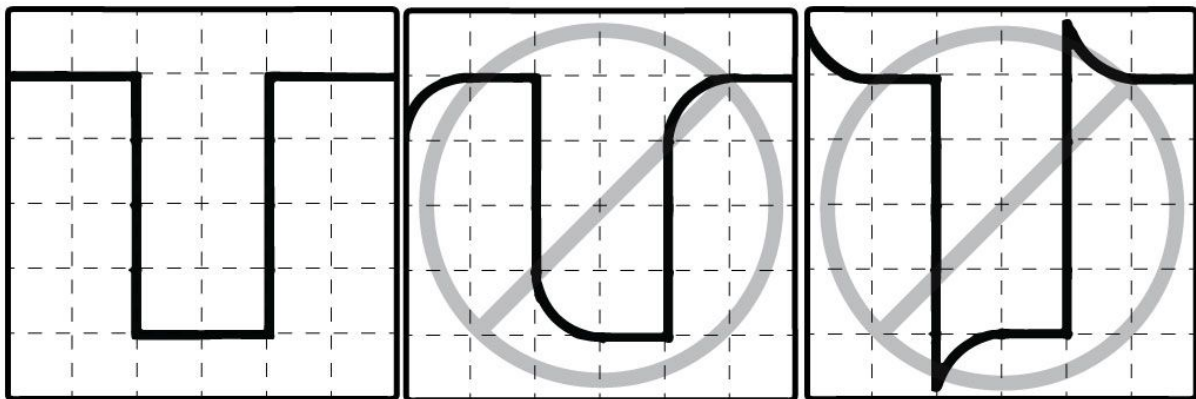

*The probe can not meet the full specification if under or over compensated or incorrectly adjusted. The better compensated, the flatter the frequency response and higher bandwidth you will obtain.

Ground loop

Try to use a grounding point as close as possible to the component being measured. A small ground loop injects less noise. Do not increase the length of the ground cable. Making it shorter will only affect the measurement in a positive way with higher bandwidth and less noise.

Operating instructions

Position the probe - Place the probe foot on the base plate and the magnet will keep it in place.

Reposition the probe - Slide the probe foot on the base plate

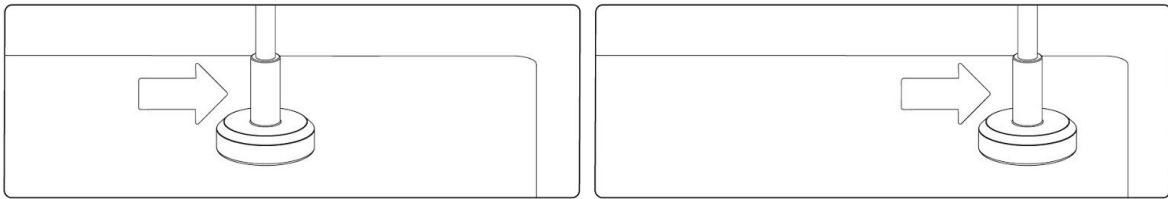

Detaching the probe - Tilt the probe foot gently and remove the probe arm. Avoid pulling on the flexible arm!

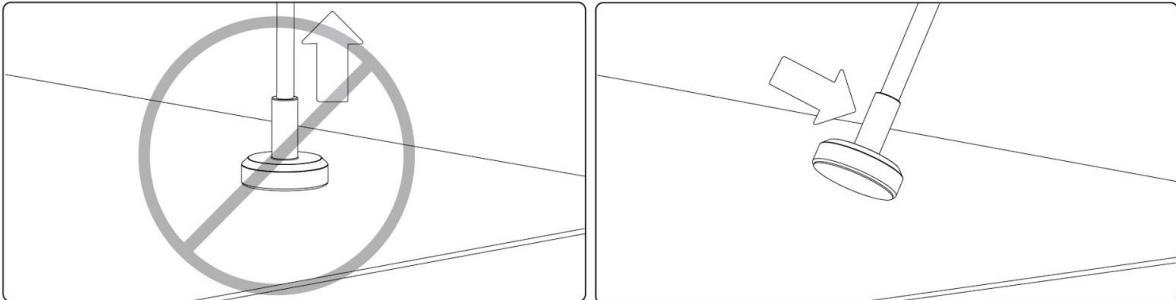

Measuring with the probe

1. Lift the probe in the probe grip
2. Compress the needle to the measuring target
3. Release the probe grip gently

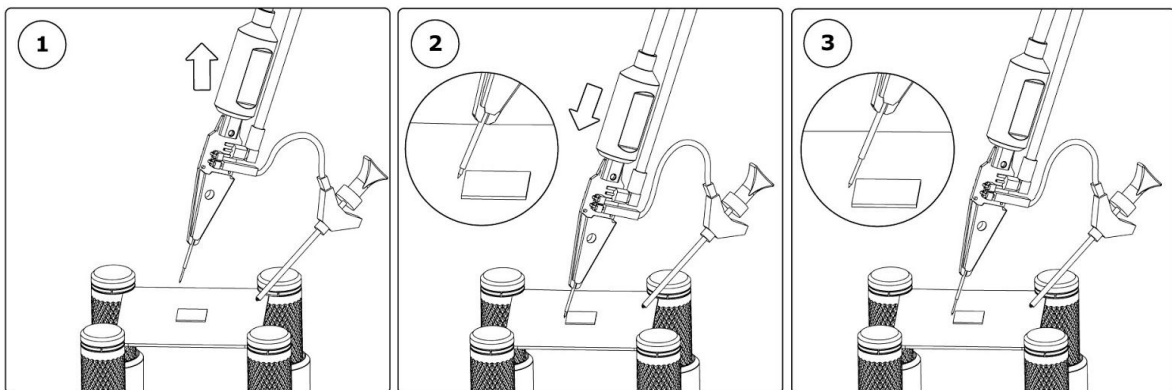

Probe needle replacement

1. Notice the replaceable needle tip. Please be aware of the sharp needle tip!
2. Pull out the replaceable needle tip by hand or use pliers.
3. Pick up the new needle tip and insert in the sleeve with pliers.

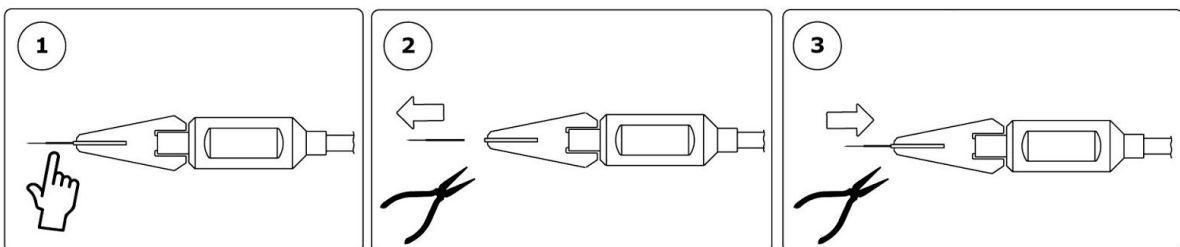

Specifications

Probe Characteristics	
Model	SP100
Bandwidth > = f3dB (MHz)*	100
Rise time (ns), calculated	3.2
Attenuation Ratio	10
Input Resistance (MΩ), ± 2%	10
Input Capacitance (pF)	14 - 18
Full-scale measurement range (for safe operation) Maximum Input: 10:1 Input Voltage, Fulfill the signal voltage limits of EN 61010-031:2015	Voltage: +/-60 V DC, 30 V AC RMS, +/-42.4 V pk max.
Overvoltage protection (voltage that will not damage)	200 V DC + peak AC
Compensation Range (pF)	15 - 45
Operating Environment, Max. altitude 2 km	-20 to +60 °C, 0 to 80% RH
Storage Environment, Max. altitude 15 km	-20 to +60 °C, 0 to 80% RH
Probe tip diameter (mm)	0.5
Probe tip angle (Degrees)	30
Pollution Degree	2
RoHS and REACH compliant	Yes

*The probes can continue to measure above the rated bandwidth but with decreased signal, the probe will reach the f3dB limit above the rated bandwidth. The probe has a flatness of ±0.5dB over the first 1/3 of the bandwidth and less than the ±3dB over the specified bandwidth.