

# **Product Manual of TFmini (I<sup>2</sup>C)**



**Mini LiDAR Module**

[www.benewake.com](http://www.benewake.com)  
Benewake (Beijing) Co., Ltd.

## Specified Product

Product model: TFmini-I<sup>2</sup>C

Product name: Mini LiDAR Module

## Manufacturer

Company name: Benewake (Beijing) Co. Ltd.

Address: No.28, Xinxu Road, Haidian District, Beijing, PRC

## Copyright

The Copyright of this document is protected. All the rights involved herein belong to Benewake (Beijing) Co. Ltd. Any copy activity of this document, no matter in whole or in part, should be in conformity of the Copyright Law. The actives of Modification, omission or translation of this document are not allowed unless a written permission from Benewake (Beijing) Co. Ltd.

All rights reserved © Benewake (Beijing) Co. Ltd.

## Product Certification



## Foreword

Dear users,

Thanks for choosing Benewake products, and it's our pleasure to help you to solve any technical question.

In the purpose of offering a better operation experience to you, we hereby write this manual for an easier and simpler operation of our product, hoping to better solve the common problems you maybe meet.

This operation manual covers the product operation introduction and common problem solutions, but it is really hard to covers all the problems you maybe meet. So if you have any further questions or problems, please feel free to consult our technical support service ([support@benewake.com](mailto:support@benewake.com)). We will do our best to solve any problem related to the product. If you have any other good advice or suggestion, welcome to visit our official website and offer us your feedback there (<http://benewake.com/en/mfeedback.html>), and we are looking forwards to your participation.

The various application development routines for this product can be found at <https://github.com/TFmini>. If the development routines on this page do not meet your needs, you can contact us at [support@benewake.com](mailto:support@benewake.com), we will improve the development routine as soon as possible.

We are Benewake who dedicated to making the best “Robotic Eyes” worldwide!

# Table of Contents

<b>1</b>	<b>Attentions</b> .....	<b>6</b>
1.1	About this Document .....	6
1.2	Usage of Product .....	6
1.3	Conditions with Potential Product Failure.....	6
<b>2</b>	<b>Functions and Key Parameters</b> .....	<b>6</b>
2.1	Product Functions .....	6
2.2	Principle of Distance Measurement.....	7
2.3	Key Characteristic Parameters .....	7
2.4	Distance Measurement Characteristics .....	7
<b>3</b>	<b>Appearance and Structure</b> .....	<b>9</b>
3.1	Product Appearance.....	9
3.2	Production Structure .....	10
<b>4</b>	<b>Electrical Characteristics</b> .....	<b>10</b>
<b>5</b>	<b>Line Sequence and Data Communication Protocol</b> .....	<b>11</b>
5.1	Description about Line Sequence and Connection .....	11
5.2	Data Communication Protocol .....	11
5.3	Time Sequence of Reading Data from TFmini-I2C .....	12
5.4	Descriptions of Output Data.....	13
<b>6</b>	<b>Descriptions on Configurable parameters</b> .....	<b>13</b>
6.1	Function Overview .....	13
6.2	Time Sequence of TFmini-I2C Parameters Configuration .....	14
6.3	Descriptions of General Parameter Configuration .....	15
6.4	Descriptions of Special Parameter Configuration .....	16
6.5	Time Sequence of Resetting .....	17

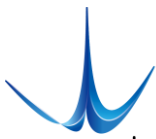

7	<b>Faults: Causes and Troubleshooting</b> .....	17
8	<b>QA</b> .....	18



## 1 Attentions

### 1.1 About this Document

- This manual provides all the essential information during the usage of this product.
- Please carefully read this manual and make sure that you fully understand everything herein.

### 1.2 Usage of Product

- The maintenance work of this product is limited to the professional technician, and the product can only work with the factory spare part for ensuring the performance and safety thereof.
- This product itself has no polarity and over-voltage protection. Please properly connect and supply power as per the manuals herein.
- Operating temperature of this product is between 0°C and 60°C. Do not use it beyond this temperature range to avoid risk.
- Storage temperature of this product is between -20°C and 75°C. Do not store it beyond this temperature range to avoid risk.
- For ensuring the product performance, do not open the product shell or do any assembly or maintenance that not listed in this manual.

### 1.3 Conditions with Potential Product Failure

- The product will be subject to risk of failure if the detecting object has high reflectivity, such as the mirror or the smooth floor tile.
- The product will be subject to risk of failure if there is any transparent object between it and the detecting object, such as glass or water.
- The product will be subject to risk of failure if its transmitting or receiving lens is covered by the dust. Please keep the lens clean.
- Please do not directly touch circuit board of the product by hand as it is exposed. Please wear antistatic wrist strap or glove if necessary; Otherwise, the product will be subject to risk of failure, which is shown by failure of normal operation, and even it will be broken.

## 2 Functions and Key Parameters

### 2.1 Product Functions

TFmini-I<sup>2</sup>C is a mini LiDAR module. It is mainly capable of the function of real-time and contactless distance measurement and is featured by accurate, stable and high-speed distance measurement.



## 2.2 Principle of Distance Measurement

TFmini-I<sup>2</sup>C is based on TOF, namely, Time of Flight principle. To be specific, the product transmits modulation wave of near infrared ray on a periodic basis, which wave will reflect after contacting object. The product obtains time of flight by measuring round-trip phase difference and then calculates relative range between the product and the detection object, as shown in Figure 1.

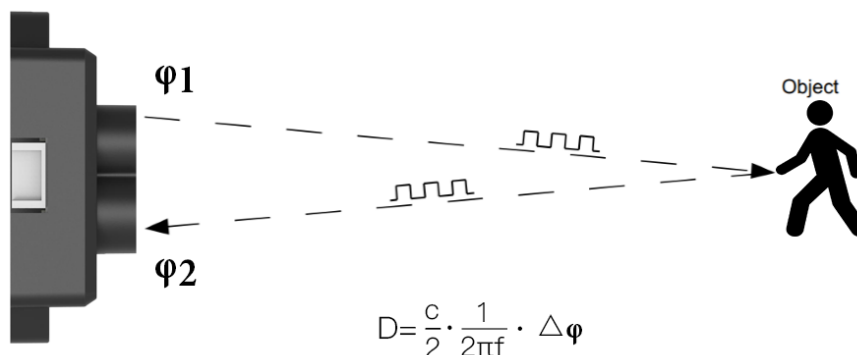

Figure 1 Schematics of TOF Principle

## 2.3 Key Characteristic Parameters

Table 1 Key Characteristic Parameters of TFmini

Description	Parameter value
Operating Range	0.3m~12m <sup>①</sup>
Measurement accuracy	±4cm@ (0.3m-6m) <sup>②</sup>
	±1%@ (6m-12m)
Default unit of distance	cm
Range resolution	1cm
Receiving half angle	1.15°
Transmitting half angle	1.5°
Frequency	100Hz

① Operating Range reachable under indoor standard white board condition (with reflectivity of 90%);

② A few points may be subject to an error of ±6cm due to switchover of distance measurement position within 0.3-2m.

## 2.4 Distance Measurement Characteristics

With optimization of light path and algorithm, TFmini-I<sup>2</sup>C has minimized influence from external environment on distance measurement performance. Despite that, the range of distance measurement may still be affected by the environment illumination intensity and the reflectivity of detection object. As shown in Figure 2:

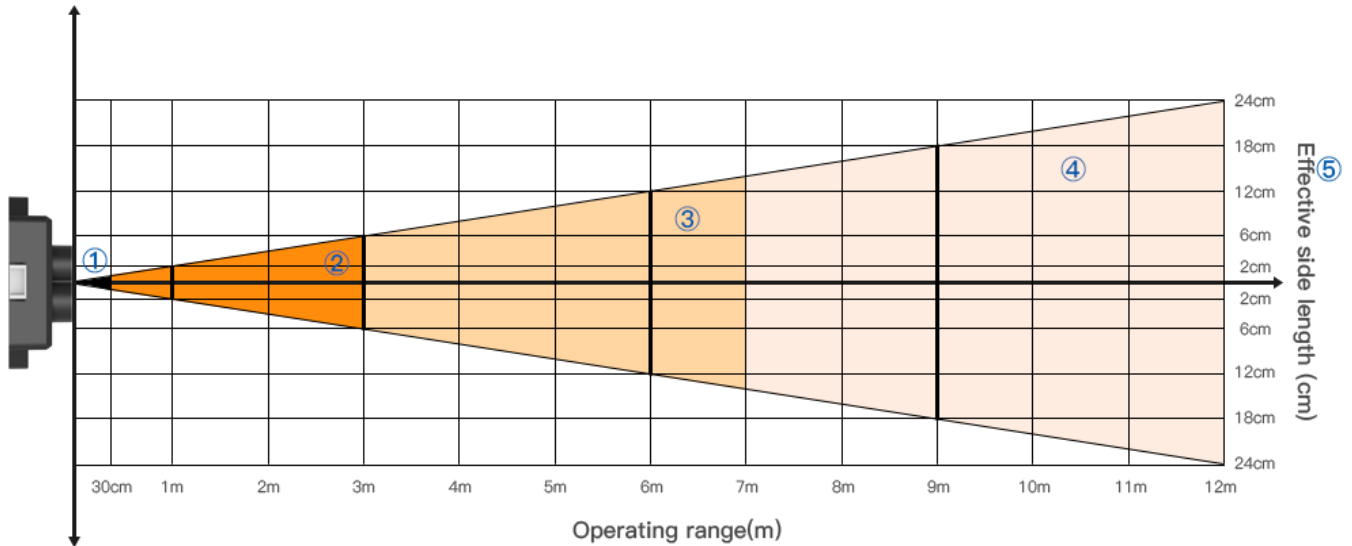

Figure 2 Schematics of Range of distance measurement and Effectiveness of the Product

- ①: Represents the detection blind area of TFmini-I<sup>2</sup>C, 0-30cm, within which the data is unreliable.
- ②: Represents the operating range of TFmini-I<sup>2</sup>C under extreme condition, which generally is 0.3-3m. Extreme condition refers to the outdoor glare (of which illumination intensity is around 100klux outdoors at noon in summer) and detection of black target (with reflectivity of 10%).
- ③: Represents the operating range of TFmini-I<sup>2</sup>C for white target under normal sunshine condition (with illumination intensity of around 70klux), which covers the range of ② and is 0.3-7m.
- ④: Represents the operating range of TFmini-I<sup>2</sup>C at the indoor environment or considerably weak ambient light environment, which is 0.3-12m.
- ⑤: Represents the Minimum side length of effective detection for TFmini-I<sup>2</sup>C at the different distances. The data will not be stable and reliable unless “the side length of detection object” is equal to or more than the Minimum side length. The Minimum side length of effective detection depends on the FOV of TFmini-I<sup>2</sup>C (the term of FOV generally refers to the smaller value between the receiving angle and the transmitting angle), which is calculated as follows:

$$d = 2 \cdot D \cdot \tan\beta$$

In the above formula, d is the Minimum side length of effective detection; D is detecting range;  $\beta$  is the half of the value of the receiving angle of TFmini-I<sup>2</sup>C, 1.15°. Correspondence between the Minimum side length of effective detection and detecting range in general is given in Table 2.

Table 2 the Minimum side length of effective detection corresponding to Detecting Range

Detecting range	1m	2m	3m	4m	5m	6m	7m	8m	9m	10m	11m	12m
Minimum side length	4cm	8cm	12cm	16cm	20cm	24cm	28cm	32cm	36cm	40cm	44cm	48cm





If the detection object cannot reach the Minimum side length of effective detection, as shown in Figure 3, the output (Dist) from TFmini-I<sup>2</sup>C will be a value between the actual distance values of the two objects. For a high accuracy requirements in practice, the above situation should be noticed to avoid the measurement error .

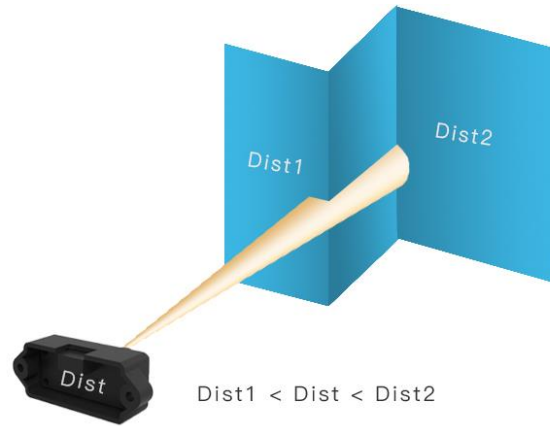

Figure 3 Distance Measurement in the case of Two Objects in Different Distances

### 3 Appearance and Structure

#### 3.1 Product Appearance

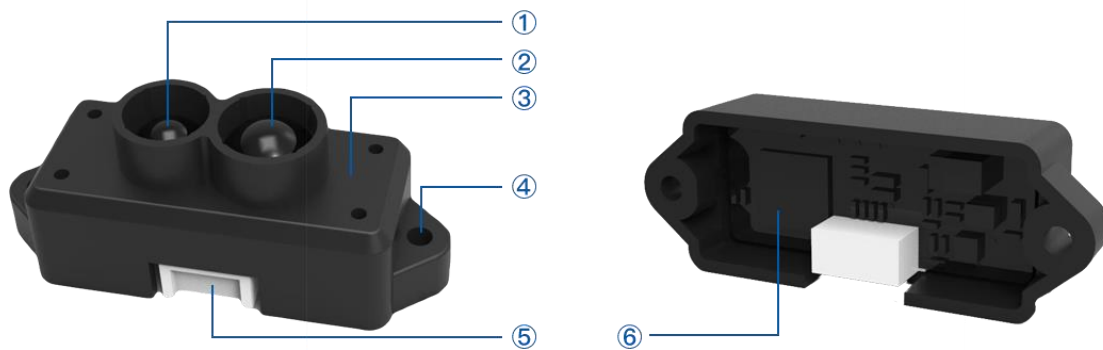

Figure 4 TFmini-I<sup>2</sup>C Product Appearance

- ① Transmitting lens
- ② Receiving lens
- ③ Enclosure, made of ABS+PC
- ④ Mounting hole is 2.35mm through hole. ST2.9 self-tapping screw is recommended for mounting and fixing.
- ⑤ Connecting terminal, GH1.25-4p SMT type; And along with the product there is a10cm long connecting wire.
- ⑥ Circuit board, without covering enclosure at the rear of product.



### 3.2 Production Structure

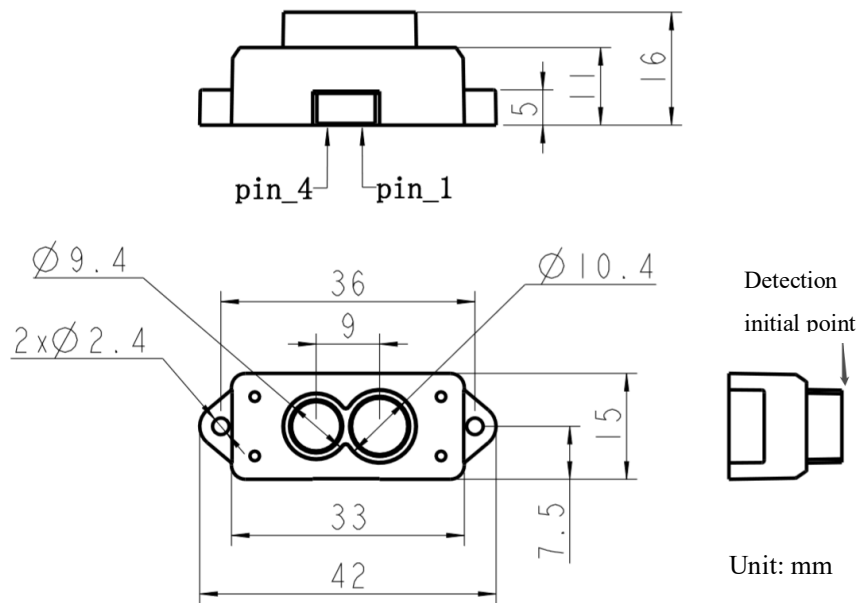

Figure 5 Constructional Drawing of TFmini-I<sup>2</sup>C

## 4 Electrical Characteristics

Table 3 Major Electrical Parameters of TFmini-I<sup>2</sup>C

Description	Parameter value
Power supply voltage	5V
Average current	≤140mA
Peak current	800mA
Average power	≤0.7W
Communication level	3.3V

This product has no overvoltage nor polarity protection, so please make sure that connection and power supply are normal. The fluctuation of the power supply voltage in a range of  $\pm 0.1V$  is allowable.

Average current varies along with the operating modes of the product in two patterns, more specifically, its current is around 70mA under short distance mode and it is around 120mA under long distance mode. Please make sure that the power supply current meets the peak current of 800mA. In case of insufficient power supply current, the product maybe can't work normally.



## 5 Line Sequence and Data Communication Protocol

### 5.1 Description about Line Sequence and Connection

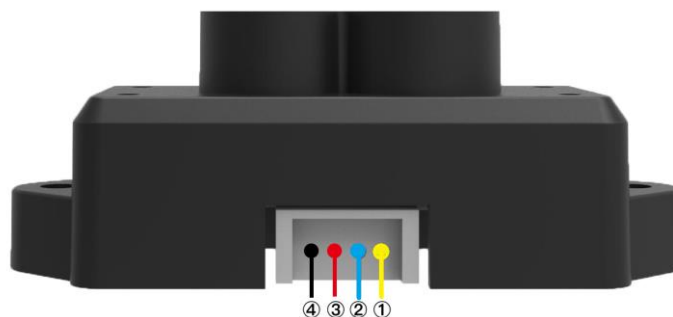

Figure 6 Line Sequence

Table 4: The Function and Connection Description of each pin

No.	I <sup>2</sup> C line sequence	Corresponding connection item
①	SCL	SCL
②	SDA	SDA
③	+5V	Positive pole of power supply
④	GND	Power Ground

Type of connecting terminal: GH1.25-4P. The product includes a 10cm long connecting wire, the other end of which is a conventional 1.25-4p terminal (Molex510210400).

### 5.2 Data Communication Protocol

TFmini-I<sup>2</sup>C adopts I<sup>2</sup>C data communication protocol, as given in Table 5.

Table 5 Data Communication Protocol of TFmini-I<sup>2</sup>C

Communication interface	I <sup>2</sup> C
Maximum transfer speed	400kbit/s
Master-slave mode	Slave mode
Default address	0x07
Address range	0x07-0x78



### 5.3 Time Sequence of Reading Data from TFmini-I2C

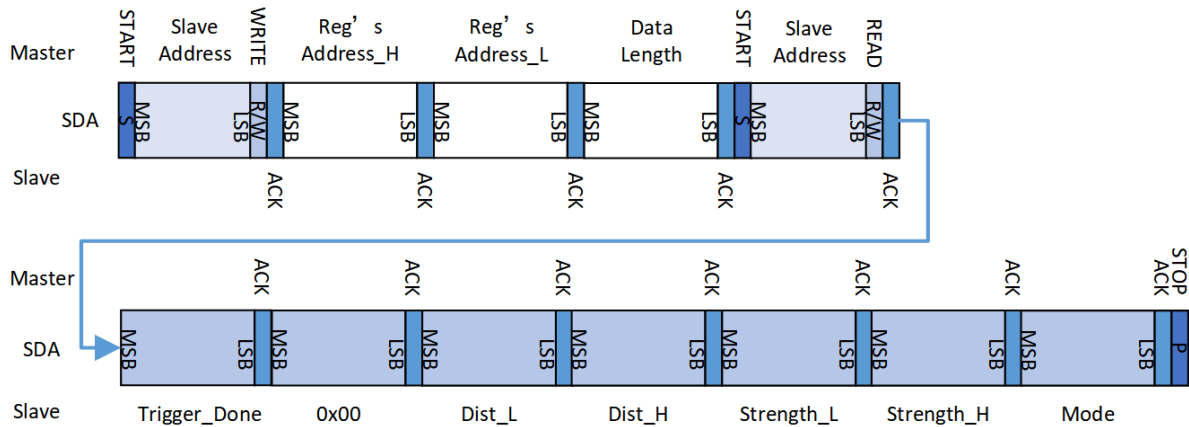

Figure 7 Time Sequence of Reading Data from TFmini-I2C

Explanations are in Table 6.

Table 6 Data Format and Code Explanation

Data Format and Code Explanation	
START	Start condition
STOP	Stop condition
Slave Address	Slave address, which is 0x07 by default and is configurable.
R/ $\bar{W}$	R/W flag bit; R/ $\bar{W}$ =1 indicates READ; R/ $\bar{W}$ =0 indicates WRITE
ACK	Acknowledge ,Master/slave response
Reg's Address_H	Higher 8 bits of the register address. When reading range information, Reg's Address_H = 0x01
Reg's Address_L	Lower 8 bits of the register address. When reading range information, Reg's Address_L = 0x02
Data Length	Read the number of bytes of range information. When reading range information, Data Length = 0x07
Trigger_Done	Measurement completion flag. Trigger_Done = 0x01 indicates ranging results of the current frame Trigger_Done = 0x00 indicates ranging results of the previous frame
Dist_L	Lower 8 bits of distance value
Dist_H	Higher 8 bits of distance value
Strength_L	Lower 8 bits of signal strength
Strength_H	Higher 8 bits of signal strength
Mode	Ranging gear information, which goes into automatic switch mode by default Range of values: 00 (short distance), 03 (middle distance), and 07 (long distance)



## 5.4 Descriptions of Output Data

**Dist:** Represents the output of the distance value detected by TFmini-I<sup>2</sup>C. The range of values is 0~1200 (unit of cm). During actual use, when signal Strength<20 (configurable), the Dist value is not credible, Dist=0xFFFF; when Strength $\geq$  20 and the actual distance is  $\geq$  1200cm, Dist=1200cm (configurable). (If the unit is mm, the range becomes 0~12000)

**Strength:** Represents the strength of return signal received by TFmini-I<sup>2</sup>C. The range of values is 0~3000. Under the same ranging gear, signal strength decreases with distance from the object and decreases with the reduction of object reflectivity. Under general conditions, when the value of Strength lies between 20 and 2000, the Dist value is credible. If the user environment is unitary and is free from external interference, “the lowest point of signal strength threshold value” can be adjusted to be less than 20, so as to utilize more valid data. The minimum and maximum effective threshold values of strength can be set by command.

**Mode:** Represents the ranging gear of TFmini-I<sup>2</sup>C. There are a total of three gears, namely 0x00, 0x03 and 0x07, where 0x00 represents short distance (0-2m) operating gear, 0x03 represents middle distance (0.5-5m) operating gear, and 0x07 presents long distance (1-12m) operating gear. The default operating mode is automatic switch mode, in which the module can automatically switch to the appropriate gear mode according to actual situation. Automatic switch mode or fixed mode can be set by command.

**Trigger\_Done:** During the ranging process of the module in each frame, there is a certain duration from emission of light to receiving of light and then to the calculation of distance. When the command to query distance is sent before measurement in this frame ends, the module will return the measured data in the previous frame, Trigger\_Done=0x00.

## 6 Descriptions on Configurable parameters

### 6.1 Function Overview

The function of configurable parameters is hereby enabled for more flexible settlement of your problems by TFmini-I<sup>2</sup>C. User may modify original parameters by sending relevant instructions, such as output data format and output cycle, etc. Upon successful configuration, the configured parameters will be saved in Flash without the need of reconfiguration for reboot or power off(excluding slave address).

Please modify product configuration depending upon your actual demands. Do not frequently try irrelevant instructions so as to prevent incorrect sending of instruction which many cause unnecessary loss. Please make sure to make the configuration as per the instructions listed herein. Do not send unstated instruction.



## 6.2 Time Sequence of TFmini-I2C Parameters Configuration

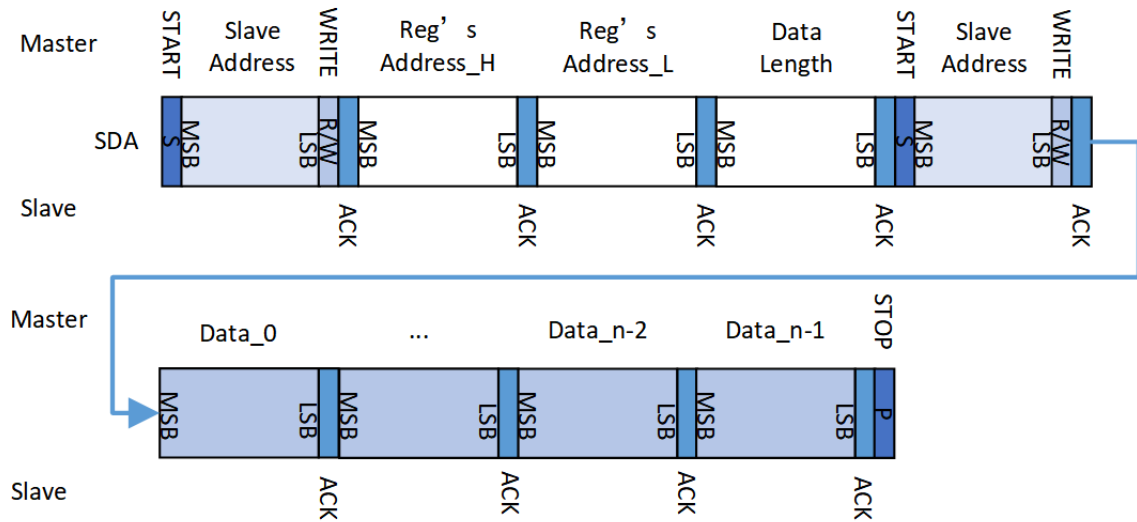

Figure 8 Time Sequence of TFmini-I2C Parameters Configuration

Data codes are detailed in Table 7.

Table 7 Data Format and Code Explanation

Data Format and Code Explanation			
START	Start condition		
STOP	Stop condition		
Slave Address	Slave address, which is 0x07 by default and is configurable.		
R/ $\bar{W}$	R/W flag bit; R/ $\bar{W}$ =1 indicates READ; R/ $\bar{W}$ =0 indicates WRITE		
ACK	Acknowledge , Master/slave response		
Reg's Address_H	Higher 8 bits of the register address		
Reg's Address_L	Lower 8 bits of the register address		
Data_Length	Number of bytes of read/write data. Total number of bytes of Data_0 ~ Data_n-1		
Data n	Configuration value of the register. The double-byte parameter has the lower 8 bits in front and the upper 8 bits at the back.		
	Mapping relation between parameter and register address:		
	Reg's Address+0	Reg's Address+1	Reg's Address+n-1
Data_0	Data_1	Data_n-1	



### 6.3 Descriptions of General Parameter Configuration

Table 8 Descriptions of General Parameter Configuration

S.N.	Configurable items	Register address	Value	Description	Default
①	Ranging gear mode	0x0050	0x00	Short distance mode, applicable for about 0.3-2m	/
			0x03	Middle distance mode, applicable for about 0.5-5m	
			0x07	Long distance mode, applicable for about 1-12m	
	Detection pattern	0x0051	0x00	Automatic detection pattern	0x00
		0x01	Fix detection pattern		
②	Setting of range limit	0x0055	0x00	Range limit disabled	0x01
				0x01	
	Range output limit threshold	0x0056~0x0057	0x0000~0xFFFF	Unit: mm	12000 (DEC)
③	lower limit of signal strength threshold	0x0058~0x0059	0x0000~0xFFFF	When Strength is lower than that value, the distance output is 0xFFFF, and is not credible to be used as flag.	20 (DEC)
④	upper limit of signal strength threshold	0x005A~0x005B	0x0000~0xFFFF	/	0xFFFF
	Output value of signal strength threshold at the highest point	0x005C~0x005D	0x0000~0xFFFF	Unit: mm	0
⑤	Unit of distance	0x0066	0x00	0x00 indicates millimeter (mm)	0x01
			0x01	0x01 indicates centimeter (cm)	

#### Explanation:

① TFmini-I<sup>2</sup>C is built in with two distance modes which are automatically switchable by default. As there is a larger error during the automatic switchover of the two modes, the user may choose fixed detection pattern if there are high accuracy requirement within the limited measurement range. During the usage, please input the command for the fixed detection pattern at first and then send configuration instruction of the distance mode. The long/short distance mode configuration will become invalid once the TFmini-I<sup>2</sup>C starts the automatic switchover of distance modes.

② The range output limit is 12 meters and it is enabled by default. When the limit is disabled, the measurement data in the range of 0-15m can be output. However, the data above 12m is fitting data with significant error. So the range limit are modifiable by the user depending upon the demands. Upon the modification, the set threshold will be output if the measurement data more than such threshold.



③ The setting of minimum signal strength threshold will be valid only if ③ is enabled, and it is 20 by default, which means that the distance value will output FF if the Strength is less than 20. The user may increase such threshold in order to improve reliability of the distance measurement value. But note that the maximum threshold should be no more than 80; otherwise the LiDAR may not operate normally. Correspondingly the threshold may be decreased in order to improve the measurement range of TFmini-I<sup>2</sup>C.

④ The setting of the maximum signal strength threshold will be valid only if ⑤ is enabled. Such function is used when the user wants to set a fixed value for the near distance object detection. For example, if the user has to use the TFmini-I<sup>2</sup>C within its blind zone, this command can be input and then the output value of the blind zone will be set to a fixed value in order to maintain a stable data.

⑤ The unit of distance output generally is cm by default and can be modified into mm. With the unit modified into mm, the distance change at level of mm is available, allowing the product to be applicable for the scenario with a single detection object and high accuracy requirement.

#### 6.4 Descriptions of Special Parameter Configuration

The procedures of special parameter configuration are same as the general parameter configuration. Besides, the setting of slave address and trigger source is not valid until power-on or reset.

Table 9 Special Parameter Configuration and Description

S.N.	Configurable items	Register address	Value	Description	Default
⑥	Slave address	0x0026	0x07~0x78	/	0x07
⑦	Trigger mode	0x0027	0x00	Internal timer trigger, 100Hz by default	0x00
			0x01	External command trigger	
	External command trigger register	0x0100	0x01	Command for one single measurement	/
⑧	Reset	0x0070	0x02	All settings are reset to the default (excluding slave address and trigger mode)	/

#### Explanation:

⑥ Modification of slave address is not valid until power-on or reset.

⑦ There are two trigger modes for the measurement of TFmini-I<sup>2</sup>C. The default one is the internal timer trigger by the timer with one measurement per 10ms. The user may modify this mode into the external command trigger mode which allows the TFmini-I<sup>2</sup>C to start the distance measurement by an external trigger instruction. Please note that the trigger frequency of TFmini-I<sup>2</sup>C should in no way be more than 100Hz as the maximum.

⑧ Reset of default configuration. By sending such instruction, all adjustable configurations will be reset back to the default configurations (excluding slave address and trigger mode). Please use it with caution.





## 6.5 Time Sequence of Resetting

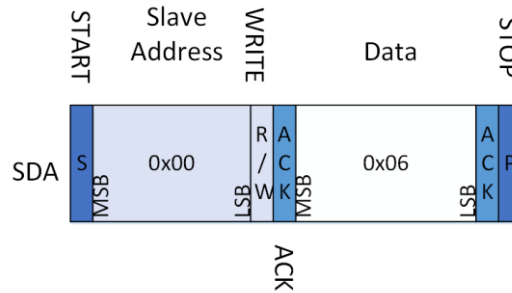

Figure 9 Time Sequence of Resetting TFmini

Table 1 Data Format and Code Explanation

Data Format and Code Explanation	
START	Start condition
STOP	Stop condition
Slave Address	Slave address, which is 0x07 by default and is configurable.
R/ $\bar{W}$	R/W flag bit; R/ $\bar{W}$ =1 indicates READ; R/ $\bar{W}$ =0 indicates WRITE
ACK	Acknowledge ,Master/slave response
Data	Value is 0x06

## 7 Faults: Causes and Troubleshooting

**(1) Distance value occasionally will abruptly change into a fixed value beyond the range during normal operation.**

**Cause:** The different test environments (reflectivity of detected object, disturbance of ambient light, etc.) will affect the signal strength of TFmini-I<sup>2</sup>C. For a reliable and stable measurement data, the algorithm elimination is internally used for TFmini-I<sup>2</sup>C. In case of the insufficient signal strength, TFmini-I<sup>2</sup>C will output 0xFF FF, as a special symbol under the default condition. This value is not measurement data of TFmini-I<sup>2</sup>C, which is only used to prompt the user that such data is unreliable.

**Troubleshooting:** You could use such value as the trigger signal of some unreliable data, and it will ensure that your system can use other reliable data for further assessment and decision-making if there are some unreliable data.

**(2) Significant error between the output distant value of LiDAR and actual distance**

**Cause ①:** Incorrect interpretation of the data communication protocol of TFmini-I<sup>2</sup>C.

**Troubleshooting:** check data communication interpretation means. In case of such error, please check the data format to adjust interpretation means.



**Cause ②:** Due to the physical principles of TFmini-I<sup>2</sup>C, the above phenomenon is likely to occur if the detection object is the material with high reflectivity (such as mirror, smooth floor tile, etc.) or transparent substance (such as glass and water, etc.)

**Troubleshooting:** Please avoid use of this product under such circumstance in practice.

**Cause ③:** Lens of the product are covered by the foreign matter.

**Troubleshooting:** please use dry dust-free cloth to gently remove the foreign matter

### (3) TFmini-I<sup>2</sup>C fails to output data

**Cause:** The product will be strictly inspected before leaving our factory, ensuring that all the shipped products can work normally. However, some abnormal working matters maybe still occur because of incidents during the transportation or use.

**Troubleshooting:** Check whether the power supply is normal; check whether the voltage is within rated voltage range. If power supply is normal, there will be a red light inside the transmitting lens of TFmini-I<sup>2</sup>C.

Check TFmini-I<sup>2</sup>C with correct connection sequence and reliable connection.

Check whether the data interpretation is correct. Please carry out the interpretation as per the data format specified herein.

If the problem persists, please contact our technical support.

## 8 QA

Q1: Is TFmini-I<sup>2</sup>C available with 3.3V or other power supply voltage?

A1: Sorry, it is not available for the time being. The Standard power supply of TFmini-I<sup>2</sup>C is 5V. If you have any further requirement, please contact our sales person to consult a customization design matter.

Q2: TFmini-I<sup>2</sup>C will heat up after operating for a while. Is it broken?

A2: This is the normal operating condition of the product. The temperature of the chip and circuit board will slightly up after a continuous operation, which is a normal case.