

Input Voltage Source Selection

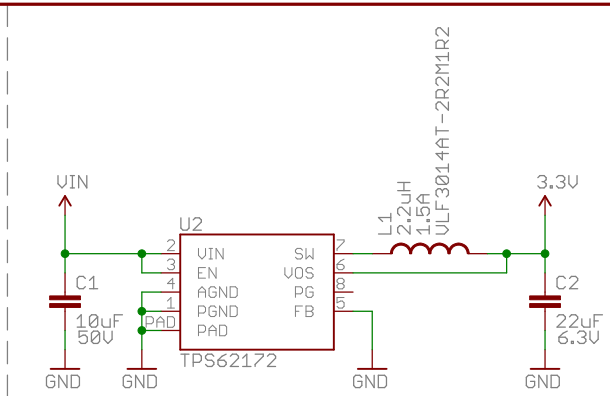

DC/DC Converter

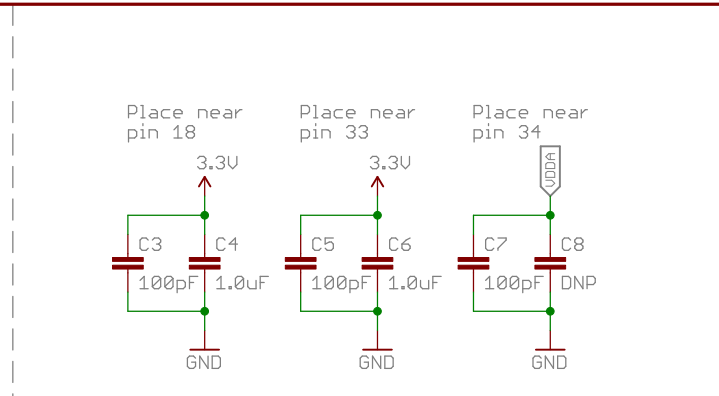

Decoupling Capacitors

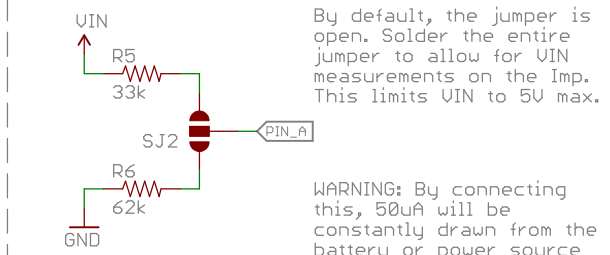

Input Voltage Measurement

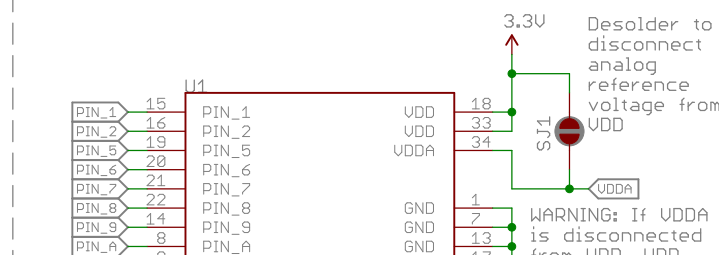

imp002 Module

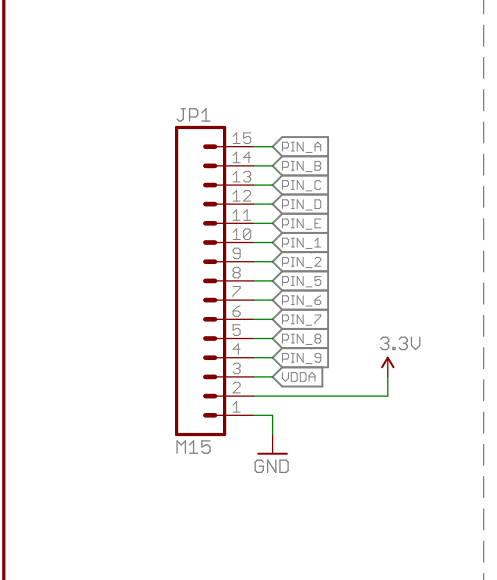

Pin Breakout

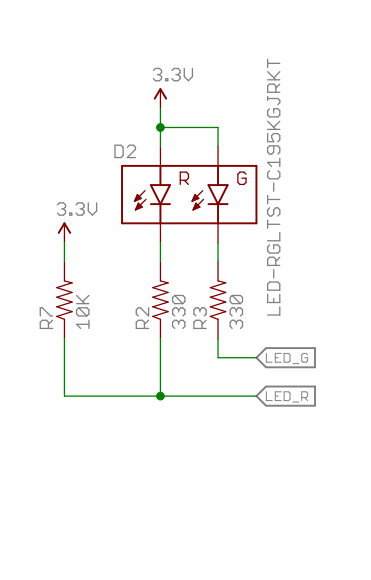

Status LEDs

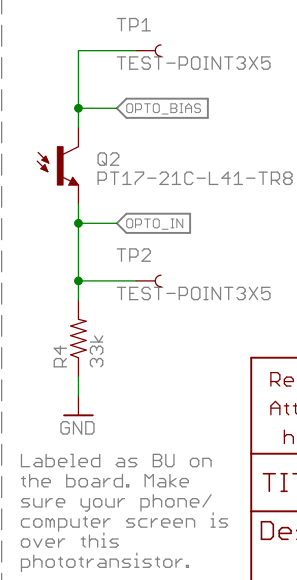

BlinkUp



Released under the Creative Commons Attribution Share-Alike 4.0 License
<https://creativecommons.org/licenses/by-sa/4.0/>

TITLE: Electric_Imp_imp002_Breakout SFE

Design by: Shawn Hymel (SparkFun Electronics) Based on Electric Imp's Amber board REV: v10

Date: 12/11/2014 5:16:29 PM Sheet: 1/1