

A touch screen is a 2-dimensional sensing device that is constructed of 2 sheets of material separated slightly by spacers. A common construction is a sheet of glass providing a stable bottom layer and a sheet of Polyethylene (PET) as a flexible top layer.

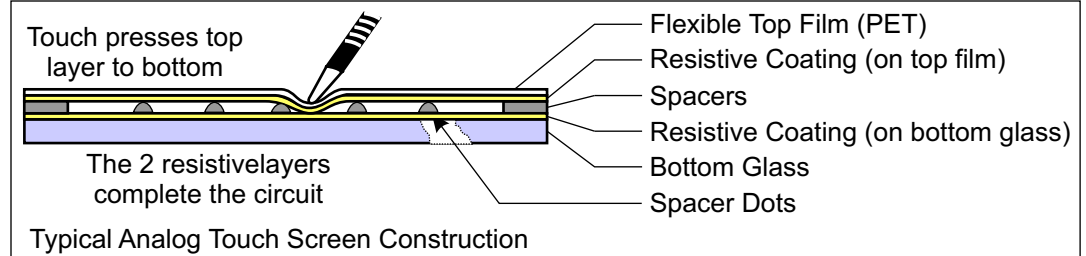

The 2 sheets are coated with a resistive substance, usually a metal compound called Indium Tin Oxide (ITO). The ITO is thin and uniformly sputtered onto both the glass and the PET layer. Tiny bumps called spacer dots are then added to the glass side, on top of the resistive ITO coating, to keep the PET film from sagging, causing an accidental or false touch.

When the PET film is pressed down, the two resistive surfaces meet. The position of this meeting (a touch) can be read by a touch screen controller circuit.

Layer Construction Detail

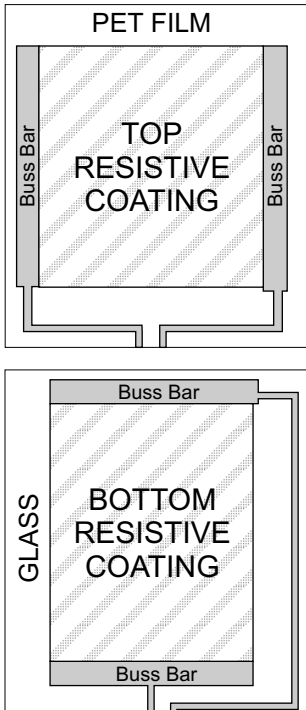

Capturing the "X" Touch

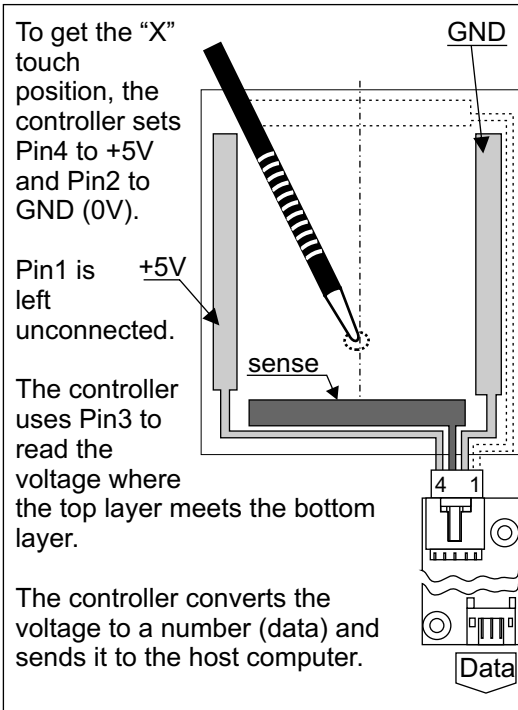

Capturing the "Y" Touch

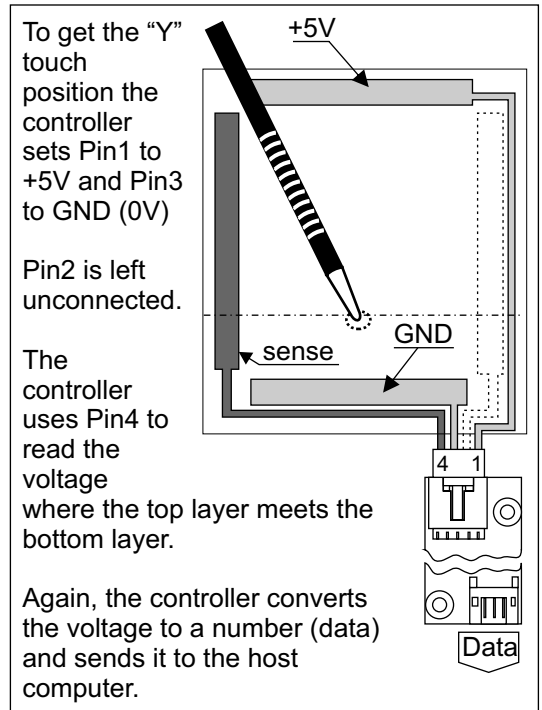

Circuit for X position sensing

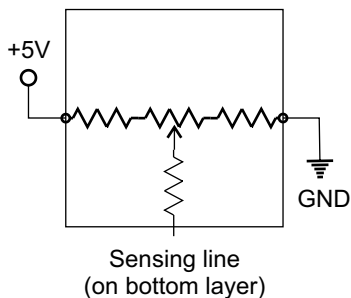

Circuit for Y position sensing

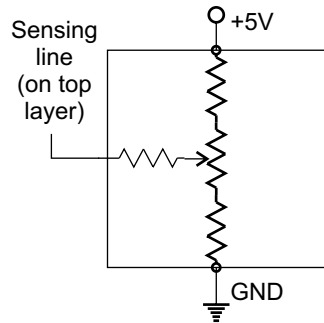

Notice that some pins switch functions depending on if the controller is looking for a X-touch or a Y-touch position

The controller reads the X and Y position many times per second so the user may move his stylus (or finger) rapidly across the touch screen and the data will be captured. This provides smooth operation and allows drag-and-drop or signature capture.

HantouchUSA driver software allows the user to decide which side is "up" on the touch screen; the software will adjust.

HantouchUSA controllers and driver software allow several levels of calibration to meet your sensitivity requirements.