



# PRODUCT SPECIFICATION

Ver: A

DATE: 2013-02-02

DOC No:  
ER-GSP585360-A-0001

For Any Detail and question, Please Tel Engineer: **86(0)756-6229769**, FAX: **86(0)756-5110999**

GREAT POWER BATTERY CO., LTD  
珠海鹏辉电池有限公司

Add: XINQING 5<sup>th</sup> RD, DOUMEN DISTRICT, ZHUHAI, GD, CHINA  
地址: 中国广东珠海斗门新青五路

CUSTOMER NO: W00099

## Specification Approval Sheet 规格确认书

**MODEL/型号: GSP585360\*3P**

(6000mAh 3.7V)

Prepared By/Date 编制/日期	Checked By/Date 审核/日期	Checked By/Date 审核/日期	Approved By/Date 批准/日期
黄光灿  2013-02-02			

	Singture/签字	Date/日期
Customer Approval 客户确认		
	Company Name/公司名称	
	Company Stamp/公司印章	



# PRODUCT SPECIFICATION

Ver:

A

DATE:

2013-02-02

DOC No:

ER-GSP585360-A-0001

For Any Detail and question, Please Tel Engineer: **86(0)756-6229769**, FAX: **86(0)756-5110999**

## Amendment Records/修正记录

Revision 版本	Description/记述	Prepared by 编制	Approved by 批准	Date/日期
A	First Publish	Paul		



# PRODUCT SPECIFICATION

Ver: A

DATE: 2013-02-02

DOC No:  
ER-GSP585360-A-0001

For Any Detail and question, Please Tel Engineer: **86(0)756-6229769**, FAX: **86(0)756-5110999**

## Content/目录

1. Scope/适用范围	Page 4
2. Model/型号	Page 4
3. Cell Specification/电芯规格说明	Page 4/5
4. Battery/Cell performance test Criteria/电池性能标准	Page 6
4.1 Appearance inspection by visual/外观目测	Page 6
4.2 Environmental test condition/外界环境条件	Page 6
4.3 Electrical characteristics/电气特性	Page 6
4.4 Mechanical characteristics/机械特性	Page 7
4.5 Safty performance/安全性能	Page 8
5. Cell initial Dimensions/电芯初始尺寸	Page 9
6. Battery specification/产品规格	Page 10
7. PCM specification /保护板参数	Page 11
8. Application Circuit/线路板原理图	Page 12
9. PCM BOM LIST/保护板元件清单	Page 13
10. Battery Pack Dimensions/电池组尺寸	Page 14
11. Handling of Cells /电池操作注意事项	Page 15
11.1 Consideration of strength of film package /外包装薄膜注意事项	Page 15
11.2 Prohibition short circuit/禁止电池短路	Page 15
11.3 Mechanical shock/机械撞击	Page 15
11.4 Handling of tabs/极耳操作注意事项	Page 15
12. Notice for Designing Battery Pack/电池外壳设计注意事项	Page 15
12.1 Pack toughness/外壳坚韧度	Page 15
12.2 Cell fixing/电池的固定	Page 15
12.3 Inside design/外壳内部设计	Page 15
12.4 Tab connection /极片连接	Page 15/16
12.5 For mishaps/针对意外事件	Page 16
13. Notice for Assembling Battery Pack 电池装配注意事项	Page 16
14. Others/其它	Page 16
14.1 Cell connection/电池连接	Page 16
14.2 Prevention of short circuit within a battery pack/电池内部的短路预防	Page 16
14.3 Prohibition of disassembly/禁止拆卸	Page 16/17
14.4 Prohibition of dumping of cells into fire/不要把电池倾倒在火中	Page 17
14.5 Prohibition of cells immersion into liquid such as water/禁止浸泡电池	Page 17
14.6 Battery cells replacement/更换电池	Page 17
14.7 Prohibition of use of damaged cells/禁止使用损坏的电	Page 17
15. Period of Warranty/保质期	Page 17
16. Storage of the Batteries/电池的存放	Page 17
17. Other The Chemical Reaction/其它化学反应	Page 17
18. Note/注释	Page 17



# PRODUCT SPECIFICATION

Ver: A

DATE: 2013-02-02

DOC No:  
ER-GSP585360-A-0001

For Any Detail and question, Please Tel Engineer: 86(0)756-6229769, FAX: 86(0)756-5110999

## 1 Scope/适用范围

This specification is applies to describe the related Battery product in this Specification and the Battery/cell supplied by Great Power Battery Co., Ltd only.

本说明书只适用于描述本规格书中相关的产品以及鹏辉电池有限公司提供的电池。

## 2 Model/型号: **GSP585360\*3P**

## 3 Cell Specification/电芯产品规格

No.	Items/项目	Specifications/规格		Remark 备注
1	Nominal Capacity 标称容量	2000mAh		0.2C Standard discharge 0.2C 标准放电
2	Minimum Capacity 最小容量	1950mAh		
3	Nominal Voltage 标称电压	3.7V		Mean Operation Voltage 即工作电压
4	Delivery voltage 交货电压	3.7~3.9V		Within 10 days from Factory 在出厂 10 天内
5	Charge Voltage 充电电压	4.2V±0.03V		By standard charge method 标准充电方式
6	Standard charging method 标准充电方式	0.5C constant current,4.2V constant voltage charge to 4.2V,continue charging till current deliene to ≤0.01C		0.5C 恒流 4.2V 恒压充至电流≤0.01C,时间 4.5h(供参考)
7	Charge current 充电电流	0.5C	1000mA	Standard charge, charge time:4.5h(Ref) 标准充电, 时间 4.5h(供参考)
		1.0C	2000mA	Rapid Charge, charge time:3.0h(Ref) 快速充电, 时间 3h(供参考)
8	Standard discharging method 标准放电方式	0.2C constant current discharge to 3.0V,		0.2C 恒流放电至 3.0V
9	Cell Internal Impedance 单电芯内阻	≤50mΩ		Internal resistance measured at AC 1KHz after 50% charge 半电态下用交流法测量内阻



# PRODUCT SPECIFICATION

Ver:

A

DATE:

2013-02-02

DOC No:

ER-GSP585360-A-0001

For Any Detail and question, Please Tel Engineer: 86(0)756-6229769, FAX: 86(0)756-5110999

## 3 Cell Specification/产品规格(continuous/续上表)

No.	Items/项目	Specifications/规格		Remark 备注
10	Maximum charge current 最大充电持续电流	1C	2000mA	For continuous charging mod 连续充电模式
11	Maximum discharge current 最大放电持续电流	1C	2000mA	For continuous discharge mod 连续放电模式
12	Operation Temperature and relative humidity Range 工作温度和湿度范围	Charge/充电	0~45°C 60±25%R.H.	Charge at a very low temperature such as blew 0°C, will be get a lower capacity and reduce cycle life of the battery 低温充电效率会下降, 会影响电池使用寿命
		Discharge/放电	-20~60°C 60±25%R.H.	
13	Storage temperature for a long time 长时间储存温度	-20~25°C 60±25%R.H.		Do not storage exceed half year. Must charge once when storage for half year. Must charge the battery which with protect circuit when storage for three mouths. 不可超过半年, 达到半年须充电一次 带保护板电池 3 个月充电一次



# PRODUCT SPECIFICATION

Ver: A

DATE: 2013-02-02

DOC No:  
ER-GSP585360-A-0001

For Any Detail and question, Please Tel Engineer: **86(0)756-6229769**, FAX: **86(0)756-5110999**

## 4 Battery/Cell performance test Criteria/电池性能标准

### 4.1 Appearance inspection by visual/外观目测

There shall be no such defect as flaw, crack, rust, leakage, which may adversely affect commercial value of battery.

电池外观应没有裂纹、爆裂、锈渍、污渍、漏液等影响商业价值的缺陷存在。

### 4.2 Environmental test condition/外界环境条件

Unless otherwise specified, all test stated in this product specification are conduct at below test condition

所有测试应按以下环境条件进行，除非特殊指定外。

Temperature: 20°C~25°C

Relative Humidity: 60%±25% R.H.

### 4.3 Cell Electrical characteristics/电气特性

No	Items/项目	Test Method and Condition/测试方法及条件	Criteria/标准
1	Rated Capacity at 0.2C(Min.) 0.2C 最小额定容量	After standard charge,the capacity shall be measured on 0.2C discharge till the voltage discharge to 3.0V, 标准充电后，放电至 3.0V 截止，测量 0.2C 放电容量	≥1950mAh ≥100%
	Rated Capacity at 0.5C(Min.) 0.5C 最小额定容量	After standard charge,the capacity shall be measured on 0.5C discharge till the voltage discharge to 3.0V, 标准充电后，放电至 3.0V 截止，测量 0.5C 放电容量	≥1911mAh ≥98%
	Rated Capacity at 1C(Min.) 1C 最小额定容量	After standard charge,the capacity shall be measured on 1C discharge till the voltage discharge to 3.0V, 标准充电后，放电至 3.0V 截止，测量 1C 放电容量	≥1852mAh ≥95%
2	Cycle Life 循环寿命	Charging and discharging battery as blew conditions 0.5C standard charge to 4.2V end-off 0.5C standard discharge to 3.0V cut-off Continuous charge and discharge for 500 cycles,the capacity will be measure after the 500 <sup>th</sup> cycle 充放电按以下条件： 0.5C 标准充电至 4.2V，0.5C 标准放电至 3.0V，连续充放电循环 500 周，在第 500 周结束后测量容量	≥70% of initial capacity
3	Capacity retention 容量保持	The battery to be charge in accordance whit standard charge condition at 20~25°C,then storage the battery at an ambient temperature 20~25°C for 28 days. Measure the capacity after 30 days with 0.2C at 20~25°C as retention capacity 将电池在 20~25°C 标准充电后储存在 20~25°C 的环境中 28 天 28 天后，测试电池在 20~25°C 环境下 0.2C 放电容量作为保持容量	Retention capacity 容量保持 ≥85%



# PRODUCT SPECIFICATION

Ver: A

DATE: 2013-02-02

DOC No:  
ER-GSP585360-A-0001

For Any Detail and question, Please Tel Engineer: **86(0)756-6229769**, FAX: **86(0)756-5110999**

## 4.4 Mechanical characteristics/机械特性

No	Items/项目	Test Method and Condition/测试方法及条件	Criteria/标准
1	Free fall test 自由跌落测试	The battery to be fully charged in accordance with standard charge condition, then drop the battery three times from a height of 1,0 m onto a concrete floor. The batteries are dropped so as to obtain impacts in random orientations. 电池按照标准充电条件充满电, 然后从1m高度跌落电池到一个水泥地面, 随机跌落三次。	No Fire, 不起火, 不爆炸
2	Vibration test 振动测试	After standard charging, fixed the cell to vibration table and subjected to vibration cycling that the frequency is to be varied at the rate of 1Hz per minute between 10Hz and 55Hz, the excursion of the vibration is 1.6mm. The cell shall be vibrated for 30 minutes per axis of XYZ axes. 将标准充电后的电芯固定在振动台上, 沿 X、Y、Z 三个方向各振动 30 分钟, 振幅 1.6mm, 振动频率为 10Hz~55Hz, 每分钟变化 1Hz。	No explosion, No leakage, No fire 无泄漏, 不起火, 不爆炸
3	Crush test 挤压测试	Fully charged the battery in accordance with standard charge condition, the battery is to be crushed between two flat plates. Continuous to applied force on battery of 13kN(17.2Mpa), stopped until a pressure reading of 17.2Mpa is reached on the hydraulic ram 电池按标准充电条件充满电, 放置在两块平面金属板间, 持续施加 13KN (17.2Mpa) 的压力, 直到液压油缸施加的压力达到 13KN (17.2Mpa) 时停止。	No explosion, No fire 无起火无爆炸
4	Shock test 撞击测试	The fully charged battery is secured to the testing machine by means of a rigid mount which will support all mounting surfaces of the cell or battery. The battery is subjected to a total of three shocks of equal magnitude. The shocks are applied in each of three mutually perpendicular directions. At least one of them shall be perpendicular to a flat face. For each shock the cell or battery is accelerated in such a manner that during the initial 3 milliseconds the minimum average acceleration is 75 gn. The peak acceleration shall be between 125 gn and 175 gn. Cells or batteries are tested in an ambient temperature of 20~25°C	No explosion, No leakage, No fire 无泄漏, 不起火, 不爆炸



# PRODUCT SPECIFICATION

Ver: A

DATE: 2013-02-02

DOC No:  
ER-GSP585360-A-0001

For Any Detail and question, Please Tel Engineer: 86(0)756-6229769, FAX: 86(0)756-5110999

## 4.5 Safty performance/安全性能

No	Items/项目	Test Method and Condition/测试方法及条件	Criteria/标准
1	Thermal exposure test 高温热冲击测试	Each fully charged cell, stabilized at room temperature, is placed in a circulating air-convection oven. The oven temperature is raised at a rate of 5 °C/min ± 2 °C/min to a temperature of 130 °C ± 2 °C. The cell remains at this temperature for 10 min before the test is discontinued. 充满电的电池温度稳定到常温后, 放置入循环空气烘箱里, 从常温以5 °C/分± 2 °C/分的速率升至130°C后, 在130°C放置10分钟	No explosion, No fire 无起火, 无爆炸
2	Low pressure 低压测试	Each fully charged cell is placed in a vacuum chamber, in an ambient temperature of 20~25°C. Once the chamber has been sealed, its internal pressure is gradually reduced to a pressure equal to or less than 11,6 kPa (this simulates an altitude of 15240 m) held at that value for 6 h. 电池放在一个模拟真空的空间放置6小时, 环境温度为20~25°C., 真空环境压力≤11.6kpa, 模拟15240m高空低压环境	No explosion, No leakage, No fire 无泄漏, 不起火, 不爆炸
3.	Short test 短路测试	The fully charged battery is to be short-circuited by connecting the positive and negative terminals of the battery with resistance load not exceed 100m Ω. Tests are to be conducted at room temperature 20~25°C. 在室温 20~25°C把充满电的电池的正负极用不超过100mΩ的负载连接起来, 连接起来使电池外部短路	No explosion, No fire The Temperature of the Battery surface not exceeded than 150°C 无起火, 无爆炸 电池表面温度不超过 150°C
4	Forced discharge test 过放电测试	A discharged cell is subjected to a reverse charge at 1C for 90 min. 将电芯放完电, 再用 1C 反接充电 90 分钟	No explosion, No fire 无起火, 无爆炸
5	Over charge test 过充电测试	After standard charge, continue to charge with a constant voltage 4.6V per a cell, holding 8h. 电芯标准充满电后, 以 4.6V 的恒定电压继续充电, 保持 8 小时	No explosion, No fire, No leakage 无爆炸, 无起火, 无漏液
6	Soak Test 浸泡测试	Put the batteries into clean water, be soaked for 24 hours. 把电池放进清水中浸泡 24 个小时	No break, No fire 无破裂, 无起火



For Any Detail and question, Please Tel Engineer: **86(0)756-6229769**, FAX: **86(0)756-5110999**

## 5 Cell initial Dimensions/电芯初始尺寸

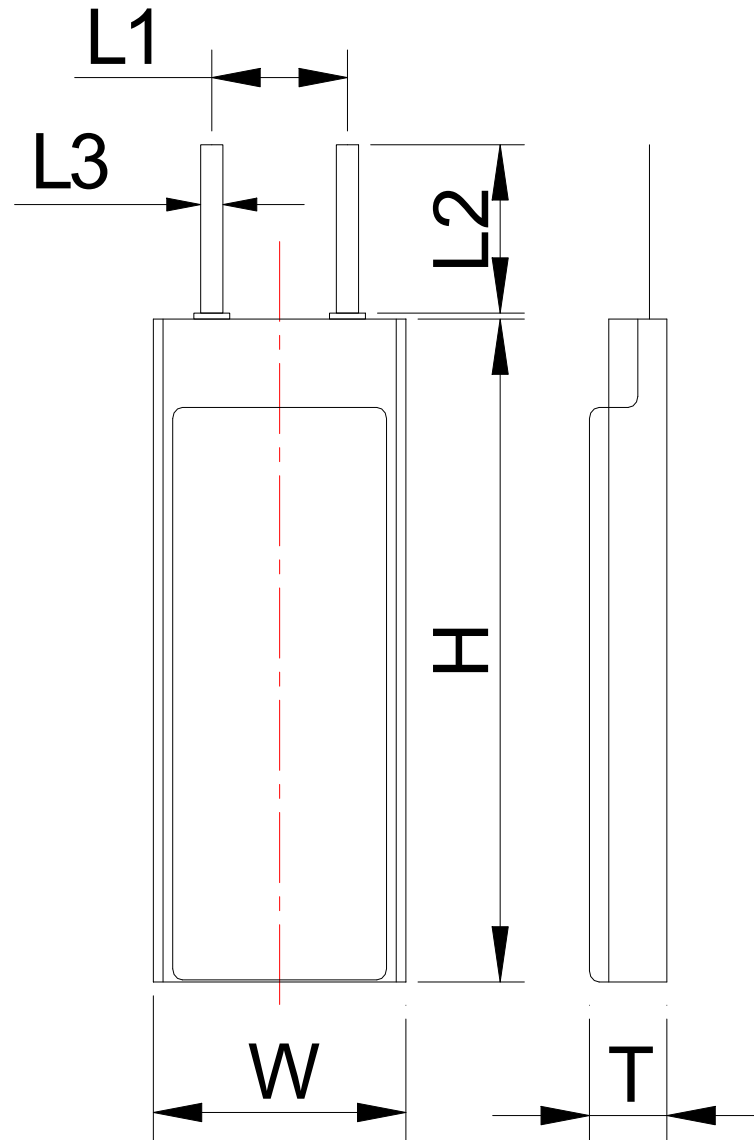

NO	Items	Units: mm	Remark
1	Thickness/厚度	6.0	Max.
2	Width/宽度	53.3	Max.
3	Height/长度	60.5	Max.
4	L1	36±2	
5	L2	10±2	
6	L3	4±0.1	

Drawed/制图	Checked/审核	Approved/批准
<b>Paul</b>		



# PRODUCT SPECIFICATION

Ver:

A

DATE:

2013-02-02

DOC No:

ER-GSP585360-A-0001

For Any Detail and question, Please Tel Engineer: **86(0)756-6229769**, FAX: **86(0)756-5110999**

## 6 Battery specifications/产品规格

No.	Items/项目	Specifications/规格	Remark 备注
1	Capacity for assembled cell discharging by 0.2C 电芯组装后 0.2C 标准放电方式的容量	$\geq 5850\text{mAh}$	Standard discharging method 标准放电方式
2	Battery Voltage 电池电压	3.7V~3.9V	Delivery voltage, Within 10 days from Factory 交货电压, 在出厂 10 天内
3	Standard charge condition 标准充电条件	Charge with 0.5C constant current and 4.2V constant voltage, charge to 4.2V, continue charging till current decline to $\leq 0.01\text{C}$ 充电电流用 0.5C 恒流, 4.2V 恒压充至电流 $\leq 0.01\text{C}$	Charge voltage: $4.2\text{V} \pm 0.02\text{V}$ Charge current: 0.5C 充电电压: $4.2\text{V} \pm 0.02\text{V}$ 充电电流: 0.5C
4	Standard discharging method 标准放电方式	0.2C constant current discharge to 3.0V,	0.2C 恒流放电至 3.0V
5	Assemblage Maximum charge current 组装后最大充电持续电流	6000mA	For continuous charging mod 连续充电模式
6	Assemblage Maximum discharge current 组装后最大放电持续电流	6000mA	For continuous discharge mod 连续放电模式
5	Internal Impedance 内阻	Assemblage Impedance 装配后内阻 $\leq 200\text{m}\Omega$	Measure two sides of the drawing line after assembling. 装配后测试电池引线两端



# PRODUCT SPECIFICATION

Ver:	A
DATE:	2013-02-02
DOC No: ER-GSP585360-A-0001	

For Any Detail and question, Please Tel Engineer: 86(0)756-6229769, FAX: 86(0)756-5110999

## 7 PCM specification/保护板参数

保护 IC	R5402N149KD	技术参数 parameter value			
项目名称 Item name	最小值 min	典型值 type	最大值 max	单位 unit	
过充保护电压 Over-charge Threshold Voltage	4.255	4.280	4.305	V	
过充保护恢复电压 Released voltage from Over-charge	4.030	4.080	4.130	V	
过放保护电压 Over-discharge Threshold	2.827	2.900	2.973	V	
过放保护恢复电压 Released Voltage from Over-discharge	3.022	3.100	3.178	V	
放电过流检测电压 Excess discharge-current threshold	0.110	0.125	0.140	V	
放电过流保护电流 excess discharge-current detect current	3.000	4.500	6.000	A	
过充电检测延迟时间 Output Delay of Over-charge	0.7	1.0	1.3	s	
过放电检测延迟时间 Output Delay of Over-discharge	14	20	26	ms	
过电流检测延迟时间 Output delay of excess discharge-current	8	12	16	ms	
短路保护延迟时间 Delay Time for Short Protection	230	300	500	μs	
正常状态下静态电流 Supply Current	-	4.0	8.0	μA	
过放状态下静态电流 Standby Current	-	1.2	2.0	μA	
导通内阻 Impedance Resistance of operation	-	-	70	mΩ	
输入电压 (B+与B-间) Supply Voltage	-0.3	-	+12	V	
工作温度 Operating Temperature	-40	-	85	℃	
推荐贮存条件 Storage Temperature	-	25	-	℃	
0V 电池充电功能 for 0V Charging	-	可能	-		

Ver:	A
DATE:	2013-02-02
DOC No: ER-GSP585360-A-0001	

For Any Detail and question, Please Tel Engineer: **86(0)756-6229769**, FAX: **86(0)756-5110999**

## 8 8.1 Application Circuit 线路板原理图

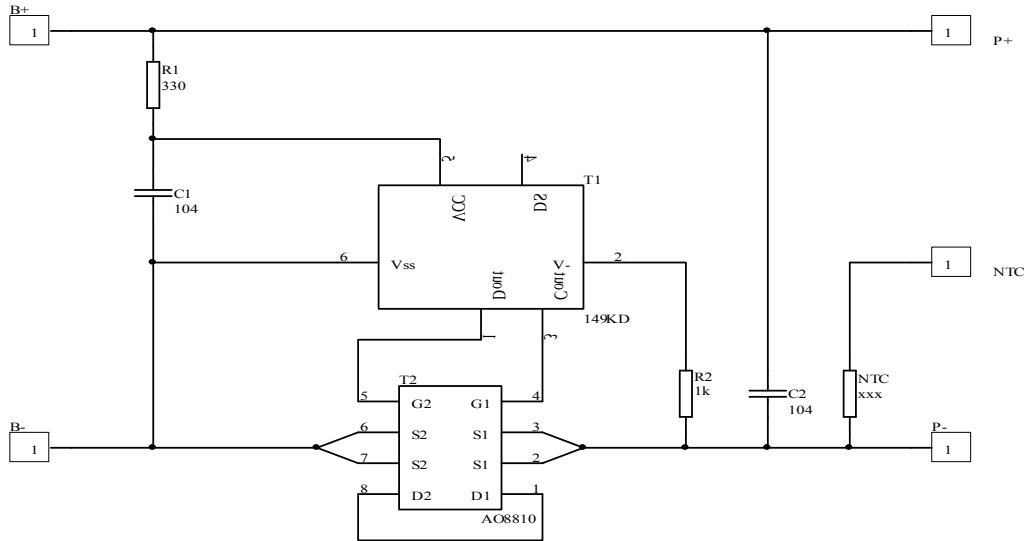

## 8.2 PCB 图 PCB layout

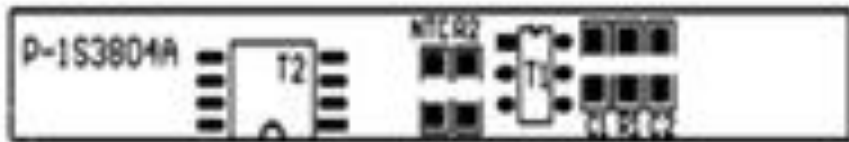



# PRODUCT SPECIFICATION

Ver:

A

DATE:

2013-02-02

DOC No:

ER-GSP585360-A-0001

For Any Detail and question, Please Tel Engineer: **86(0)756-6229769**, FAX: **86(0)756-5110999**

## 9 PCM BOM LIST/保护板元件清单

序号 No.	物料名称 description	供应商 vendor	代号 symbol	规格/型号 Spec./model	单位 unit	数量 Pcs
1	线路板	JHY	PCB	P-13804A (38*4-0.8)	pcs	1
2	电阻	YAGEO	R1	330/0603	pcs	1
3	电阻	YAGEO	R2	1K/0603	pcs	1
4	电容	YAGEO	C1/C2	104/0603	pcs	2
5	IC	RICHO	T1	R5402N149KD /SOT23-6	pcs	1
6	MOS	华茂粤	T2	AO8810/TSSOP-8	pcs	1

For Any Detail and question, Please Tel Engineer: 86(0)756-6229769, FAX: 86(0)756-5110999

## 10 Battery Pack Dimensions/电池组尺寸

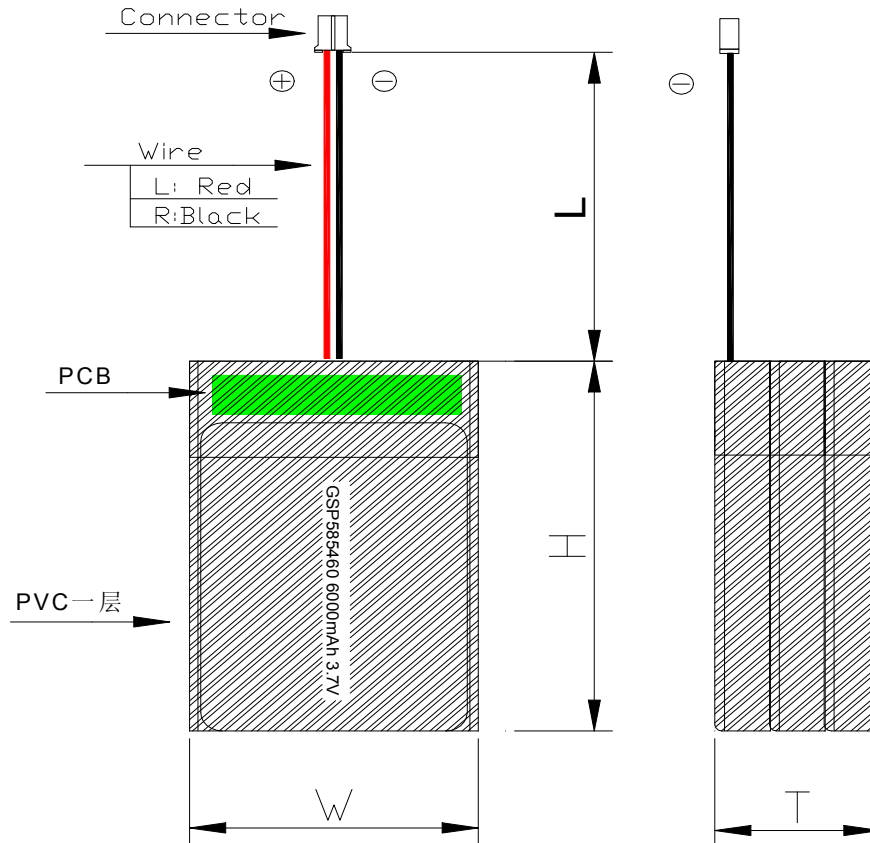

NO	Items	Units:mm		Remark
1	Thickness/厚度	T	19.5	Max.
2	Width/宽度	W	55.0	Max.
3	Height/长度	H	62.5	Max.
4	Cable Length/引线长度	L	100±5	
5	Lead strip line length/引线剥线长	L1	2~3	

### BOM of Battery Pack/电池组物料清单

NO	Part name/名称	Quantity/数量	Unit/单位	Remark
1	Cell/电芯	1	ea	Great Power
2	Tape/胶带	~250~	mm	
3	Solder/焊锡	0.2	g	Lead Free
4	Connector/插头	1	Pcs	JST-PH-2P 反 1007/24#
5	PCB/连接板	1	pcs	P-1S3804AB<149KD+8810>



# PRODUCT SPECIFICATION

Ver:

A

DATE:

2013-02-02

DOC No:

ER-GSP585360-A-0001

For Any Detail and question, Please Tel Engineer: **86(0)756-6229769**, FAX: **86(0)756-5110999**

## 11 Handling of Cells / 电池操作注意事项

### 11.1 Consideration of strength of film package / 包装薄膜注意事项

#### 1) Soft Aluminium foil/ 铝箔软包装

Easily damaged by sharp edge parts such as pins and needles, Ni-tabs, so don't strike by those sharp parts.

铝箔软包装比较容易被锐利部件刺损，如针尖、镍带，所以不要用这此锐利的部件刻划电池。

#### 2) Sealed edge may be damaged by heat above 100°C, bend or fold sealed edge.

封边被加热到 100°C 以上以及弯折封边都容易使封边受损。

### 11.2 Prohibition short circuit/ 禁止电池短路

Never make short circuit cell. It generates very high current which causes heating of the cells and may cause electrolyte leakage, gassing or explosion that are very dangerous.

The LIP tabs may be easily short-circuited by putting them on conductive surface.

Such outer short circuit may lead to heat generation and damage of the cell.

An appropriate circuitry with PCM shall be employed to protect accidental short circuit of the battery pack.

避免电池短路。短路会产生很高的电流而使电池发热以及电解液泄漏，产生有毒气体或爆炸是非常危险的。极片连接在导电物体表面很容易短路，外部短路会导致发热及损害电池。选用一个适当的保护电路可以在意外短路时保护电池。

### 11.3. Mechanical shock/ 机械撞击

LIP cells have less mechanical endurance than metal-can-cased LIB.

Falling, hitting, bending, etc. may cause degradation of LIP characteristics.

聚合物电池比金属外壳电池的机械耐久性更小。

跌落、碰撞、弯曲等等都可能会降低聚合物电池的性能。

### 11.4 Handling of tabs/ 极耳操作注意事项

The battery tabs are not so stubborn especially for aluminum tab.

Don't bend tab.

Do not bend tabs unnecessarily.

极耳的机械强度并非异常坚固，特别是铝片。没有必要时禁止弯折极片。

## 12 Notice for Designing Battery Pack/ 电池外壳设计注意事项

### 12.1 Pack toughness/ 外壳坚韧度

Battery pack should have sufficient strength and the LIP cell inside should be protected from mechanical shocks.

电池外壳应该有足够的机械强度使聚合物电池免受机械撞击。

### 12.2 Cell fixing/ 电池的固定

The LIP cell should be fixed to the battery pack by its large surface area.

No cell movement in the battery pack should be allowed.

电池最大面积的一面应该固定在外壳上，安装后电池不能有松动。

### 12.3 Inside design/ 外壳内部设计

No sharp edge components should be insides the pack containing the LIP cell.

外壳内安装电池的部位不应有锋锐边。

### 12.4 Tab connection / 极片连接

Ultrasonic welding or spot welding is recommended for LIP tab connection method.

Battery pack should be designed that shear force are not applied to the LIP tabs.

If apply manual solder method to connect tab with PCM, below notice is very important to ensure battery performance:

1) The solder iron should be temperature controlled and ESD safe;

2) Soldering temperature should not exceed 350°C;

3) Soldering time should not be longer than 3s;



# PRODUCT SPECIFICATION

Ver: A

DATE: 2013-02-02

DOC No:  
ER-GSP585360-A-0001

For Any Detail and question, Please Tel Engineer: **86(0)756-6229769**, FAX: **86(0)756-5110999**

4) Soldering times should not exceed 5 times, Keep battery tab cold down before next time soldering;

5) Directly heat cell body is strictly prohibited, Battery may be damaged by heat above approx. 100°C

建议使用超声波或点焊焊接方法；外壳设计应使极片不受外力。

如果使用人工焊接保护板，下面的注意事项对于确保电池性能非常重要：

- 1) 焊接铬铁的温度必须可控且可防静电；
- 2) 焊接时铬铁的温度不能超过 350°C；
- 3) 焊锡时间不能超过 3 秒钟；
- 4) 焊锡次数不能超过 5 次，待极片冷却后才能进行下一次焊锡；
- 5) 严禁直接加热电芯，高于 100°C 度会损害电芯。

## 12.5 For mishaps/针对意外事件

Battery pack should be designed not to generate heat even when leakage occurs due to mishaps.

- 1) Isolate PCM (Protection Circuit Module) from leaked electrolyte as perfectly as possible.
- 2) Avoid narrow spacing between bare circuit patterns with different voltage.

(Including around connector)

LIP battery should not have liquid from electrolyte, but in case If leaked electrolyte touch bare circuit patterns, higher potential terminal material may dissolve and precipitate at the lower potential terminal, and may cause short circuit. The design of the PCM must have this covered.

发生意外时外壳设计应考虑即使在电池出现漏液时也不会发热。

- 1) 尽量把保护电路与渗漏的电解液隔离开。
- 2) 在不同的电压情况下避免出现小间距的裸露电路——包括插头周围。
- 3) 聚合物电池不应该有来自电解液的液体，但是一旦发生电解液渗漏触及裸露电路，高电势端子材料可能会溶解然后沉淀到低电势端子，可能会造成短路。保护板的设计必须含有覆盖保护层。

## 13 Notice for Assembling Battery Pack 电池装配注意事项

Shocks, high temperature, or contacts of sharp edge components should not be allowed in battery pack assembling process.

在电池装配过程中不允许撞击、高温或接触尖锐部分。

## 14 Others/其它

### 14.1 Cell connection/电池连接

- 1) Direct soldering of wire leads or devices to the cell is strictly prohibited.
- 2) Lead tabs with pre-soldered wiring shall be spot welded to the cells.

Direct soldering may cause damage of components, such as separator and insulator, by heat generation.

- 1) 严禁直接焊接引线或设备到电池上。
- 2) 极片在焊接引线之前应该先点焊到电池上，直接与电池热焊接，产生的热量会使电池的隔离体及绝缘体受损。

### 14.2 Prevention of short circuit within a battery pack/电池内部的短路预防

Enough insulation layers between wiring and the cells shall be used to maintain extra safety protection. The battery pack shall be structured with no short circuit within the battery pack, which may cause generation of smoke or firing.

在电池和引线之间应该有足够的绝缘层用于安全保护。电池的包装构成应没有导致起烟起火的短路情况。

### 14.3 Prohibition of disassembly/禁止拆卸

- 1) Never disassemble the cells

The disassembling may generate internal short circuit in the cell, which may cause gassing, firing, explosion, or other problems.

- 2) Electrolyte is harmful

LIP battery should not have liquid from electrolyte flowing, but in case the electrolyte come into contact with the skin, or eyes, physicians shall flush the electrolyte immediately with fresh water and medical advice is to be sought.





# PRODUCT SPECIFICATION

Ver:

A

DATE:

2013-02-02

DOC No:

ER-GSP585360-A-0001

For Any Detail and question, Please Tel Engineer: **86(0)756-6229769**, FAX: **86(0)756-5110999**

1) 不要拆卸电池。

拆卸电池会发生电池内部短路，会引起起火、爆炸、有害气体或者其它问题。

2) 电解液是有害的

万一电解液沾到皮肤、进入眼睛，应立即用清水冲洗以及求助医生。

#### 14.4 Prohibition of dumping of cells into fire/不要把电池倾倒在火中

Never incinerate nor dispose the cells in fire. These may cause explosion of the cells, which is very dangerous and is prohibited.

不要焚毁电池，否则会致电池爆炸，这个很危险，必须禁止。

#### 14.5 Prohibition of cells immersion into liquid such as water/禁止浸泡电池

The cells shall never be soaked with liquids such as water, seawater, drinks such as soft drinks, juices, coffee or others.

请不要把电池浸泡在液体当中，像清水、海水，及非酒精饮料、果汁、咖啡或者其它的饮料。

#### 14.6 Battery cells replacement/更换电池

The battery replacement shall be done only by either cells supplier or device supplier and never be done by the user.

更换电池应由电池生产商或设备供应商完成，用户不要自行更换。

#### 14.7 Prohibition of use of damaged cells/禁止使用损坏的电池

The cells might be damaged during shipping by shock. If any abnormal features of the cells are found such as damages in a plastic envelop of the cell, deformation of the cell package, smelling of an electrolyte, an electrolyte leakage and others, the cells shall never be used any more.

The Cells with a smell of the electrolyte or a leakage shall be placed away from fire to avoid firing or explosion.

电池可能在出货途中碰撞而受损。如果发现电池有异常，例如包装损坏、电池包裹变形，有电解液的味道、发现漏液等等，不要再使用这些电池。

电池如果有电解液的味道或者出现漏液，电池放置应该远离火源避免起火及爆炸。

### 15 Period of Warranty/保质期

The period of warranty is half a year from the date of shipment. Great Power guarantees to give a replacement in case of cells with defects proven due to manufacturing process instead of the customer abuse and misuse.

电池的保质期从出货之日算起为半年。如果电池的缺陷是在制造过程中形成的而不是由于用户滥用及错误使用造成，本公司负责退换电池。

### 16 Storage of the Batteries/电池的存放

The batteries should be stored at room temperature, charged to about 30% to 50% of capacity.

We recommend that batteries be charged about once per half a year to prevent over discharge.

电池应当在室温下存放，应充到 30%至 50%的电量。如长时间储存，建议每半年充一次电以防止电池过放电。

### 17 Other The Chemical Reaction/其它化学反应

Because batteries utilize a chemical reaction, battery performance will deteriorate over time even if stored for a long period of time without being used. In addition, if the various usage conditions such as charge, discharge, ambient temperature, etc. are not maintained within the specified ranges the life expectancy of the battery may be shortened or the device in which the battery is used may be damaged by electrolyte leakage. If the batteries cannot maintain a charge for long periods of time, even when they are charged correctly, this may indicate it is time to change the battery.

由于电池是利用化学反应的原理，所以随着时间的增加电池的性能会降低，即使是存放很长一段时间而不使用。如果使用条件如充电、放电及周围环境温度等情形不在指定的使用范围内，会使缩短电池的使用寿命，或者会产生漏液导致设备损坏。如果电池长周期不能充电，即使充电方法正确，这样需要更换电池了。

### 18 Note/注释

Any other items which are not covered in this specification shall be agreed by both parties.

本说明书未包括事项应由双方协议确定。